



46 Discovery, Suite 250
Irvine, CA 92618
Tel: 949-474-1400
Fax: 946-261-8482

**ARMSTRONG RANCH
SPECIFIC PLAN
TRAFFIC IMPACT ANALYSIS
ONTARIO, CA**

July 2016

Prepared for:

**Phil Martin & Associates
4860 Irvine Boulevard, Suite 203
Irvine, CA 92620**

Prepared By:

**Keith R. Rutherford, TE
Josh D. Park, EIT
Kelly N. Tran**



Keith R. Rutherford

TABLE OF CONTENTS

	<u>PAGE</u>
I. INTRODUCTION AND EXECUTIVE SUMMARY	1
II. EXISTING STUDY AREA CONDITIONS	6
A. PROJECT STUDY AREA	6
A.1 Existing Traffic Volumes.....	7
A.2 Project Implementation Year Baseline Volumes.....	7
A.3 Existing and Project Implementation Year Baseline Level of Service (LOS) Analysis	8
A.4 Existing 2015 Traffic Conditions.....	30
A.5 Phase 1 Baseline 2017 Traffic Conditions.....	30
A.6 Phase 2 Baseline 2019 Traffic Conditions.....	31
A.7 Phase 3 Baseline 2021 Traffic Conditions.....	31
A.8 SR-60 Freeway Mainline Analysis with Existing Peak Hour Values.....	32
III. PROJECTED FUTURE TRAFFIC	34
A. TRIP GENERATION	34
A.1 Project Phase 3 Build-out (completion 2021) without Elementary School	34
A.2 Project Phase 3 Build-out (completion 2021) with Elementary School	34
A.3 Project Trip Distribution_	35
B. PROJECT TRAFFIC VOLUME FORECASTS	35
B.1 Phase 1 (2017) Project Traffic Volume Forecasts.....	35
B.2 Phase 2 (2019) Project Traffic Volume Forecasts.....	35
B.3 Phase 3 (2021) Project Traffic Volume Forecasts (without Elementary School)	36
B.4 Phase 3 (2021) Project Traffic Volume Forecasts (with Elementary School)	36
C. BASELINE WITH PROJECT TRAFFIC VOLUME FORECASTS.....	59
C.1 Phase 1 (2017) Baseline with Project Traffic Volumes	59
C.2 Phase 2 (2019) Baseline with Project Traffic Volumes	59

TABLE OF CONTENTS (Cont.)

	<u>PAGE</u>
C.3 Phase 3 (2021) Baseline with Project Traffic Volumes (without elementary school)	59
C.4 Phase 3 (2021) Baseline with Project Traffic Volumes (with elementary school)	60
C.5 SR60 Freeway Mainline Analysis with Phase 3	60
IV. TRAFFIC ANALYSIS	82
A.1 Project Phase 1 Baseline (2017) with Project Traffic Conditions	82
A.2 Project Phase 2 Baseline (2019) with Project Traffic Conditions	83
A.3 Project Phase 3 Baseline (2021) with Project (without school) Traffic Conditions	84
A.4 Project Phase 3 Baseline (2021) with Project (with school) Traffic Conditions	85
A.5 Project Phase 3 (2021) without Elementary School On-site Traffic Conditions.....	85
A.6 Project Phase 3 (2021) with Elementary School On-site Traffic Conditions.....	86
A.7 SR-60 Freeway Mainline Analysis for Phase 3 with Project Conditions	87
V. FINDINGS AND RECOMMENDATIONS	93
A. ROADWAY AND INTERSECTION INFRASTRUCTURE IMPLEMENTATION PLAN	93
A.1 Off-site Intersection and Roadway Analysis and Mitigation Recommendations.....	93
A.2 SR-60 Freeway Mainline Analysis.....	94

APPENDICES

APPENDIX A – Existing Peak Hour Intersection Turning Movements Counts and Roadway Link ADT's

APPENDIX B – Level of Service Computation Reports (HCM Calculations)

APPENDIX C –Traffic Signal Warrant Analysis

APPENDIX D – Freeway Mainline Analysis

APPENDIX E – San Bernardino Association of Governments (SANBAG) SBTAM Model Output

List of Figures

	<u>PAGE</u>
Figure 1	Project Location and Vicinity Map 3
Figure 2	Proposed Armstrong Ranch Site Plan 4
Figure 3	Traffic Study Project Phasing Plan 5
Figure 4	Project Study Area and Existing Intersection Geometrics and Controls 10
Figure 5A	Existing (2015) AM Peak Hour Study Area Traffic Volumes..... 11
Figure 5B	Existing (2015) PM Peak Hour Study Area Traffic Volumes 12
Figure 6	Existing (2015) Weekday 24-Hr Volumes and Volume to Capacity Ratios..... 13
Figure 7	Location of other Development Projects 14
Figure 8A	Phase 1 Baseline 2017 AM Peak Hour Study Area Traffic Volumes 15
Figure 8B	Phase 1 Baseline 2017 PM Peak Hour Study Area Traffic Volumes..... 16
Figure 9	Phase 1 Baseline 2017 Weekday 24-Hr Volumes and Volume to Capacity Ratios..... 17
Figure 10A	Phase 2 Baseline 2019 AM Peak Hour Study Area Traffic Volumes 18
Figure 10B	Phase 2 Baseline 2019 PM Peak Hour Study Area Traffic Volumes..... 19
Figure 11	Phase 2 Baseline 2019 Weekday 24-Hr Volumes and Volume to Capacity Ratios..... 20
Figure 12A	Phase 3 Baseline 2021 AM Peak Hour Study Area Traffic Volumes 21

July 2016

List of Figures (cont.)

	<u>PAGE</u>
Figure 12B	Phase 3 Baseline 2021 PM Peak Hour Study Area Traffic Volumes 22
Figure 13	Phase 3 Baseline 2021 Weekday 24-Hr Volumes and Volume to Capacity Ratios 23
Figure 14	SR-60 Freeway Mainline Analysis with Existing Peak Hour Volumes 33
Figure 15	SANBAG Project Trip Distribution – SBTAM Model 38
Figure 16A	Phase 1 (2017) Project AM Peak Hour Study Area Traffic Volumes 39
Figure 16B	Phase 1 (2017) Project PM Peak Hour Study Area Traffic Volumes 40
Figure 17	Phase 1 (2017) Project Weekday Daily Study Area Traffic Volumes 41
Figure 18A	Phase 1 (2017) Project AM Peak Hour Access and On-site Intersection Volumes 42
Figure 18B	Phase 1 (2017) Project PM Peak Hour Access and On-site Intersection Volumes 43
Figure 19A	Phase 2 (2019) Project AM Peak Hour Study Area Traffic Volumes 44
Figure 19B	Phase 2 (2019) Project PM Peak Hour Study Area Traffic Volumes 45
Figure 20	Phase 2 (2019) Project Weekday Daily Study Area Traffic Volumes 46
Figure 21A	Phase 2 (2019) Project AM Peak Hour Access and On-site Intersection Volumes 47
Figure 21B	Phase 2 (2019) Project PM Peak Hour Access and On-site Intersection Volumes 48
Figure 22A	Phase 3 (2021) Project AM Peak Hour Study Area Traffic Volumes 49

List of Figures (cont.)

	<u>PAGE</u>
Figure 22B	Phase 3 (2021) Project PM Peak Hour Study Area Traffic Volumes 50
Figure 23	Phase 3 (2021) Project Weekday Daily Study Area Traffic Volumes 51
Figure 24A	Phase 3 (2021) Project AM Peak Hour Access and On-site Intersection Volumes 52
Figure 24B	Phase 3 (2021) Project PM Peak Hour Access and On-site Intersection Volumes 53
Figure 25A	Phase 3 (2021) with School Project AM Peak Hour Study Area Traffic Volumes 54
Figure 25B	Phase 3 (2021) with School Project PM Peak Hour Study Area Traffic Volumes 55
Figure 26	Phase 3 (2021) with School Project Weekday Daily Study Area Traffic Volumes 56
Figure 27A	Phase 3 (2021) with School Project AM Peak Hour Access and On-site Intersection Volumes 57
Figure 27B	Phase 3 (2021) with School Project PM Peak Hour Access and On-site Intersection Volumes 58
Figure 28A	Phase 1 Baseline 2017 with Project AM Peak Hour Study Area Traffic Volumes 61
Figure 28B	Phase 1 Baseline 2017 with Project PM Peak Hour Study Area Traffic Volumes 62
Figure 29	Phase 1 Baseline 2017 with Project Weekday Daily Study Area Traffic Volumes 63

List of Figures (cont.)

	<u>PAGE</u>
Figure 30A Phase 1 Baseline 2017 with Project AM Peak Hour Access and On-site Intersection Volumes	64
Figure 30B Phase 1 Baseline 2017 with Project PM Peak Hour Access and On-site Intersection Volumes	65
Figure 31A Phase 2 Baseline 2019 with Project AM Peak Hour Study Area Traffic Volumes	66
Figure 31B Phase 2 Baseline 2019 with Project PM Peak Hour Study Area Traffic Volumes	67
Figure 32 Phase 2 Baseline 2019 with Project Weekday Daily Study Area Traffic Volumes	68
Figure 33A Phase 2 Baseline 2019 with Project AM Peak Hour Access and On-site Intersection Volumes	69
Figure 33B Phase 2 Baseline 2019 with Project PM Peak Hour Access and On-site Intersection Volumes	70
Figure 34A Phase 3 Baseline 2021 with Project AM Peak Hour Study Area Traffic Volumes	71
Figure 34B Phase 3 Baseline 2021 with Project PM Peak Hour Study Area Traffic Volumes	72
Figure 35 Phase 3 Baseline 2021 with Project Weekday Daily Study Area Traffic Volumes	73
Figure 36A Phase 3 Baseline 2021 with Project AM Peak Hour Access and On-site Intersection Volumes	74

List of Figures (cont.)

	<u>PAGE</u>
Figure 36B Phase 3 Baseline 2021 with Project PM Peak Hour Access and On-site Intersection Volumes	75
Figure 37A Phase 3 Baseline 2021 with Project (with School) AM Peak Hour Study Area Traffic Volumes	76
Figure 37B Phase 3 Baseline 2021 with Project (with School) PM Peak Hour Study Area Traffic Volumes	77
Figure 38 Phase 3 Baseline 2021 with Project (with School) Weekday Daily Study Area Traffic Volumes	78
Figure 39A Phase 3 Baseline 2021 with Project (with School) AM Peak Hour Access and On-site Intersection Volumes	79
Figure 39B Phase 3 Baseline 2021 with Project (with School) PM Peak Hour Access and On-site Intersection Volumes	80
Figure 40 SR-60 Freeway Mainline Analysis for Phase 3 Baseline 2021 with Project Conditions (with elementary school).....	81
Figure 41A Proposed Arterial Roadway Sections	95
Figure 41B Proposed Collector and Local Roadway Sections.....	96

List of Tables

	<u>PAGE</u>
Table 1A	Table 1A - Level of Service Descriptions (HCM – signalized) 24
Table 1B	Level of Service Descriptions (HCM - Unsignalized) 25
Table 2	Existing (2015) Level of Service at Study Area Intersections 26
Table 3	Phase 1 Baseline 2017 Level of Service at Study Area Intersections 27
Table 4	Phase 2 Baseline 2019 Level of Service at Study Area Intersections 28
Table 5	Phase 3 Baseline 2021 Level of Service at Study Area Intersections 29
Table 6	Armstrong Ranch Trip Generation 37
Table A.5-1	Project Phase 3 (2021) On-site Build-out Intersection Conditions (without Elementary School) 86
Table A.6-1	Project Phase 3 (2021) On-site Build-out Intersection Conditions (with Elementary School) 86
Table 7	Phase 1 Baseline 2017 with Project – Study Area Intersection Level of Service 88
Table 8	Phase 2 Baseline 2019 with Project – Study Area Intersection Level of Service 89
Table 9	Phase 3 Baseline 2021 with Project (without School) – Study Area Intersection Level of Service 90
Table 10	Phase 3 Baseline 2021 with Project (with School) – Study Area Intersection Level of Service 91
Table 11	Recommended Project Study Area Mitigation Measures 92
Table 12	Project Fair Share Analysis 92
Table 13	Preliminary Feasibility Analysis of Proposed Project Mitigation Measures ... 97

SECTION I INTRODUCTION AND EXECUTIVE SUMMARY

The purpose of this traffic impact analysis (TIA) is to identify roadway infrastructure requirements and to evaluate traffic conditions associated with the proposed Armstrong Ranch development. The results of this analysis have been used to identify roadway and intersection infrastructure improvements, including off-site mitigations, which accommodate traffic generated by Armstrong Ranch and surrounding developments in accordance with City of Ontario circulation network minimum level of service LOS D criteria for roadway segments and LOS E for intersections.

The Armstrong Ranch project location and vicinity is shown on Figure 1. The proposed 199-acre project consists of up to 994 single-family dwelling units without development of an elementary school, and 944 dwelling units including a 1000-student elementary school. The Project site plan is shown on Figure 2.

The project is anticipated to be completed in 2021 with three project phases for the purpose of this study. Phases 1, 2, and 3 are each analyzed in this study and correspond to years 2017, 2019, and 2021, respectively. These phase years represent milestones in site development (completion of two planning areas each) and are consistent with phased construction of the on-site circulation system infrastructure. Figure 3 shows the Project phasing plan analyzed in this study. The project phases are summarized as follows:

- Phase 1 (2017) – Development of Planning Areas 1 and 2 bordering Vineyard Avenue on the westerly portion of the site;
- Phase 2 (2019) – Development of Planning Areas 3 and 4 on the central portion of the site; and
- Phase 3 (2021) – Development of Planning Areas 6A, 6B, and 7 located on the easterly portion of the site between Hellman Avenue and the Cucamonga Channel.

Traffic generation was completed for each project phase based on the latest Institute of Transportation (ITE) trip generation rates. Because the site is not a mixed-use site, no internal trip capture is appropriate for this study with the exception of the alternate Phase 3 scenario that includes development of an elementary school. For this scenario, 60% of school related trips were considered to be internal and 40% external.

Project trip generation rates were reviewed and approved by the City of Ontario prior to assigning these trips to the study area roadway network for analysis. The project external trip distribution used for each Project Phase was derived from the San Bernardino Association of Governments (SANBAG) SBTAM model runs.

Following assignment to the study area network per the SBTAM trip distribution, project traffic volumes were combined with existing traffic volumes and cumulative traffic volumes from other identified development projects. Traffic volumes for this study were conducted in late March of 2015. Traffic volumes for other development projects were taken directly from the approved traffic studies for those projects.

Total study network traffic volumes were analyzed for each Project phase year to confirm planned roadway and intersection infrastructure improvements and provided level of service (LOS). Roadway link LOS was determined based on volume-to-capacity (v/c) analysis using City of Ontario General Plan roadway capacities. Intersection LOS was determined using the 2000 Highway Capacity Manual (HCM) signalized/unsignalized operational methods.

This study confirms that the proposed Specific Plan infrastructure improvements will provide acceptable and desirable LOS along the roadways and intersections providing access to the site and are appropriately sized for forecast Project volumes. This study also confirms that for Baseline 2021 with Project Phase 3 (with elementary school) conditions there is no significant impact to peak hour operation of SR-60. Finally, this study identifies a Project fair share contribution and estimated order of magnitude construction cost for recommended mitigation measures at six (6) off-site intersections that do not meet City of Ontario LOS criteria considering future cumulative project and Armstrong Ranch development volumes.

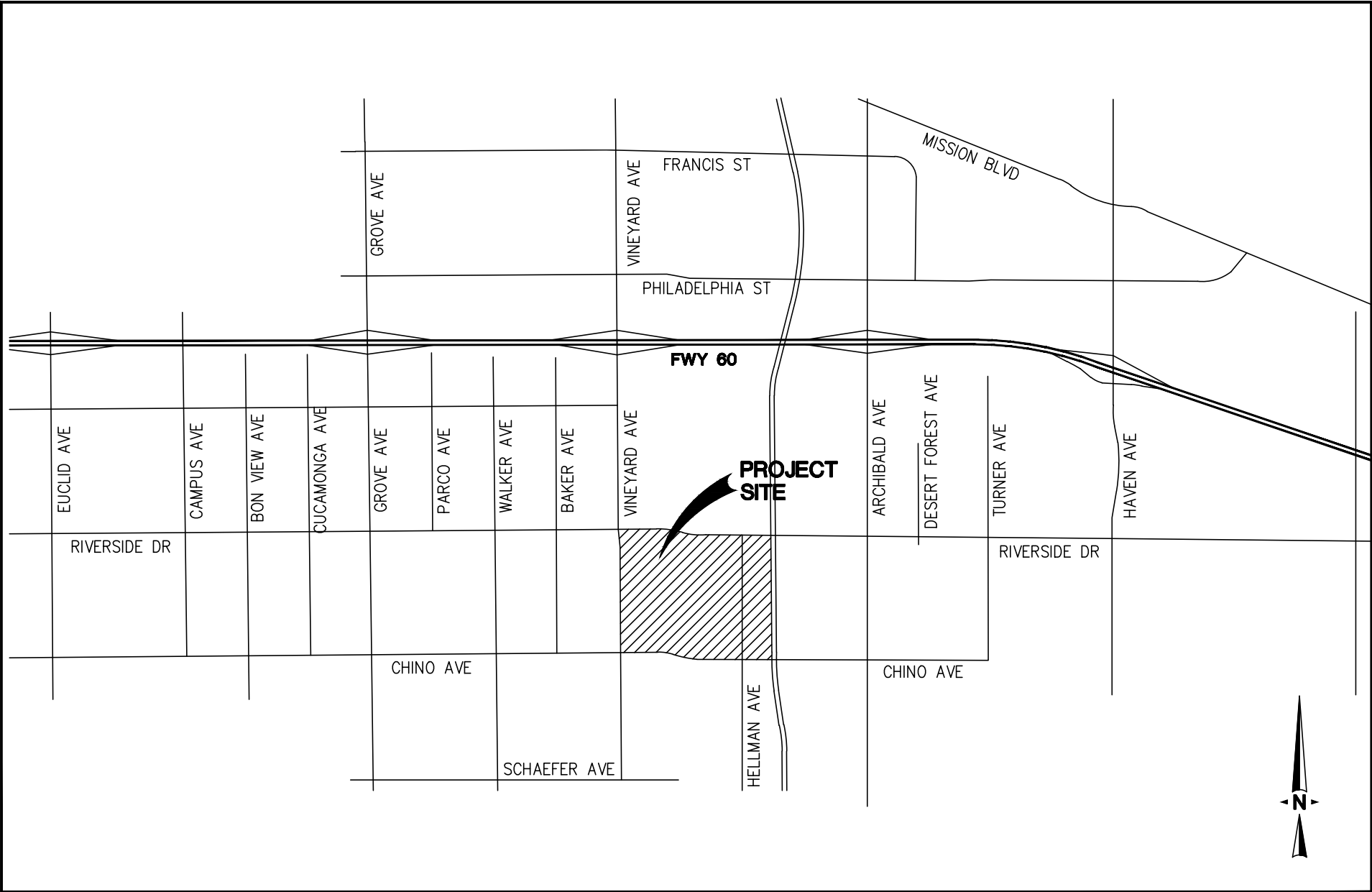

PREPARED BY:



Stantec

**ARMSTRONG RANCH
TRAFFIC IMPACT STUDY
ONTARIO, CA**

**FIGURE 1
PROJECT LOCATION
AND VICINITY MAP**





PREPARED BY:



**ARMSTRONG RANCH
TRAFFIC IMPACT STUDY
ONTARIO, CA**

**FIGURE 2
PROPOSED ARMSTRONG RANCH SITE PLAN**

LEGEND

-  - PHASE 1
-  - PHASE 2
-  - PHASE 3

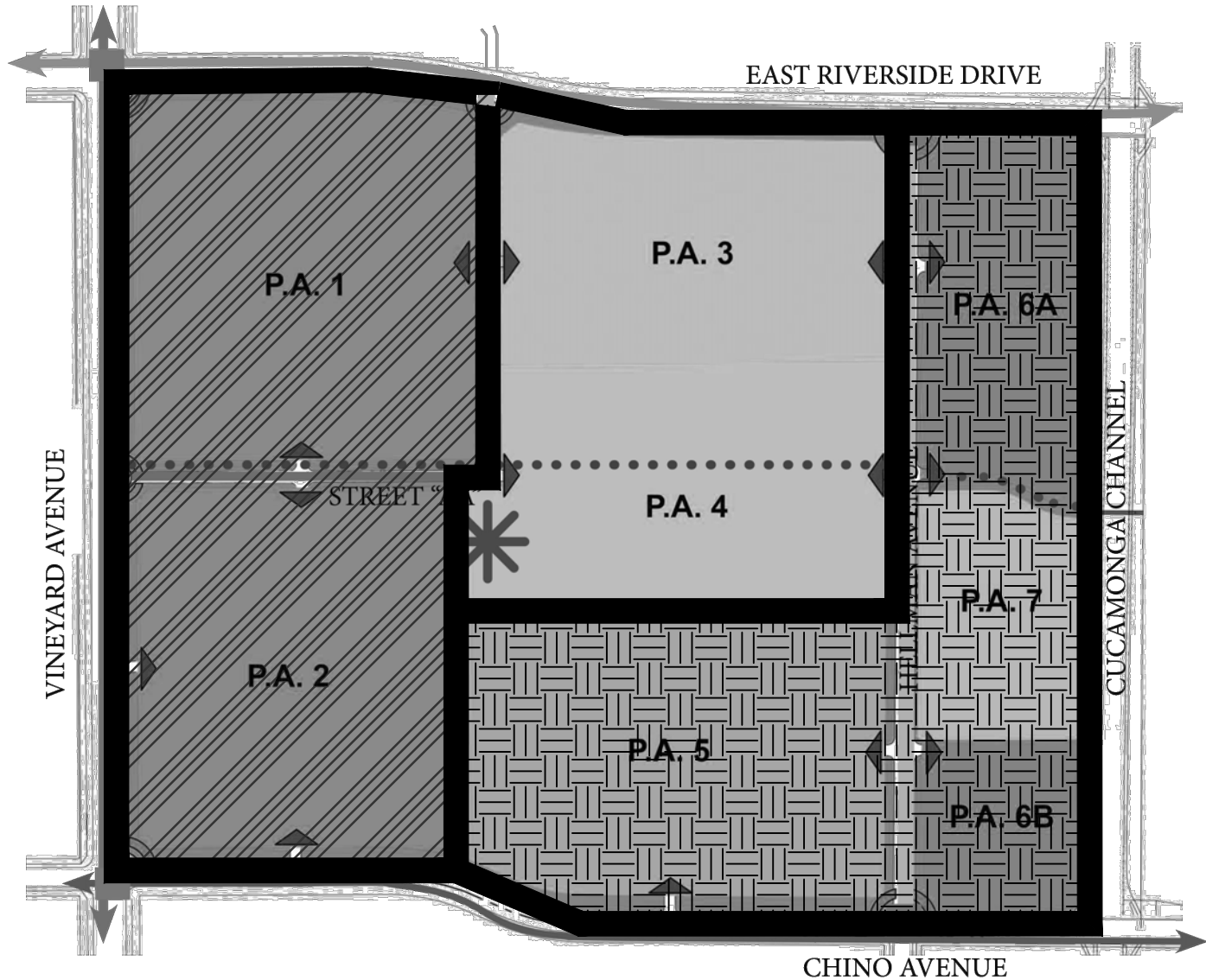

5

PREPARED BY:



ARMSTRONG RANCH
TRAFFIC IMPACT STUDY
ONTARIO, CA

FIGURE 3
TRAFFIC STUDY PROJECT
PHASING PLAN

SECTION II EXISTING STUDY AREA CONDITIONS

A. PROJECT STUDY AREA

The project study area is shown on Figure 4 together with existing intersection geometrics and controls and the number of through lanes for roadways surrounding the project area. The Project site and most adjacent areas are currently undeveloped and have formerly been used for agricultural and dairy uses. Northwest of the site there is residential and mobile home park development, and a relatively small amount of retail/commercial use. Directly north of the site is the Whispering Lakes Golf Course. Northeast of the site there are community center, residential, and commercial/retail uses.

Existing roadways in vicinity of the project include Vineyard Avenue, Riverside Drive, Chino Avenue, Grove Avenue, and Archibald Avenue. State Route 60 is located approximately 0.75 miles north of the site and Interstate 15 is located approximately 2.8 miles east.

Figure 4 shows that the following twenty-two (22) intersections are included in this study for analysis:

1. Grove Avenue/Francis Street
2. Vineyard Avenue/Francis Street
3. Grove Avenue/Philadelphia Street
4. Vineyard Avenue/Philadelphia Street
5. Archibald Avenue /Philadelphia Street
6. Haven Avenue/Philadelphia Street
7. Grove Avenue/SR-60 Westbound Ramps
8. Grove Avenue/SR-60 Eastbound Ramps
9. Vineyard Avenue/SR-60 Westbound Ramps
10. Vineyard Avenue/SR-60 Eastbound Ramps
11. Archibald Avenue/SR-60 Westbound Ramps

12. Archibald Avenue/SR-60 Eastbound Ramps
13. Euclid Avenue/Riverside Drive
14. Campus Avenue/Riverside Drive
15. Grove Avenue/Riverside Drive
16. Vineyard Avenue/Riverside Drive
17. Archibald Avenue/Riverside Drive
18. Turner Avenue/Riverside Drive
19. Haven Avenue/Riverside Drive
20. Grove Avenue/Chino Avenue
21. Vineyard Avenue/Chino Avenue
22. Archibald Avenue/Chino Avenue

A.1 Existing Traffic Volumes

Figures 5A and 5B show existing (March 2015) weekday am and pm peak hour intersection turning movement volumes within the project study area, respectively. Figure 6 shows existing weekday 24-hour volumes on roadway segments. Traffic Data was collected on Tuesday, March 31, 2015 for this study by National Data Collection and Surveying Services (NDS) and is included in the appendix. Schools were in session when this data was collected.

A.2 Project Implementation Year Baseline Volumes

For this analysis, the Project was analyzed in three (3) phases, 2017, 2019, and 2021. Baseline Project phase year traffic volumes have been developed by factoring existing 2015 volumes by an ambient growth rate of 1% per year to the phase year (for 2, 4, or 6 years) and then adding traffic from identified future cumulative development projects. This growth rate reflects an anticipated increase in traffic volumes associated with regional traffic growth. Ten (10) cumulative development projects were identified by the City of Ontario for the Project study and are shown on Figure 7. Figure 7 identifies the project phase year by which each cumulative project is anticipated to have been implemented and in which its traffic was added to existing and ambient growth traffic

July 2016

volumes. These projects include the Watson Industrial Park which is located approximately 2.5 miles south of the Armstrong Ranch site. At completion, this project will develop 3.872 million square feet of light industrial use. The Watson Industrial Park site will be developed in three phases completed in 2016, 2017, and 2018. The industrial park traffic generated by each of these phase years is included at study area intersections for each phase year of the Armstrong Ranch project. The volumes assigned to each affected study area intersection are as identified in the Watson Industrial Park FEIR, dated November 18, 2015.

Figures 8A and 8B show Phase 1 Baseline 2017 weekday am and pm peak hour intersection turning movement volumes within the project study area, respectively. Figure 9 shows Baseline 2017 weekday 24-hour volumes on roadway segments.

Figures 10A and 10B show Phase 2 Baseline 2019 weekday am and pm peak hour intersection turning movement volumes within the project study area, respectively. Figure 11 shows Baseline 2017 weekday 24-hour volumes on roadway segments.

Figures 12A and 12B show Phase 3 Baseline 2021 weekday am and pm peak hour intersection turning movement volumes within the project study area, respectively. Figure 13 shows Baseline 2017 weekday 24-hour volumes on roadway segments.

A.3 Existing and Project Implementation Year Baseline Level of Service (LOS) Analysis

To provide a detailed analysis of existing peak hour and Baseline Project phase year traffic conditions within the study area, the 2000 Highway Capacity Manual (HCM) Signalized Method, including 2007 updates, was used to analyze existing signalized study area intersections. Using this method, the average control delay in seconds per vehicle is calculated for each intersection considering unique features including turning movement volumes, traffic signal phasing and timing, and the number and types of lanes on each approach. The control delay per vehicle is used to determine level of service at signalized intersections as shown on Table 1A.

Using the 2000 HCM operations method for unsignalized intersections, level of service is based on worst case approach delay as shown on Table 1B.

Table 2 shows the results of intersection level of service analysis for the study area intersections, separated by signalized/unsignalized control, under existing 2015 conditions and Tables 3, 4 and 5 for Baseline 2017, 2019, and 2021 conditions, respectively.

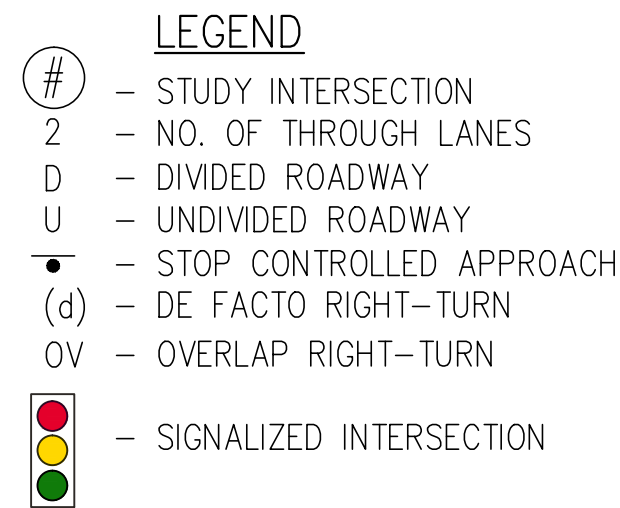
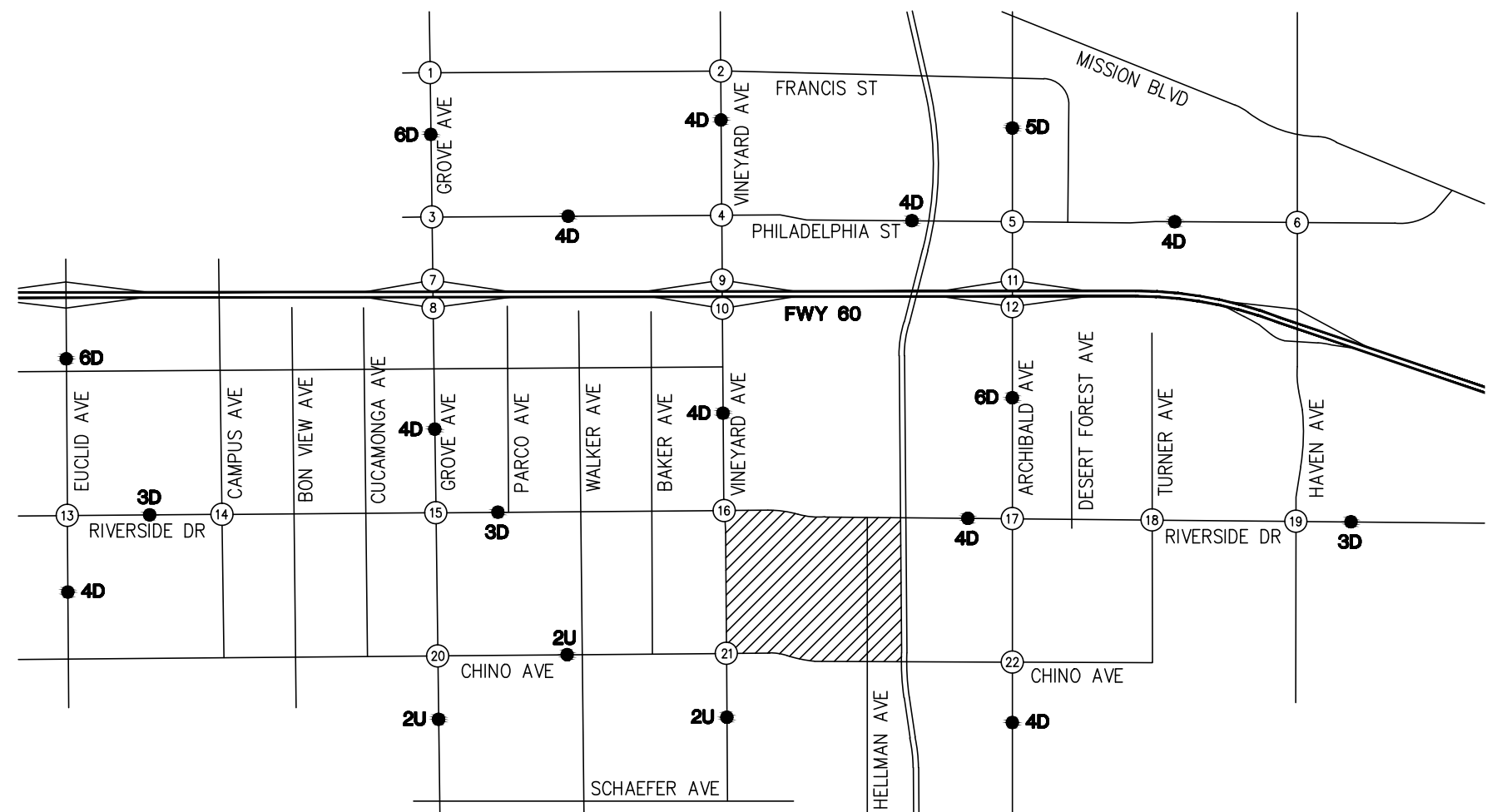
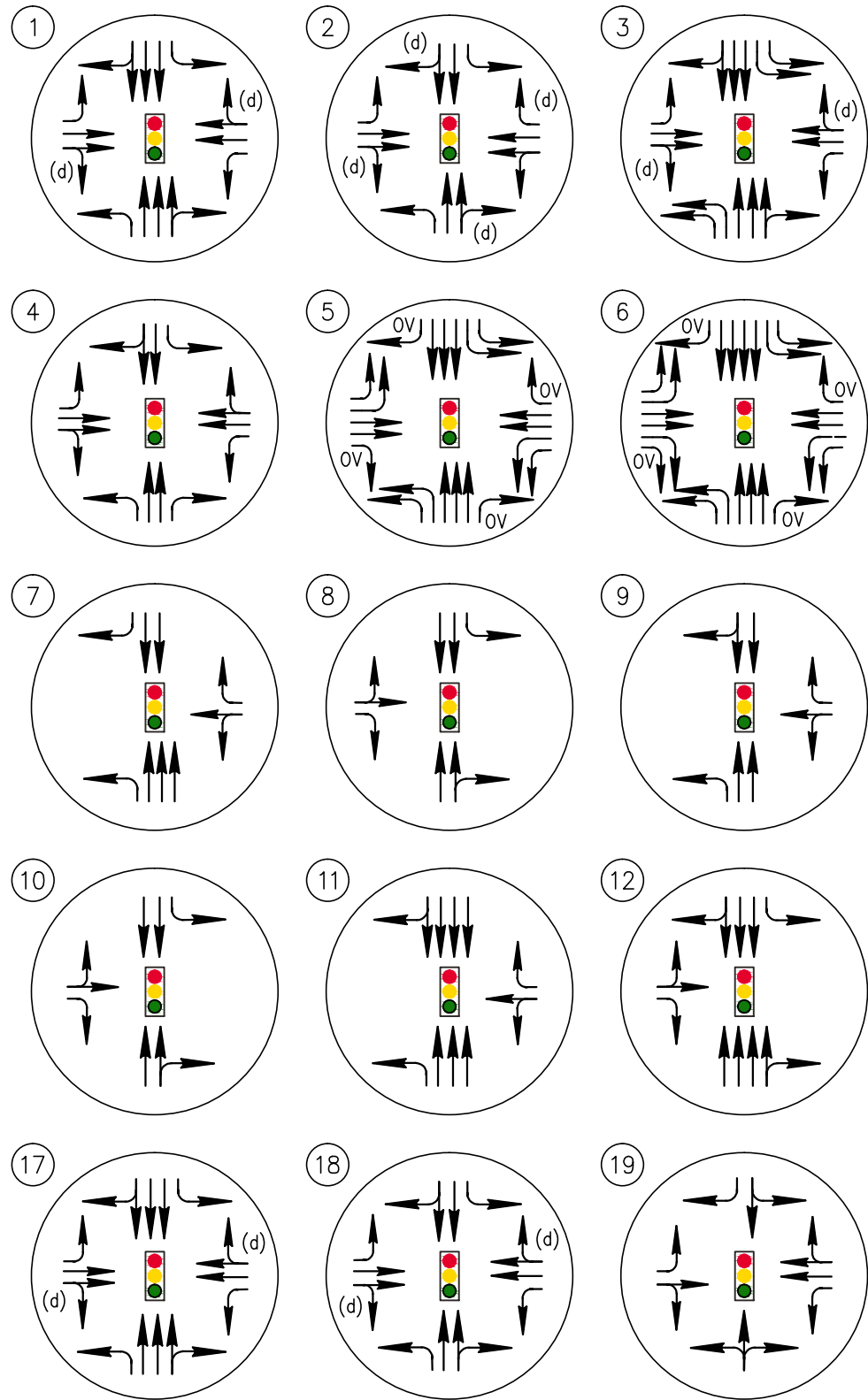

PREPARED BY:



**ARMSTRONG RANCH
TRAFFIC IMPACT STUDY
ONTARIO, CA**

**FIGURE 4
PROJECT STUDY AREA AND EXISTING
INTERSECTION GEOMETRICS AND CONTROLS**

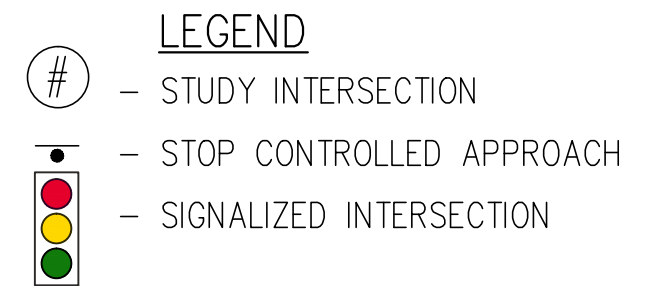
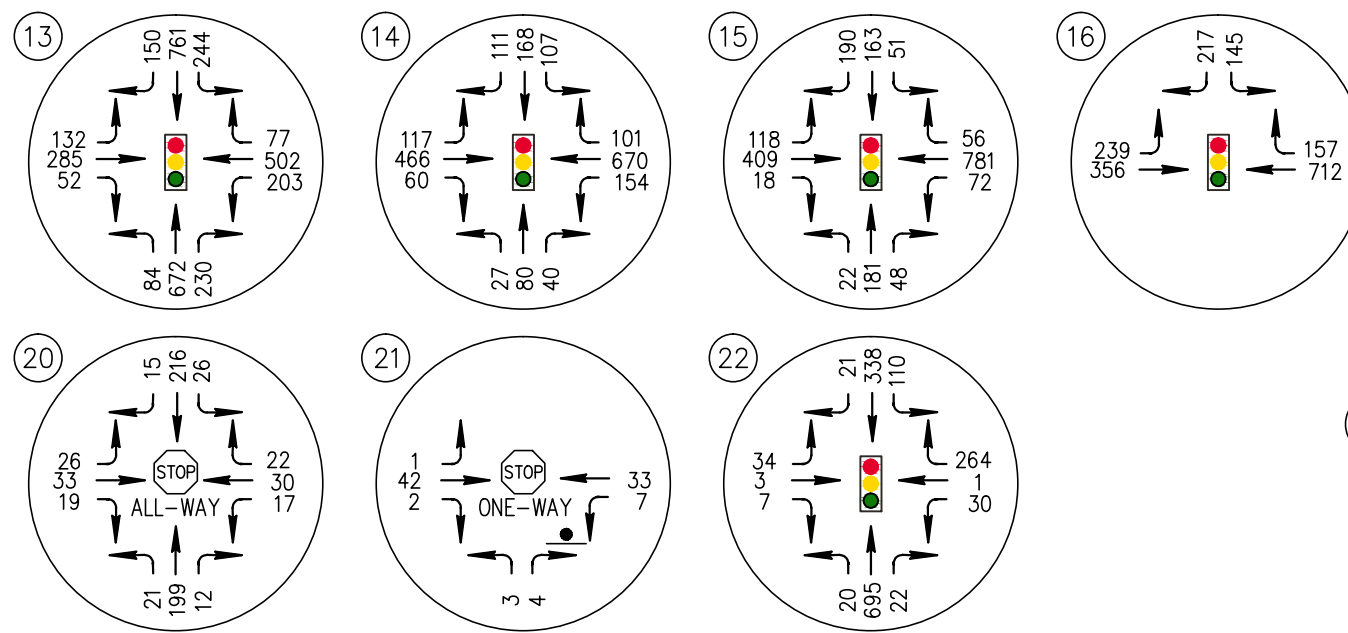
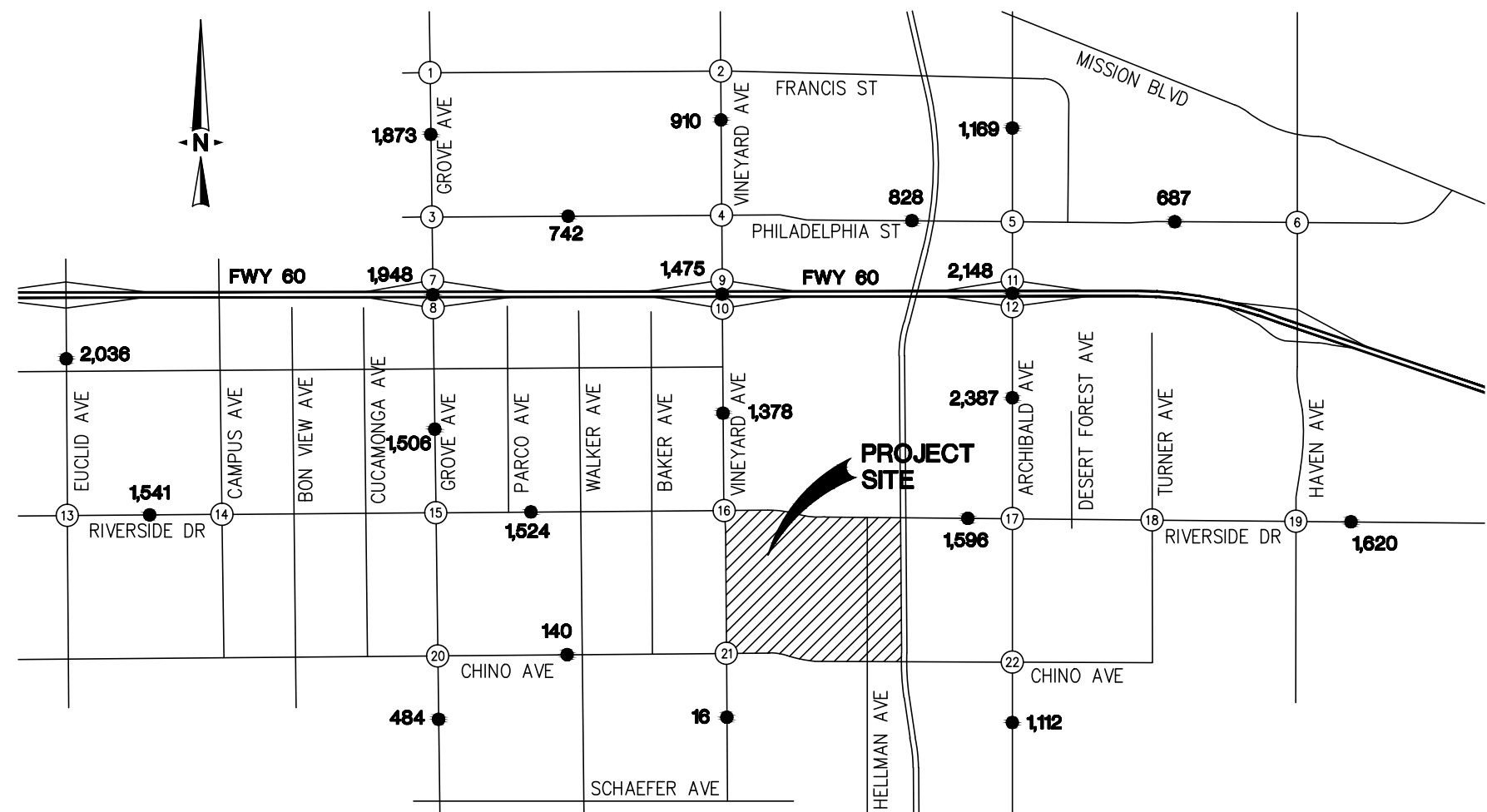
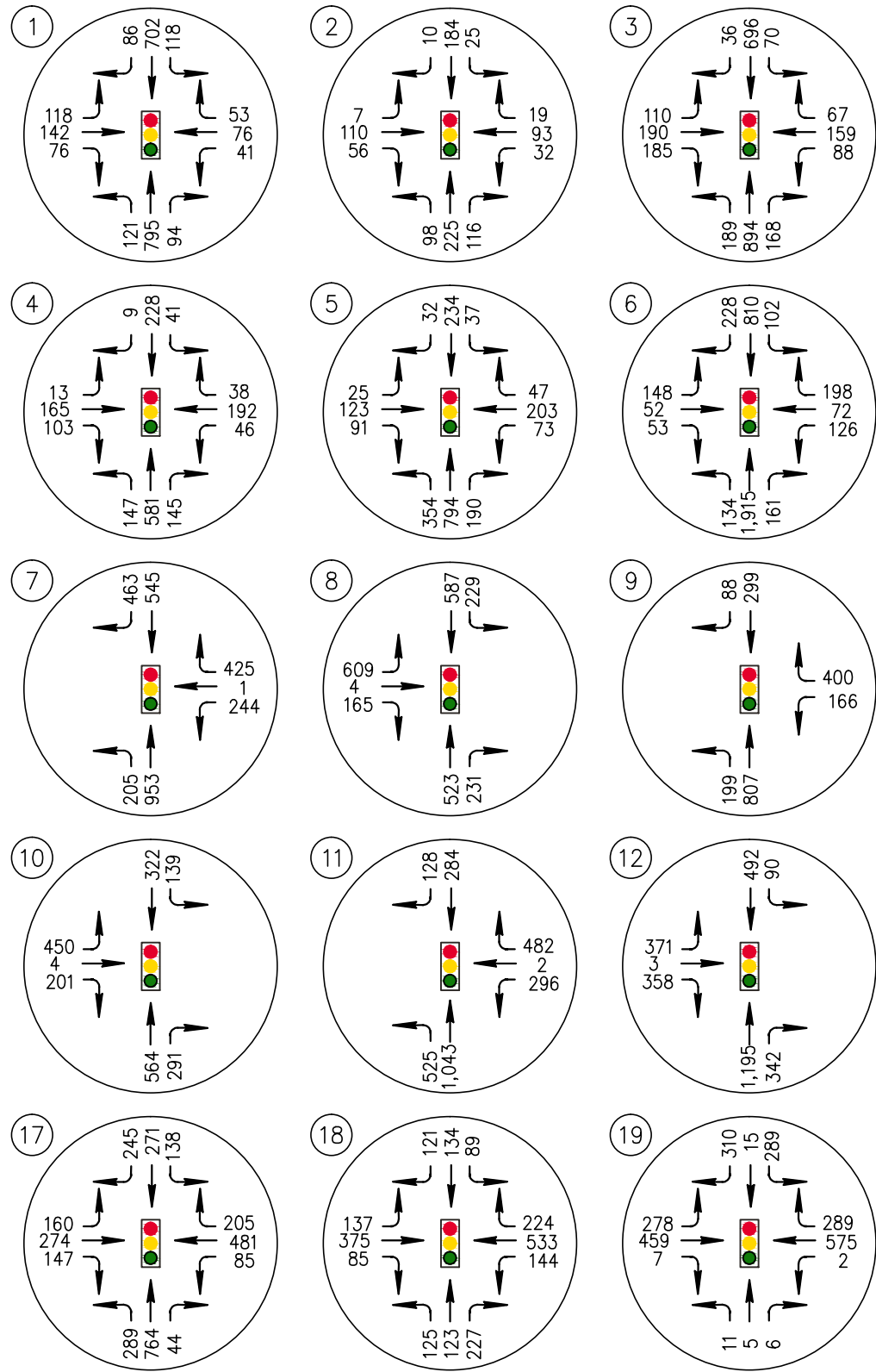

PREPARED BY:



**ARMSTRONG RANCH
TRAFFIC IMPACT STUDY
ONTARIO, CA**

**FIGURE 5A
EXISTING (2015) AM PEAK HOUR
STUDY AREA TRAFFIC VOLUMES**

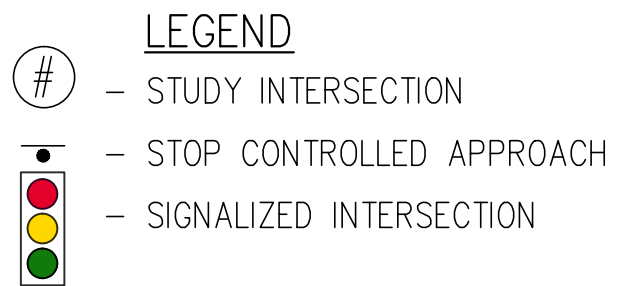
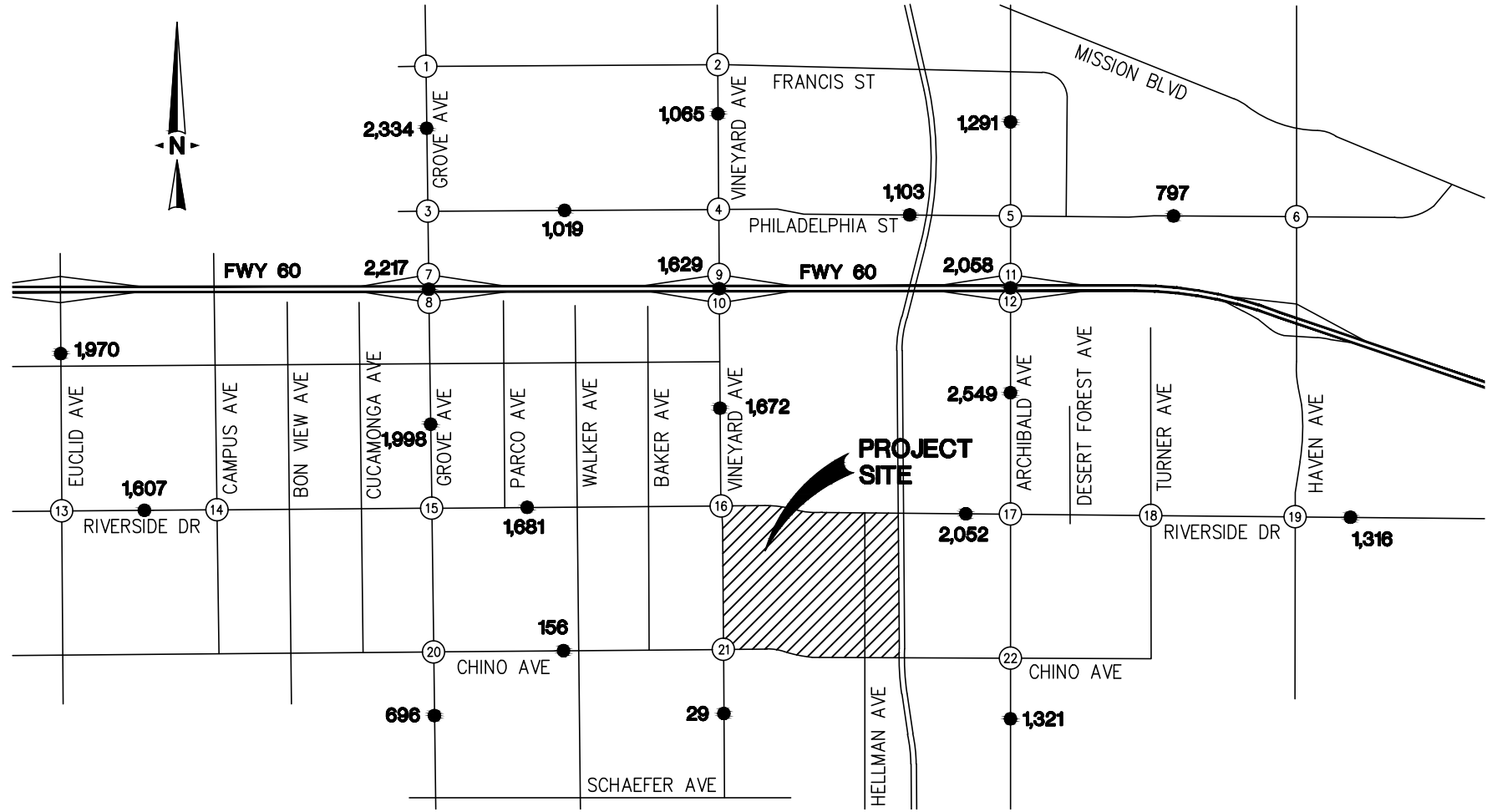
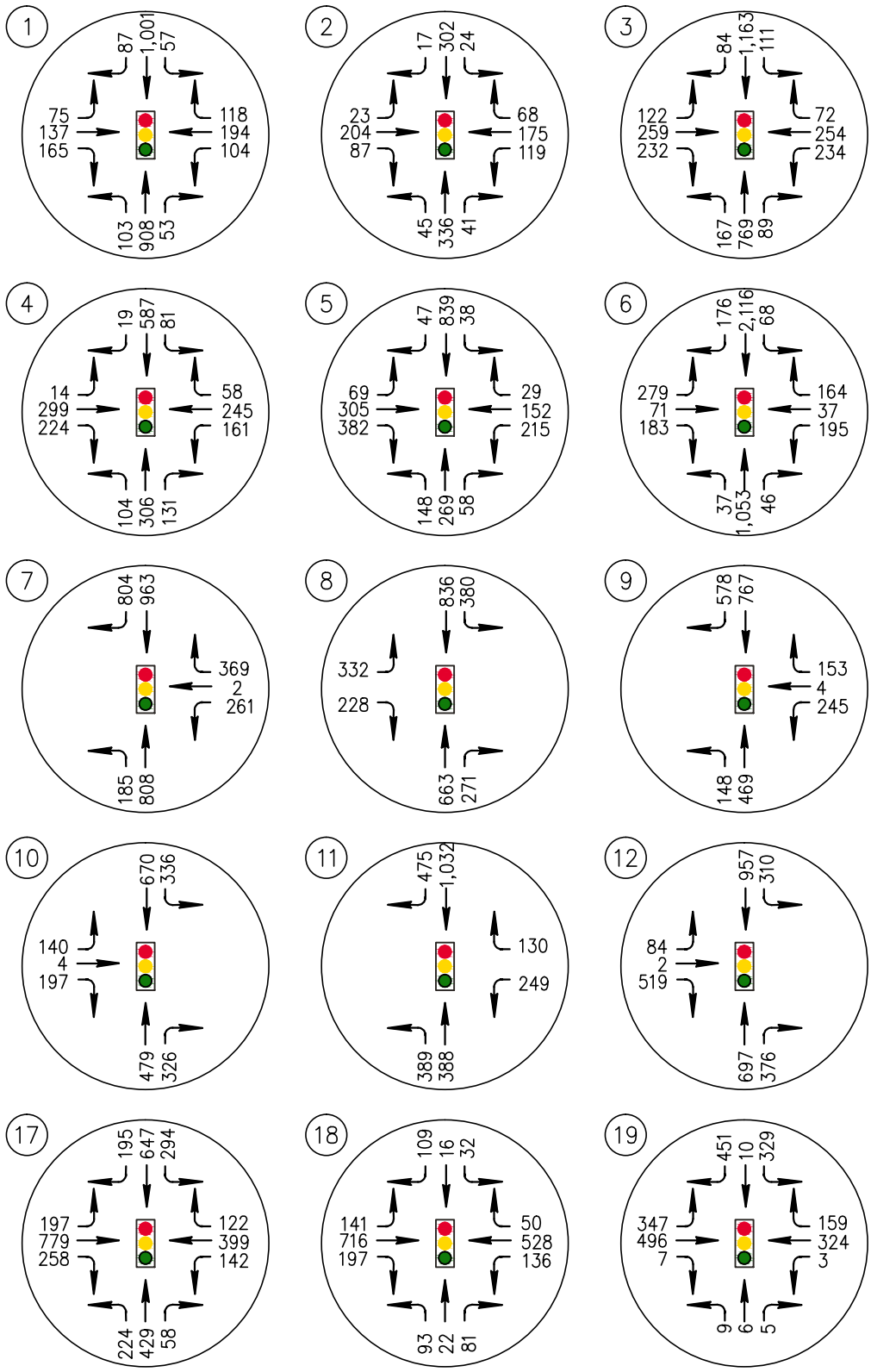

PREPARED BY:



**ARMSTRONG RANCH
 TRAFFIC IMPACT STUDY
 ONTARIO, CA**

**FIGURE 5B
 EXISTING (2015) PM PEAK HOUR
 STUDY AREA TRAFFIC VOLUMES**

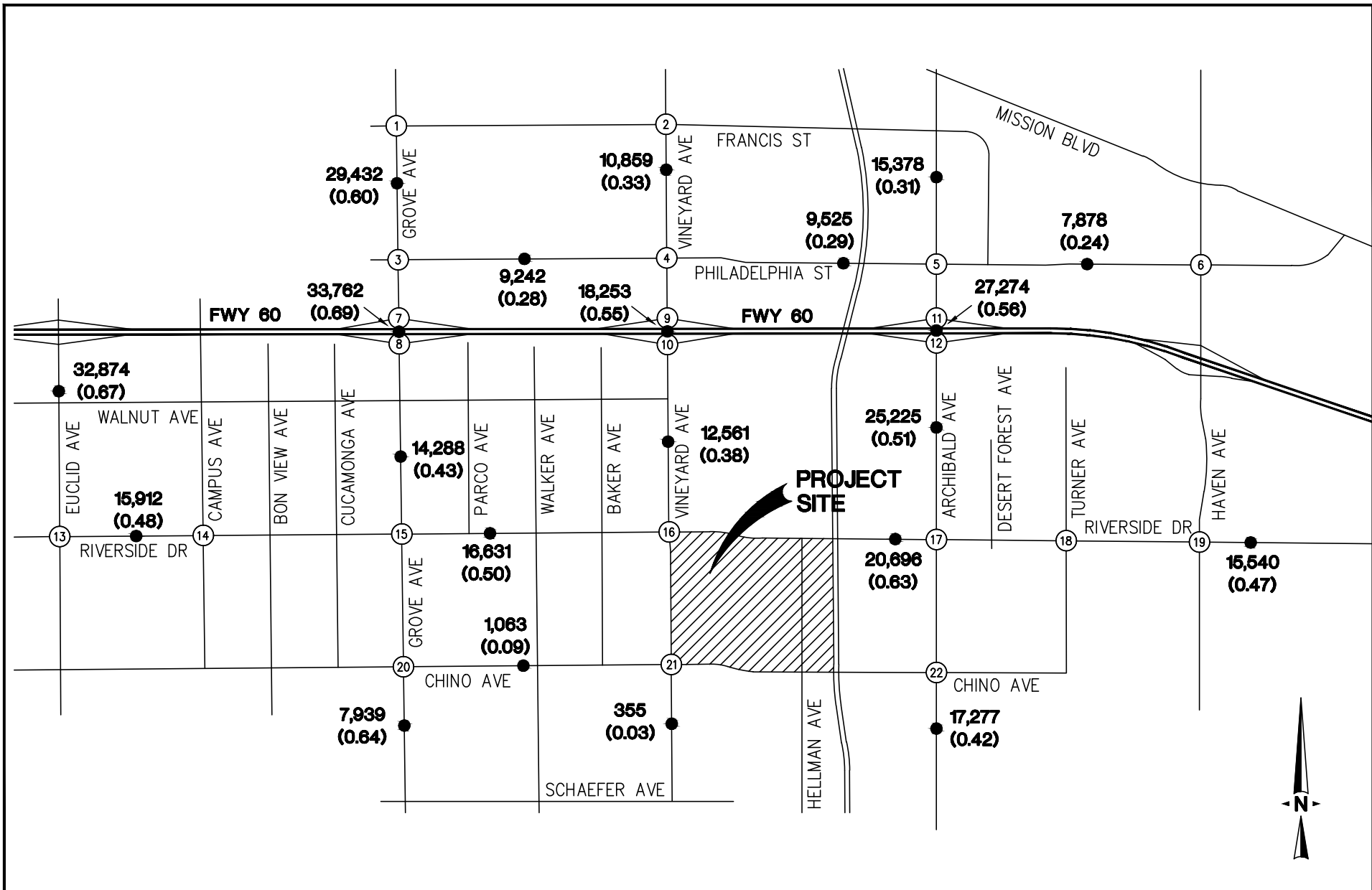

PREPARED BY:



**ARMSTRONG RANCH
TRAFFIC IMPACT STUDY
ONTARIO, CA**

**FIGURE 6
EXISTING (2015) WEEKDAY 24-HOUR
VOLUMES AND V/C RATIOS**

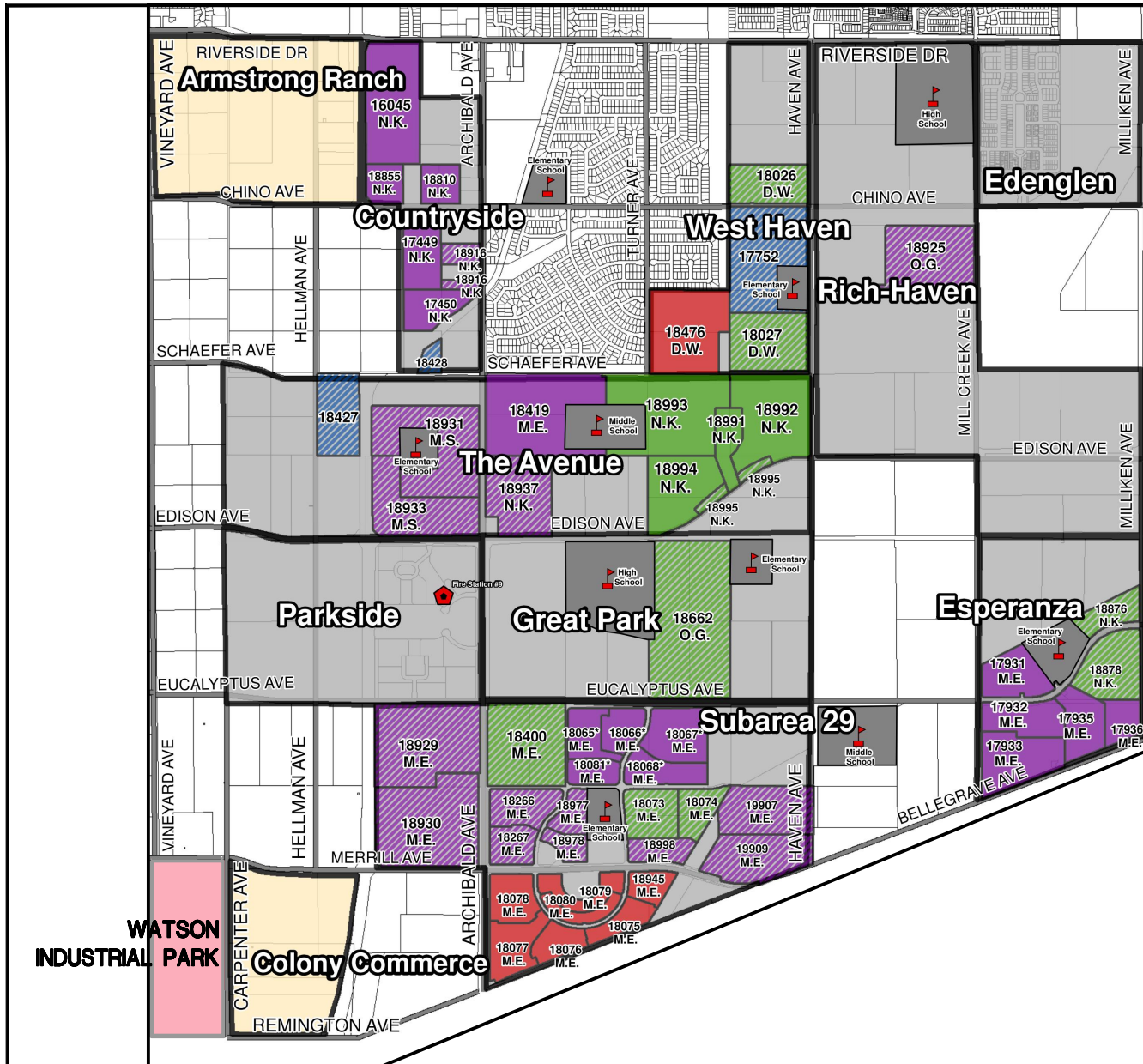

	CUMULATIVE DEVELOPMENTS	IMPLEMENTED BY
1.	COUNTRYSIDE	2017
2.	WEST HAVEN	2017
3.	EDENGLLEN	2017
4.	RICH-HAVEN	2017
5.	THE AVENUE	2017
6.	PARKSIDE	2017
7.	GREAT PARK	2017/2021
8.	ESPERANZA	2017
9.	SUBAREA 29	2017
10.	WATSON	2016/17/18

PREPARED BY:



**ARMSTRONG RANCH
TRAFFIC IMPACT STUDY
ONTARIO, CA**

**FIGURE 7
LOCATION OF OTHER CUMULATIVE
DEVELOPMENT PROJECTS**

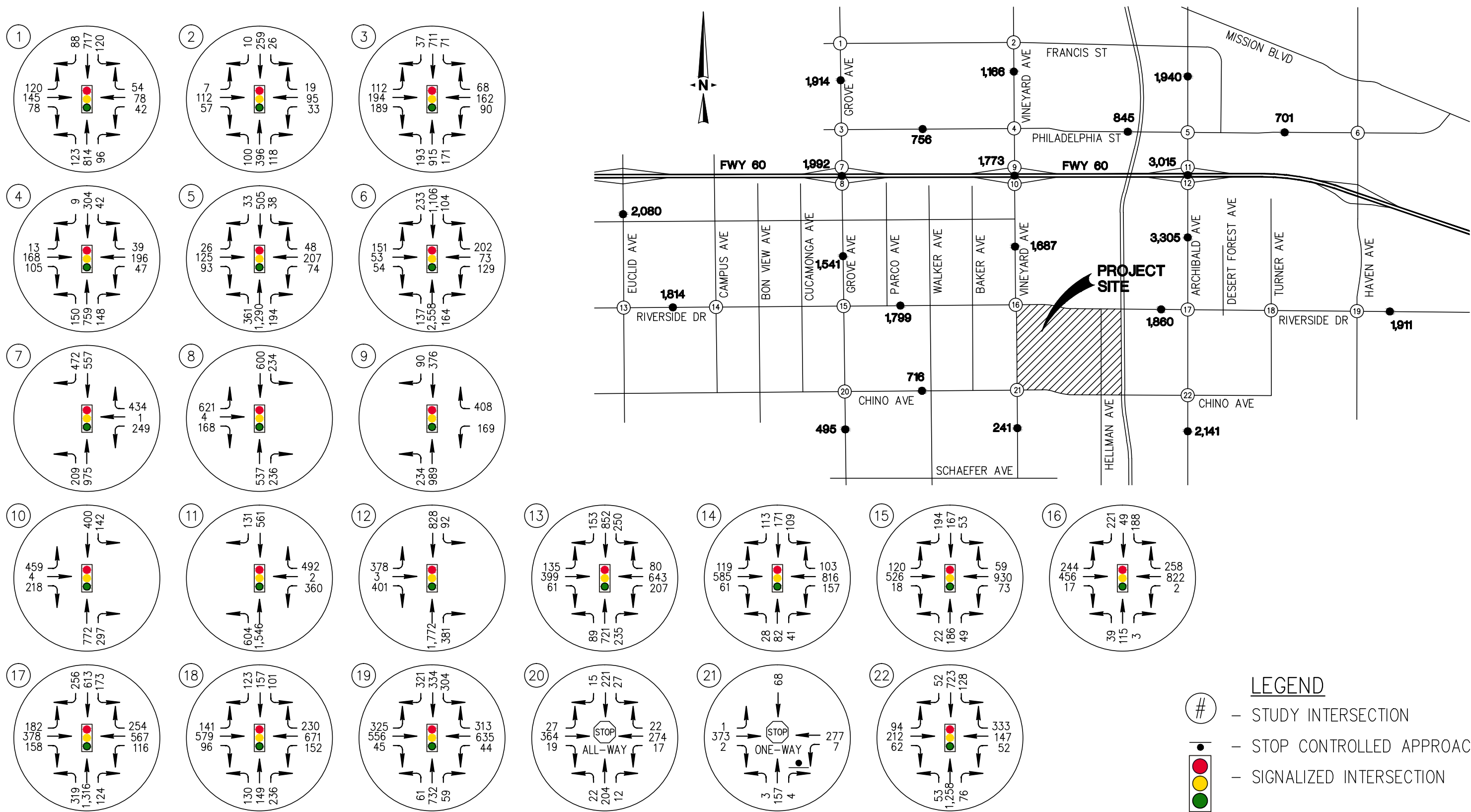

PREPARED BY:



**ARMSTRONG RANCH
TRAFFIC IMPACT STUDY
ONTARIO, CA**

**FIGURE 8A
PHASE 1 BASELINE 2017 AM PEAK HOUR
STUDY AREA TRAFFIC VOLUMES**

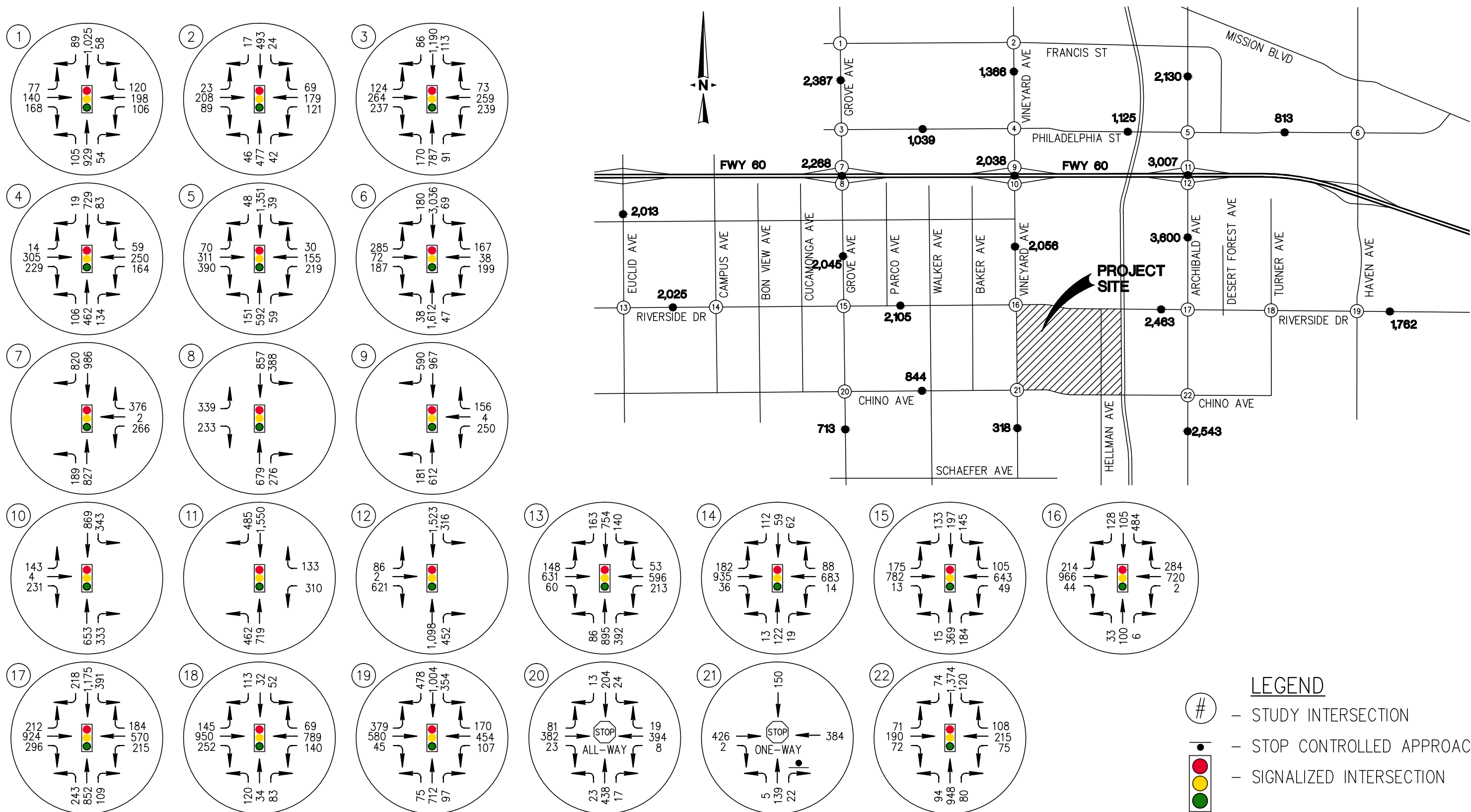

PREPARED BY:

**ARMSTRONG RANCH
 TRAFFIC IMPACT STUDY
 ONTARIO, CA**

**FIGURE 8B
 PHASE 1 BASELINE 2017 PM PEAK HOUR
 STUDY AREA TRAFFIC VOLUMES**

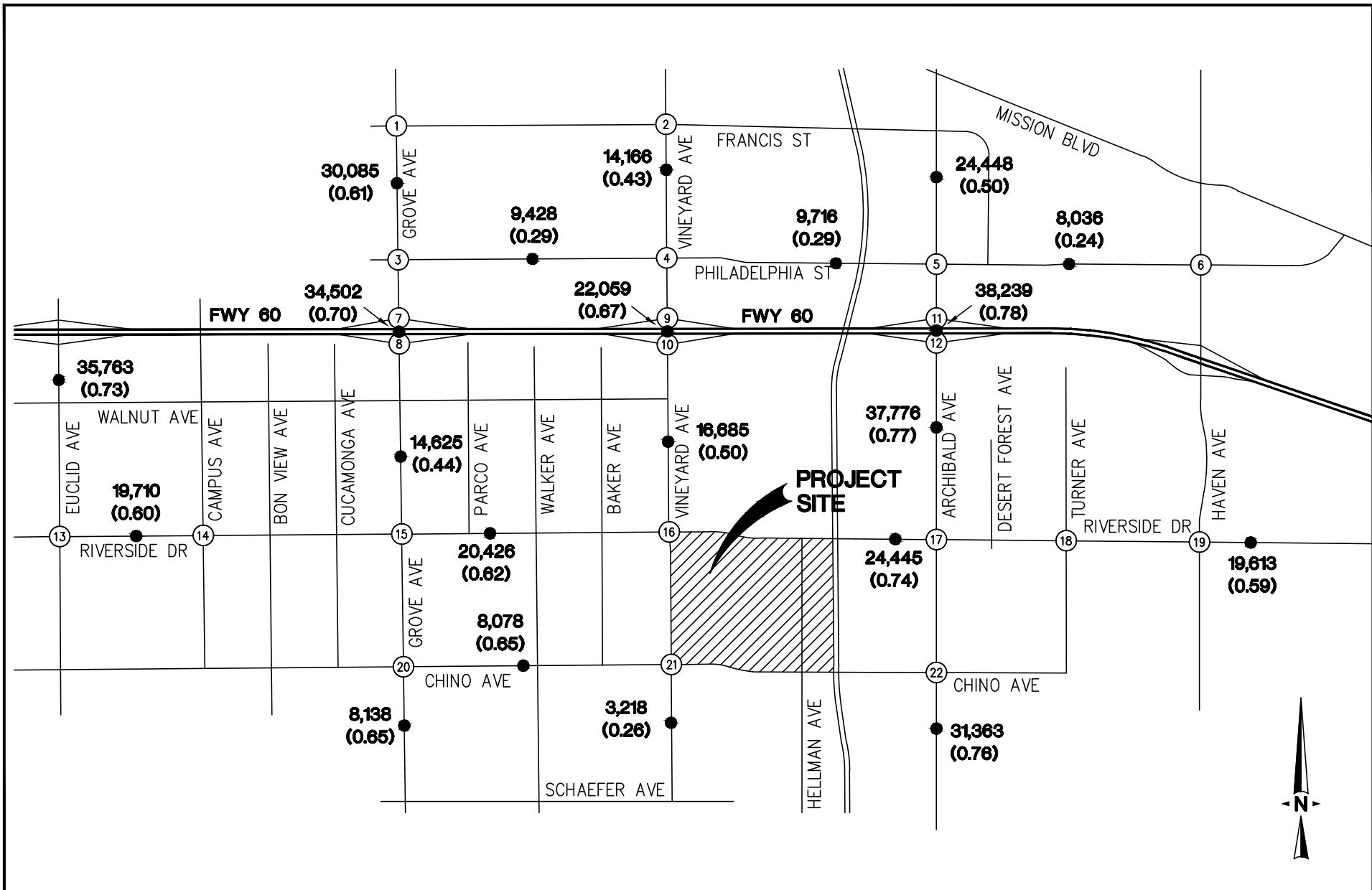

PREPARED BY:



**ARMSTRONG RANCH
TRAFFIC IMPACT STUDY
ONTARIO, CA**

**FIGURE 9
PHASE 1 BASELINE 2017 WEEKDAY
24-HOUR VOLUMES AND V/C RATIOS**

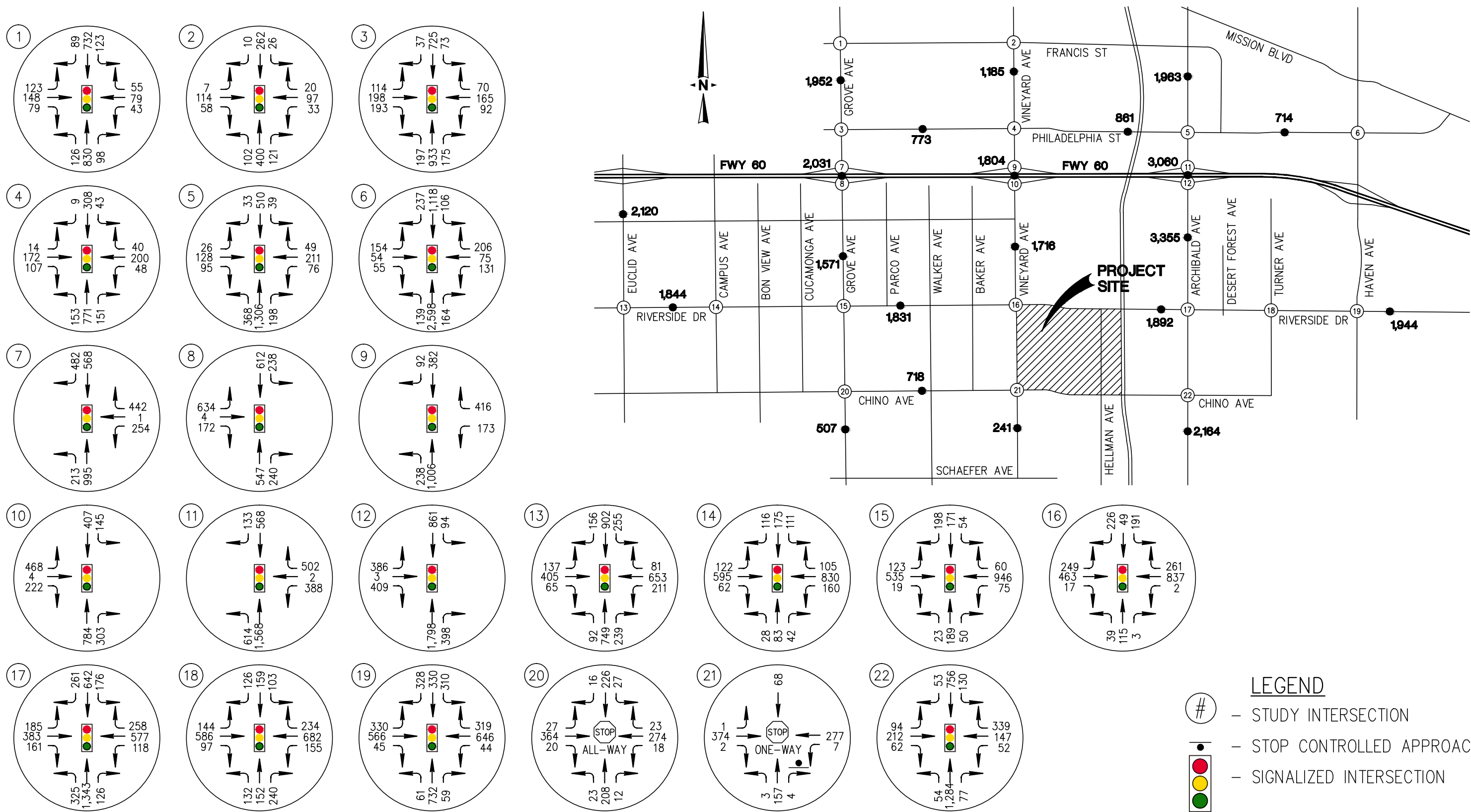

PREPARED BY:



**ARMSTRONG RANCH
TRAFFIC IMPACT STUDY
ONTARIO, CA**

**FIGURE 10A
PHASE 2 BASELINE 2019 AM PEAK HOUR
STUDY AREA TRAFFIC VOLUMES**

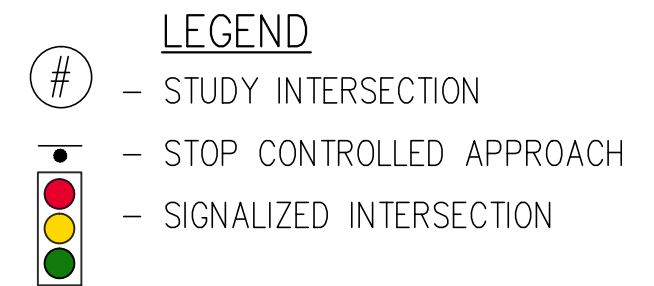
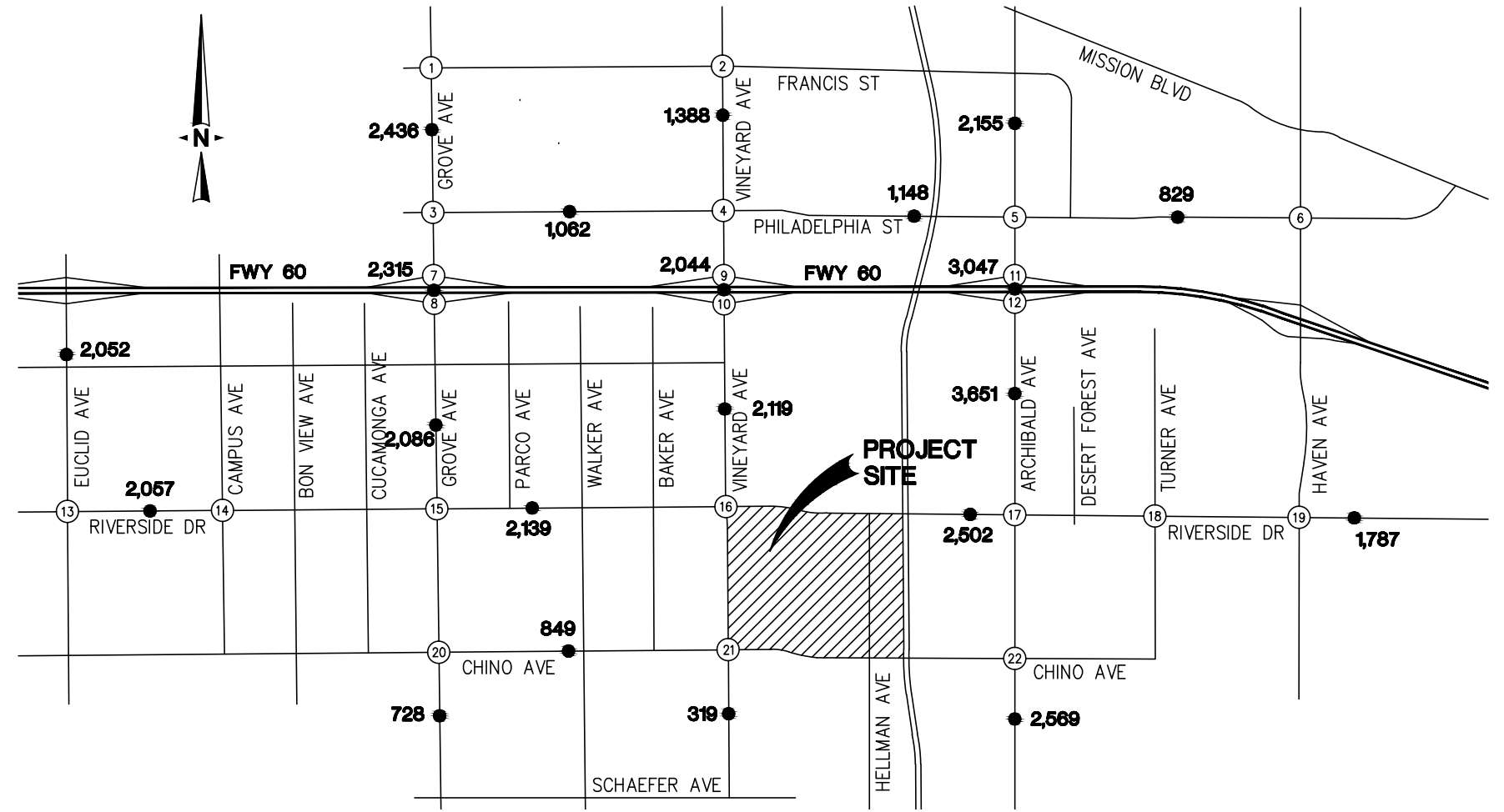
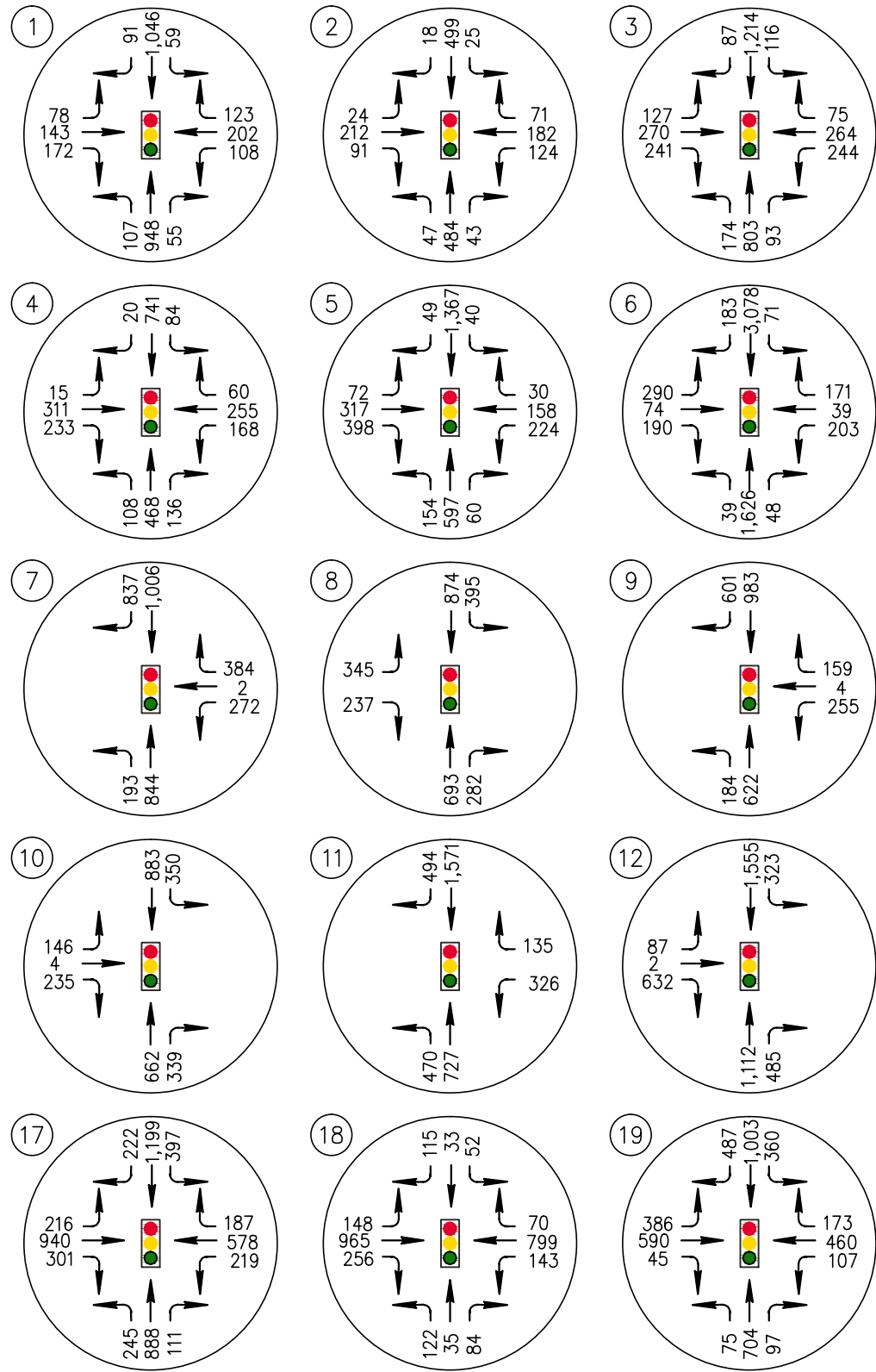

PREPARED BY:



**ARMSTRONG RANCH
TRAFFIC IMPACT STUDY
ONTARIO, CA**

**FIGURE 10B
PHASE 2 BASELINE 2019 PM PEAK HOUR
STUDY AREA TRAFFIC VOLUMES**

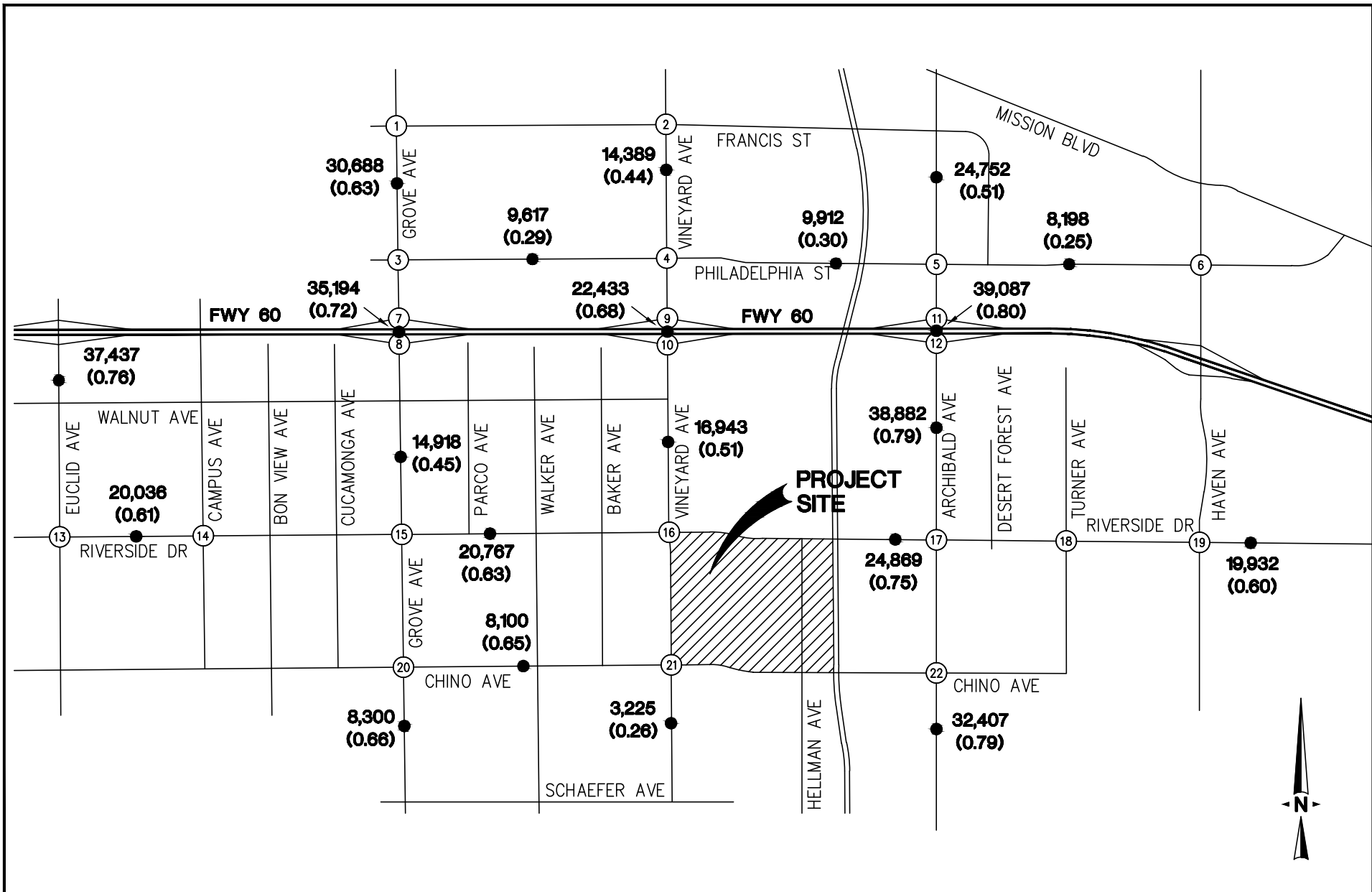

PREPARED BY:



**ARMSTRONG RANCH
TRAFFIC IMPACT STUDY
ONTARIO, CA**

**FIGURE 11
PHASE 2 BASELINE 2019 WEEKDAY
24-HOUR VOLUMES AND V/C RATIOS**

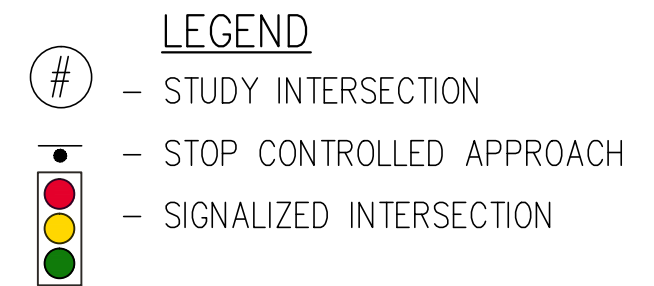
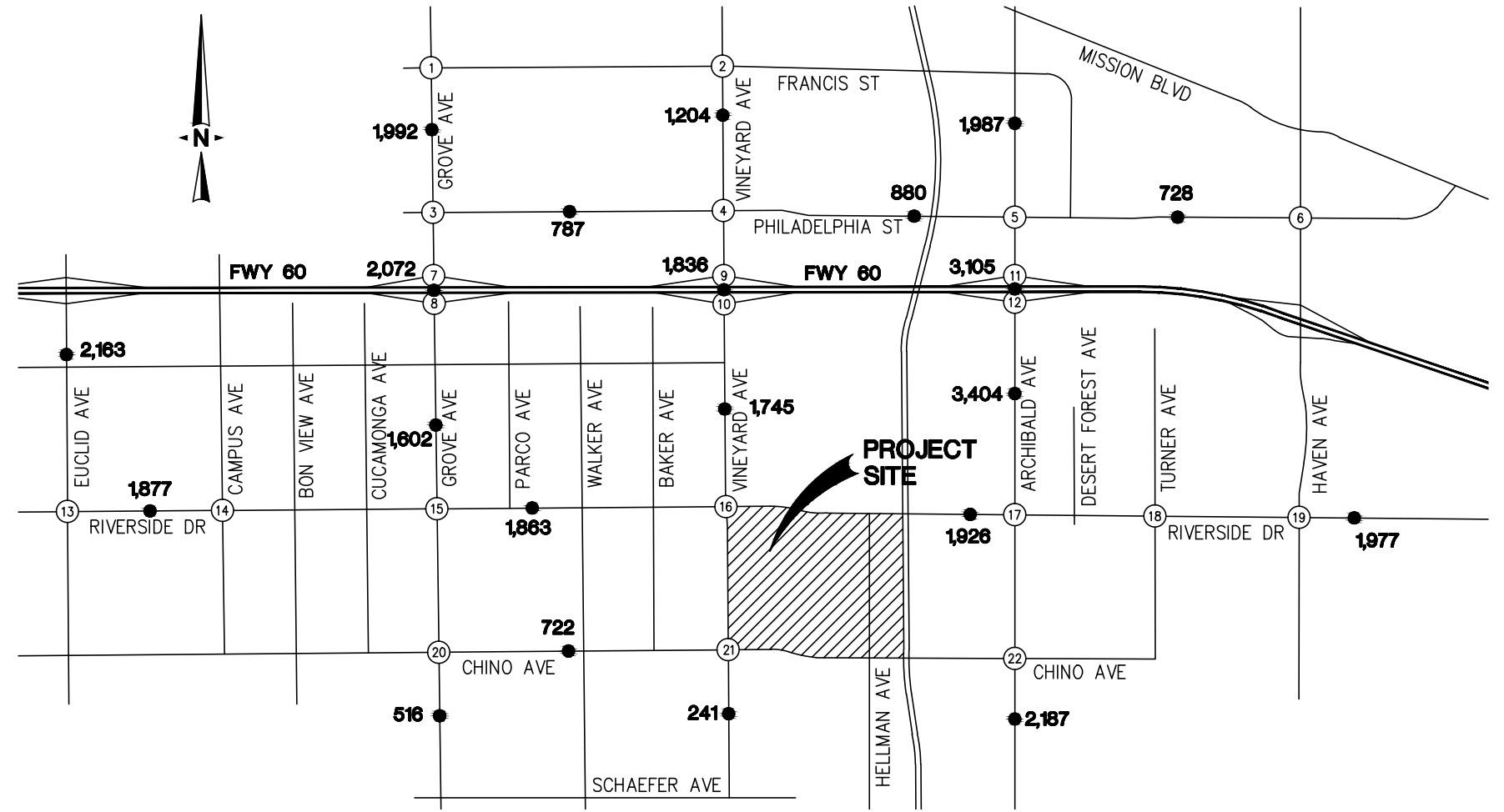
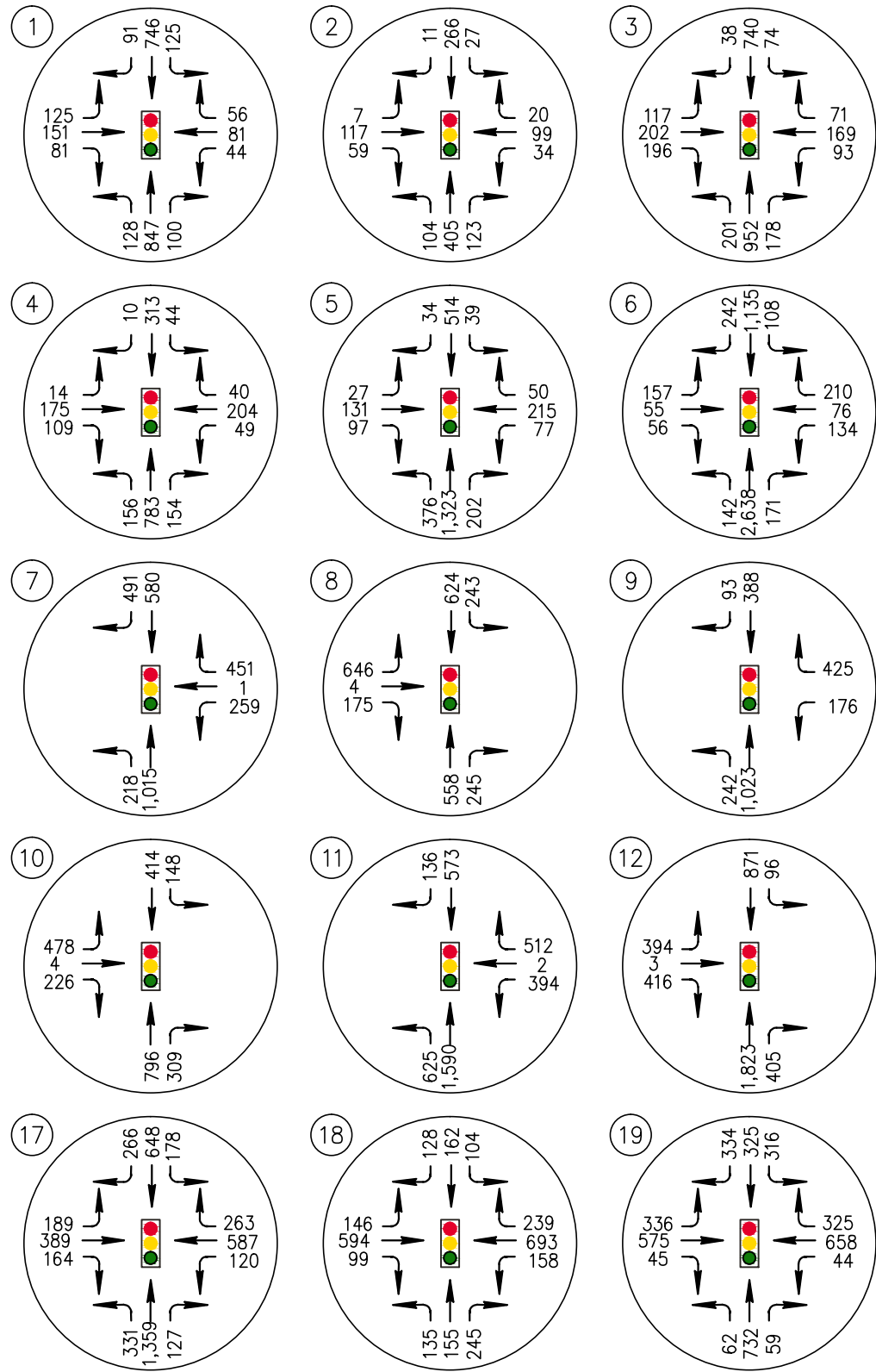

PREPARED BY:



**ARMSTRONG RANCH
TRAFFIC IMPACT STUDY
ONTARIO, CA**

**FIGURE 12A
PHASE 3 BASELINE 2021 AM PEAK HOUR
STUDY AREA TRAFFIC VOLUMES**

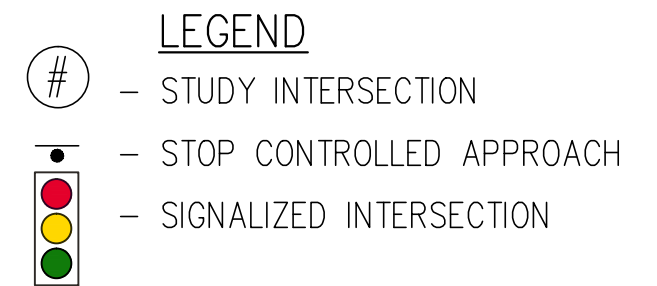
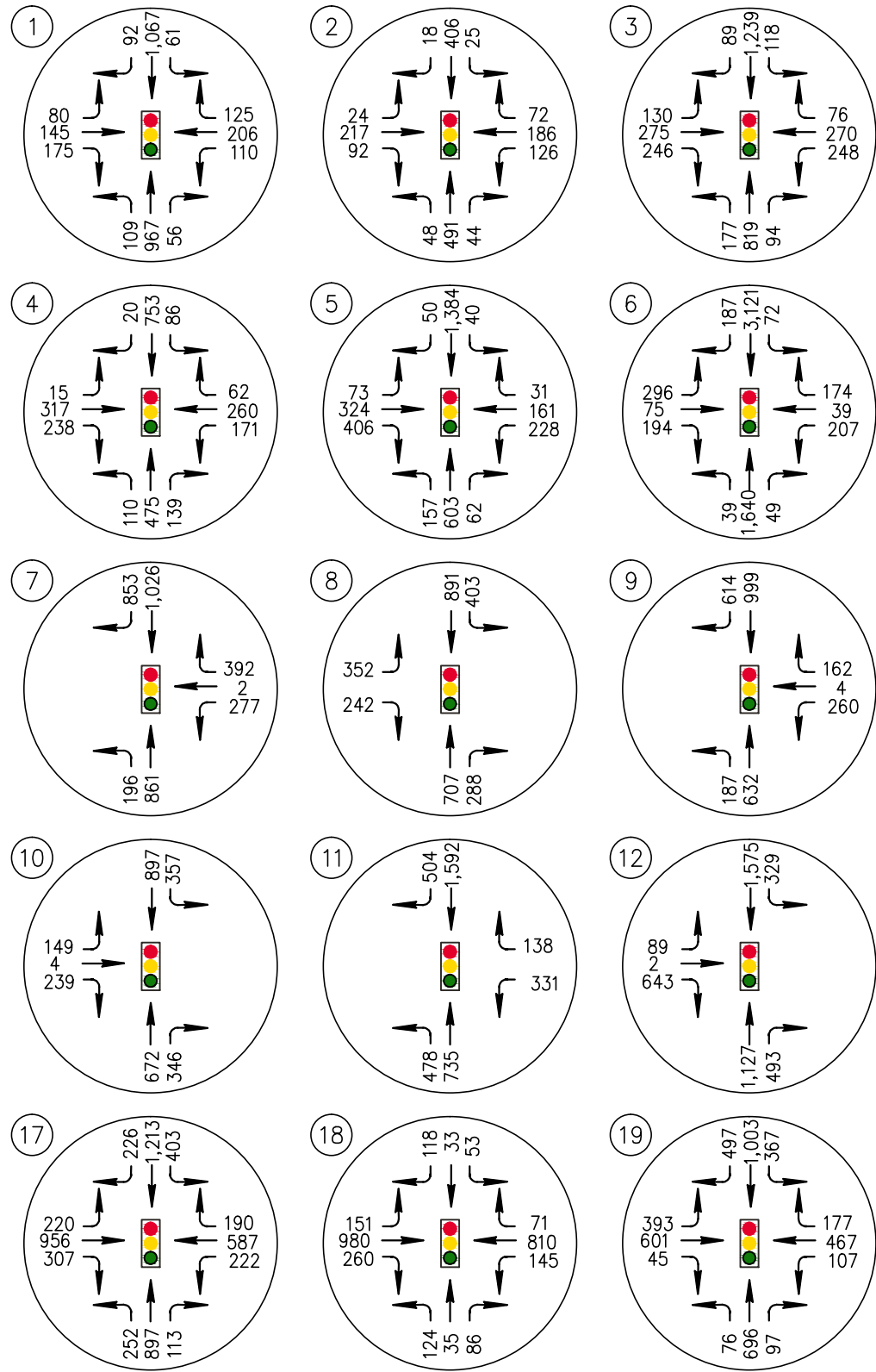

PREPARED BY:



**ARMSTRONG RANCH
TRAFFIC IMPACT STUDY
ONTARIO, CA**

**FIGURE 12B
PHASE 3 BASELINE 2021 PM PEAK HOUR
STUDY AREA TRAFFIC VOLUMES**

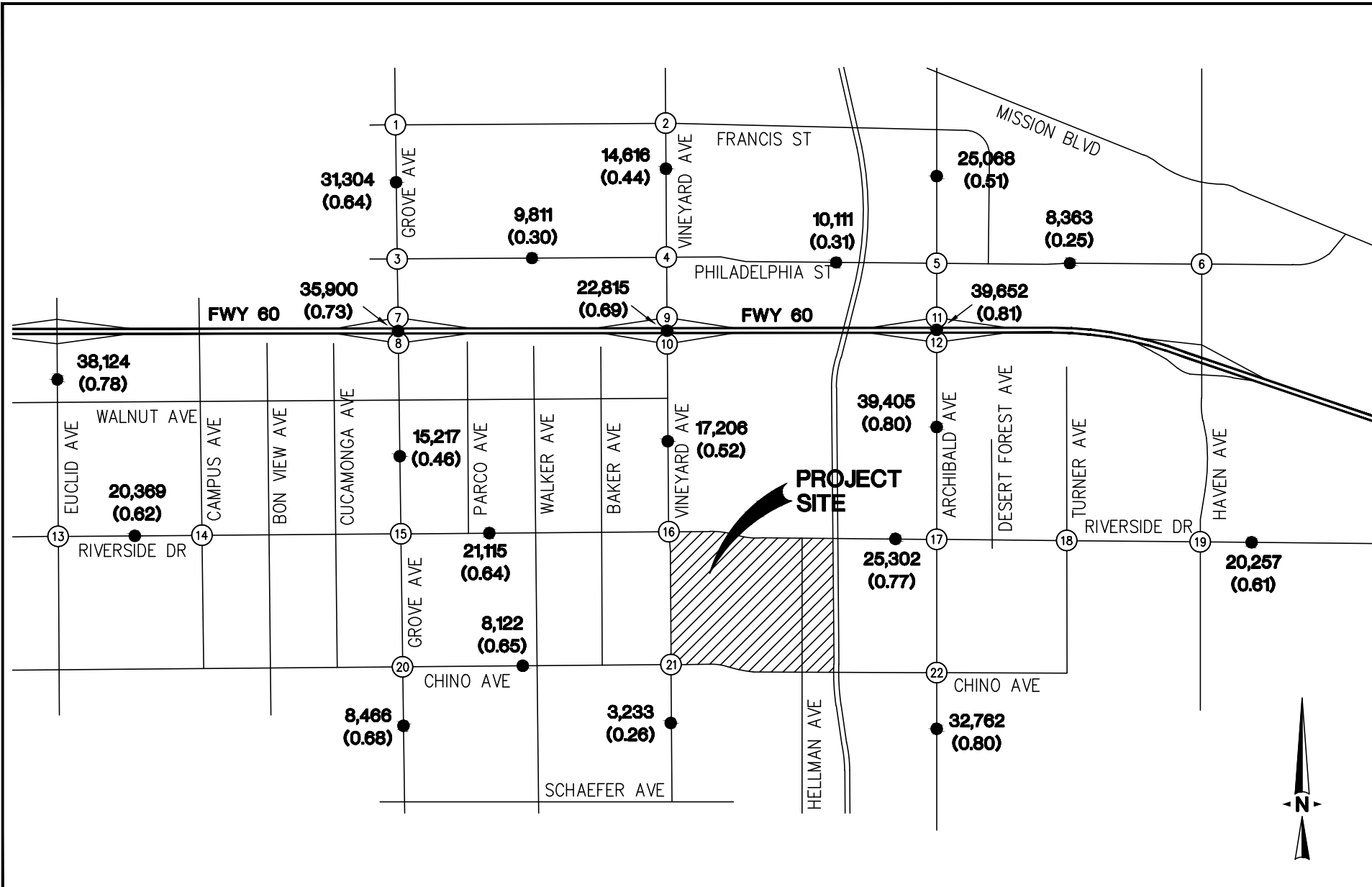

PREPARED BY:



**ARMSTRONG RANCH
TRAFFIC IMPACT STUDY
ONTARIO, CA**

**FIGURE 13
PHASE 3 BASELINE 2021 WEEKDAY
24-HOUR VOLUMES AND V/C RATIOS**

TABLE 1A
Level of Service Descriptions
For Signalized Intersections



Level of Service	Traffic Flow Description	Stopped Delay Per Vehicle (SEC)
A	Operations with delay less than or equal to 5.0 sec per vehicle; signal progression extremely favorable and/or short cycle lengths; most vehicles do not stop	<u>< 10.0</u>
B	Operations with delay in the range of 5.1 to 15.0 sec per vehicle; good progression and/or short cycle lengths; higher levels of average delay; more vehicle stops than LOS A	10.01 to 20.00
C	Operations with delay in the range of 15.1 to 25.0 sec per vehicle; fair progression and/or longer cycle lengths; significant number of vehicles stopping; cycle failures may begin to appear	20.01 to 35.00
D	Operations with delay in the range of 25.1 to 40.0 sec per vehicle; noticeable congestion; unfavorable progression; long cycle lengths, or high v/c ratios; many vehicles stop and portion of vehicles not stopping declines; noticeable individual cycle failures	35.01 to 55.00
E	Operations with delay in the range of 40.1 to 60.0 sec per vehicle; limit of acceptable delay; poor progression; long cycle lengths and high v/c ratios; frequent occurrences of individual cycle failures	55.01 to 80.00
F	Operations with delay in excess of 60.0 sec per vehicle; considered unacceptable driver delay; congestion; oversaturation; poor progression; long cycle lengths; high v/c ratios over 1.00; many individual cycle failures	> 80.01

TABLE 1B
Level of Service Descriptions
For Unsignalized Intersections



Level of Service	Traffic Flow Description	Worst Case Approach Delay Per Vehicle (SEC)
A	Operations with delay less than or equal to 10.0 sec per vehicle; most vehicles have a very short stop	≤10.0
B	Operations with delay in the range of 10.1 to 15.0 sec per vehicle; higher levels of delay, longer stops than LOS A	10.1 to 15.0
C	Operations with delay in the range of 15.1 to 25.0 sec per vehicle; significant levels of delay	15.1 to 25.0
D	Operations with delay in the range of 25.1 to 35.0 sec per vehicle; noticeable congestion; increased queue lengths; long delays	25.1 to 35.0
E	Operations with delay in the range of 35.1 to 50.0 sec per vehicle; limit of acceptable delay; very long delay; long queue lengths	35.1 to 50.0
F	Operations with delay in excess of 50.0 sec per vehicle; considered unacceptable driver delay; congestion; oversaturation; unacceptable queuing	> 50.0



TABLE 2
Existing Level of Service at Study Area Intersections

Signalized Intersection	Existing (2015)			
	AM Peak Hour		PM Peak Hour	
	Delay (sec.)	LOS	Delay (sec.)	LOS
1. Grove Ave/Francis St	17.5	B	19.6	B
2. Vineyard Ave/Francis St	15.5	B	17.6	B
3. Grove Ave/Philadelphia St	18.4	B	33.8	C
4. Vineyard Ave/Philadelphia St	17.6	B	23.1	C
5. Archibald Ave/Philadelphia St	14.8	B	26.9	C
6. Haven Ave/Philadelphia St	20.9	C	20.7	C
7. Grove Ave/Fwy 60 WB Ramp	19.5	B	37.0	D
8. Grove Ave/Fwy 60 EB Ramp	37.6	D	27.5	C
9. Vineyard Ave/Fwy 60 WB Ramp	17.2	B	18.9	B
10. Vineyard Ave/Fwy 60 EB Ramp	24.6	C	17.6	B
11. Archibald Ave/Fwy 60 WB Ramp	28.1	C	22.9	C
12. Archibald Ave/Fwy 60 EB Ramp	17.5	B	30.3	C
13. Euclid Ave/Riverside Dr	34.8	C	46.0	D
14. Campus Ave/Riverside Dr	18.9	B	16.0	B
15. Grove Ave/Riverside Dr	18.2	B	31.3	C
16. Vineyard Ave/Riverside Dr	18.0	B	53.0	D
17. Archibald Ave/Riverside Dr	36.2	D	44.9	D
18. Turner Ave/Riverside Dr	20.4	C	16.0	B
19. Haven Ave/Riverside Dr	48.3	D	34.3	C
22. Archibald Ave/Chino Ave	19.3	B	11.2	B
Unsignalized Intersection	Existing (2015)			
	AM Peak Hour		PM Peak Hour	
	Delay (sec.)	LOS	Delay (sec.)	LOS
20. Grove Ave/Chino Ave	15.6	C	56.6	F
21. Vineyard Ave/Chino Ave	8.9	A	9.1	A

V:\2065\active\2065000200\surmap\Eng\TechDocs\Reports\01 Traffic Study\02 Tables\REV. with CO-Watson Ind Added as Extra Cumul\Table 9 & 10- Baseline 2021 (elementary) proj



TABLE 3
Phase 1 Baseline 2017 Level of Service at Study Area Intersections

Signalized Intersection	Existing (2015)				2017 Baseline			
	AM Peak Hour		PM Peak Hour		AM Peak Hour		PM Peak Hour	
	Delay (sec.)	LOS	Delay (sec.)	LOS	Delay (sec.)	LOS	Delay (sec.)	LOS
1. Grove Ave/Francis St	17.5	B	19.6	B	17.3	B	19.1	B
2. Vineyard Ave/Francis St	15.5	B	17.6	B	14.1	B	17.1	B
3. Grove Ave/Philadelphia St	18.4	B	33.8	C	18.0	B	30.8	C
4. Vineyard Ave/Philadelphia St	17.6	B	23.1	C	17.2	B	23.3	C
5. Archibald Ave/Philadelphia St	14.8	B	26.9	C	14.5	B	31.9	C
6. Haven Ave/Philadelphia St	20.9	C	20.7	C	30.0	C	24.6	C
7. Grove Ave/Fwy 60 WB Ramp	19.5	B	37.0	D	18.2	B	32.4	C
8. Grove Ave/Fwy 60 EB Ramp	37.6	D	27.5	C	31.9	C	24.2	C
9. Vineyard Ave/Fwy 60 WB Ramp	17.2	B	18.9	B	17.5	B	21.6	C
10. Vineyard Ave/Fwy 60 EB Ramp	24.6	C	17.6	B	26.6	C	14.7	B
11. Archibald Ave/Fwy 60 WB Ramp	28.1	C	22.9	C	35.8	D	32.0	C
12. Archibald Ave/Fwy 60 EB Ramp	17.5	B	30.3	C	22.5	C	55.0	D
13. Euclid Ave/Riverside Dr	35.4	D	46.9	D	41.4	D	67.2	E
14. Campus Ave/Riverside Dr	18.9	B	16.0	B	19.4	B	17.0	B
15. Grove Ave/Riverside Dr	18.2	B	31.3	C	18.5	B	46.7	D
16. Vineyard Ave/Riverside Dr	18.0	B	53.0	D	45.4	D	137.4	F
17. Archibald Ave/Riverside Dr	36.2	D	44.9	D	49.3	D	93.0	F
18. Turner Ave/Riverside Dr	20.4	C	16.0	B	21.7	C	16.3	B
19. Haven Ave/Riverside Dr	48.3	D	34.3	C	453.0	F	526.4	F
22. Archibald Ave/Chino Ave	19.3	B	11.2	B	23.8	C	20.2	C
Unsignalized Intersection	Existing (2015)				2017 Baseline			
	AM Peak Hour		PM Peak Hour		AM Peak Hour		PM Peak Hour	
	Delay (sec.)	LOS	Delay (sec.)	LOS	Delay (sec.)	LOS	Delay (sec.)	LOS
20. Grove Ave/Chino Ave	15.6	C	56.6	F	OVERFLOW	F	OVERFLOW	F
21. Vineyard Ave/Chino Ave	8.9	A	9.1	A	299.0	F	92.8	F



TABLE 4
Phase 2 Baseline 2019 with Project Level of Service at Study Area Intersections

Signalized Intersection	Existing (2015)				2019 Baseline			
	AM Peak Hour		PM Peak Hour		AM Peak Hour		PM Peak Hour	
	Delay (sec.)	LOS	Delay (sec.)	LOS	Delay (sec.)	LOS	Delay (sec.)	LOS
1. Grove Ave/Francis St	17.5	B	19.6	B	17.4	B	19.3	B
2. Vineyard Ave/Francis St	15.5	B	17.6	B	14.1	B	17.3	B
3. Grove Ave/Philadelphia St	18.4	B	33.8	C	18.2	B	32.4	C
4. Vineyard Ave/Philadelphia St	17.6	B	23.1	C	17.4	B	23.9	C
5. Archibald Ave/Philadelphia St	14.8	B	26.9	C	14.6	B	34.8	C
6. Haven Ave/Philadelphia St	20.9	C	20.7	C	32.7	C	25.8	C
7. Grove Ave/Fwy 60 WB Ramp	19.5	B	37.0	D	18.7	B	34.7	C
8. Grove Ave/Fwy 60 EB Ramp	37.6	D	27.5	C	34.3	C	25.5	C
9. Vineyard Ave/Fwy 60 WB Ramp	17.2	B	18.9	B	17.6	B	23.1	C
10. Vineyard Ave/Fwy 60 EB Ramp	24.6	C	17.6	B	28.3	C	19.4	B
11. Archibald Ave/Fwy 60 WB Ramp	28.1	C	22.9	C	38.5	D	36.7	D
12. Archibald Ave/Fwy 60 EB Ramp	17.5	B	30.3	C	24.3	C	60.1	E
13. Euclid Ave/Riverside Dr	35.4	D	46.9	D	41.8	D	68.7	E
14. Campus Ave/Riverside Dr	18.9	B	16.0	B	19.8	B	17.6	B
15. Grove Ave/Riverside Dr	18.2	B	31.3	C	18.9	B	52.8	D
16. Vineyard Ave/Riverside Dr	18.0	B	53.0	D	47.7	D	139.3	F
17. Archibald Ave/Riverside Dr	36.2	D	44.9	D	53.0	D	98.8	F
18. Turner Ave/Riverside Dr	20.4	C	16.0	B	22.4	C	16.5	B
19. Haven Ave/Riverside Dr	48.3	D	34.3	C	458.0	F	526.2	F
22. Archibald Ave/Chino Ave	19.3	B	11.2	B	24.9	C	20.8	C
Unsignalized Intersection	Existing (2015)				2019 Baseline			
	AM Peak Hour		PM Peak Hour		AM Peak Hour		PM Peak Hour	
	Delay (sec.)	LOS	Delay (sec.)	LOS	Delay (sec.)	LOS	Delay (sec.)	LOS
20. Grove Ave/Chino Ave	15.6	C	56.6	F	OVERFLOW	F	OVERFLOW	F
21. Vineyard Ave/Chino Ave	8.9	A	9.1	A	300.2	F	94.9	F

V:\2065\active\2065000200\surmap\Eng\TechDocs\Reports\01 Traffic Study\02 Tables\REV. with CO-Watson Ind Added as Extra Cumul\Table 9 & 10- Baseline 2021 (elementary) project LOS .xls\TABLE 9



TABLE 5
Phase 3 Baseline 2021 Level of Service at Study Area Intersections

Signalized Intersection	Existing (2015)				2021 Baseline			
	AM Peak Hour		PM Peak Hour		AM Peak Hour		PM Peak Hour	
	Delay (sec.)	LOS	Delay (sec.)	LOS	Delay (sec.)	LOS	Delay (sec.)	LOS
1. Grove Ave/Francis St	17.5	B	19.6	B	17.5	B	19.6	B
2. Vineyard Ave/Francis St	15.5	B	17.6	B	14.2	B	17.3	B
3. Grove Ave/Philadelphia St	18.4	B	33.8	C	18.4	B	33.8	C
4. Vineyard Ave/Philadelphia St	17.6	B	23.1	C	17.5	B	24.4	C
5. Archibald Ave/Philadelphia St	14.8	B	26.9	C	14.6	B	34.4	C
6. Haven Ave/Philadelphia St	20.9	C	20.7	C	35.6	D	25.6	C
7. Grove Ave/Fwy 60 WB Ramp	19.5	B	37.0	D	19.4	B	37.0	D
8. Grove Ave/Fwy 60 EB Ramp	37.6	D	27.5	C	37.2	D	27.3	C
9. Vineyard Ave/Fwy 60 WB Ramp	17.2	B	18.9	B	18.1	B	24.9	C
10. Vineyard Ave/Fwy 60 EB Ramp	24.6	C	17.6	B	30.4	C	20.2	C
11. Archibald Ave/Fwy 60 WB Ramp	28.1	C	22.9	C	41.3	D	39.8	D
12. Archibald Ave/Fwy 60 EB Ramp	17.5	B	30.3	C	25.8	C	63.6	E
13. Euclid Ave/Riverside Dr	35.4	D	46.9	D	47.2	D	72.4	E
14. Campus Ave/Riverside Dr	18.9	B	16.0	B	20.3	C	18.1	B
15. Grove Ave/Riverside Dr	18.2	B	31.3	C	19.3	B	45.0	D
16. Vineyard Ave/Riverside Dr	18.0	B	53.0	D	49.5	D	131.4	F
17. Archibald Ave/Riverside Dr	36.2	D	44.9	D	55.9	E	104.8	F
18. Turner Ave/Riverside Dr	20.4	C	16.0	B	23.1	C	16.8	B
19. Haven Ave/Riverside Dr	48.3	D	34.3	C	463.8	F	528.7	F
22. Archibald Ave/Chino Ave	19.3	B	11.2	B	25.8	C	21.2	C
Unsignalized Intersection	Existing (2015)				2021 Baseline			
	AM Peak Hour		PM Peak Hour		AM Peak Hour		PM Peak Hour	
	Delay (sec.)	LOS	Delay (sec.)	LOS	Delay (sec.)	LOS	Delay (sec.)	LOS
20. Grove Ave/Chino Ave	15.6	C	56.6	F	OVERFLOW	F	OVERFLOW	F
21. Vineyard Ave/Chino Ave	8.9	A	9.1	A	302.6	F	96.5	F

V:\2065\active\2065000200\surmap\Eng\TechDocs\Reports\01 Traffic Study\02 Tables\REV. with CO-Watson Ind Added as Extra Cumul\Table 9 & 10- Baseline 2021 (elementary) project LOS .xls\TABLE 9

A.4 Existing 2015 Traffic Conditions

Table 2 shows that all existing study area intersections except one are operating at acceptable level of service (LOS) E or higher during am and pm peak hours with existing 2015 traffic volumes and improvements. All signalized study area intersections are currently operating at Level of Service D or better during peak hours. Only the stop-controlled Grove Avenue and Chino Avenue intersection is predicted to operate at LOS F during the pm peak hour under existing conditions.

Figure 6 shows that study area roadway segments have volume-to-capacity (v/c) ratios of 0.90 or below indicating LOS D or better operation based on existing 24-hour volumes and improvements.

A.5 Phase 1 Baseline 2017 Traffic Conditions

Table 3 shows that for forecast Phase 1 Baseline 2017 conditions the following signalized intersections are predicted to operate at LOS F in at least one peak hour:

Intersection	Am Peak Hour		Pm Peak Hour	
	Delay (s)	LOS	Delay (s)	LOS
16. Vineyard Avenue/Riverside Drive	45.4	D	137.4	F
17. Archibald Avenue/Riverside Drive	49.3	D	90.0	F
19. Haven Avenue/Riverside Drive	453.0	F	526.4	F

The stop-controlled Grove Avenue/Chino Avenue intersection is predicted to have overflow LOS F conditions in both the am and pm peak hours and the Vineyard Avenue/Chino Avenue stop-controlled intersection is also predicted to have LOS F during both peak hours. Both of these stop-controlled intersections satisfy at least one peak hour delay traffic signal warrant under Phase 1 Baseline 2017 (without Armstrong Ranch) conditions, and therefore signalization of these intersections could be a potential mitigation.

Figure 9 shows that study area roadway segments have volume-to-capacity ratios of 0.90 or below indicating LOS D or better operation based on Baseline 2017 24-hour volumes.

A.6 Phase 2 Baseline 2019 Traffic Conditions

Table 4 shows that for forecast Phase 2 Baseline 2019 conditions the same three (3) signalized intersections as identified for Baseline 2017 conditions are predicted to operate at LOS F in at least one peak hour:

Intersection	Am Peak Hour		Pm Peak Hour	
	Delay (s)	LOS	Delay (s)	LOS
16. Vineyard Avenue/Riverside Drive	47.7	D	139.3	F
17. Archibald Avenue/Riverside Drive	53.0	D	98.8	F
19. Haven Avenue/Riverside Drive	458.0	F	526.2	F

The stop-controlled Grove Avenue/Chino Avenue intersection is predicted to remain at overflow LOS F conditions in both the am and pm peak hours and the Vineyard Avenue/Chino Avenue stop-controlled intersection is predicted to continue operation at LOS F during both peak hours.

Figure 11 shows that study area roadway segments will continue to have volume-to-capacity ratios of 0.90 or below indicating LOS D or better operation based on Baseline 2019 24-hour volumes.

A.7 Phase 3 Baseline 2021 Traffic Conditions

Table 5 shows that for forecast Phase 3 Baseline 2021 conditions the same three (3) signalized intersections as identified for Baseline 2017 and 2019 conditions are predicted to remain operating at LOS F in at least one peak hour:

Intersection	Am Peak Hour		Pm Peak Hour	
	Delay (s)	LOS	Delay (s)	LOS
16. Vineyard Avenue/Riverside Drive	49.5	D	131.4	F
17. Archibald Avenue/Riverside Drive	55.9	E	104.8	F
19. Haven Avenue/Riverside Drive	463.8	F	528.7	F

The stop-controlled Grove Avenue/Chino Avenue intersection is predicted to remain at overflow LOS F conditions in both the am and pm peak hours and the Vineyard Avenue/Chino Avenue stop-controlled intersection is predicted to continue operation at LOS F during both peak hours.

Figure 13 shows that study area roadway segments will continue to have v/c ratios of 0.90 or below indicating LOS D or better operation based on Baseline 2021 24-hour volumes.

The decline in LOS at the intersections identified above for future 2017, 2019, and 2021 Baseline conditions can be attributed to the traffic generated by the other cumulative development projects included in this study. However, the Baseline scenarios analyzed and discussed above do not include any improvements to the existing circulation network. For the purpose of this study, however, all deficient study area intersections and roadway segments that occur with Armstrong Ranch project conditions will be identified together with appropriate mitigation measures and an Armstrong Ranch Project fair share contribution (percentage) toward implementation.

A.8 SR-60 Freeway Mainline Analysis with Existing Peak Hour Volumes

Figure 14 provides a summary of mainline LOS analysis for the SR-60 Freeway with existing peak hour volumes using the 2010 Highway Capacity Manual method for basic freeway segments. This figure shows that all SR-60 study segments are operating at LOS D or C with existing peak volumes. The LOS calculations are included in the appendices.

AM PEAK HOUR

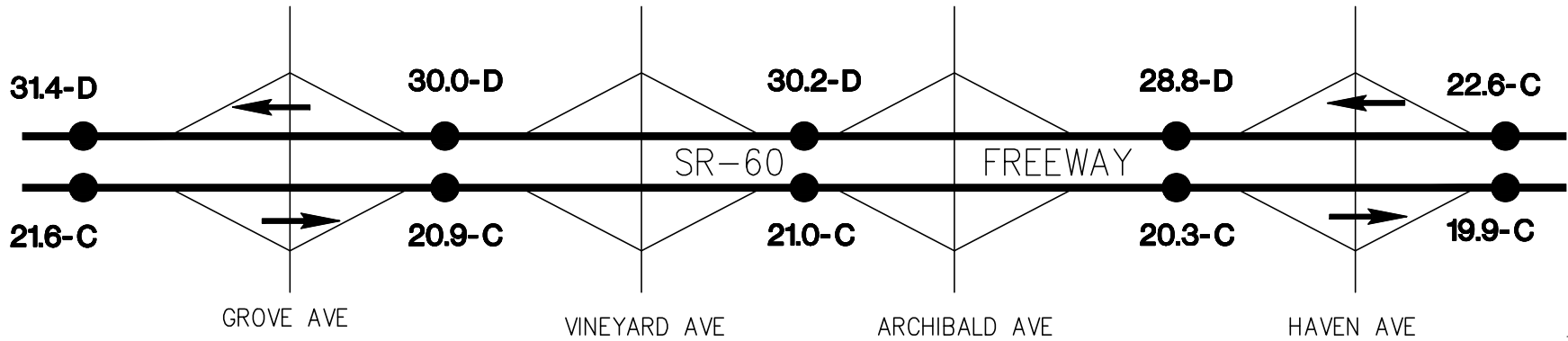

PM PEAK HOUR

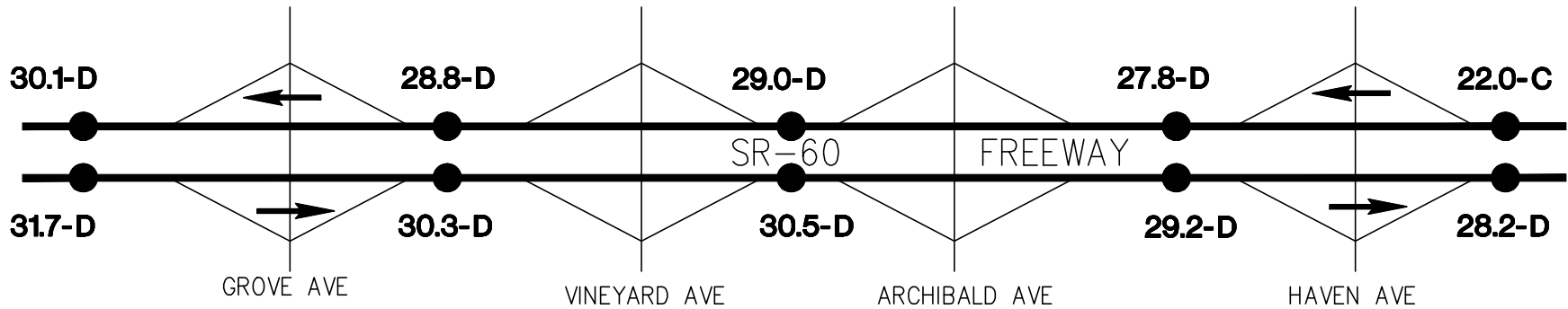

17.2 - PASSENGER CARS PER MILE PER LANE (PCPMPL)
 C - LOS

PREPARED BY:



**ARMSTRONG RANCH
 TRAFFIC IMPACT STUDY
 ONTARIO, CA**

**FIGURE 14
 EXISTING 2015 SR-60 MAINLINE
 LEVEL OF SERVICE (LOS)**

SECTION III **PROJECTED FUTURE TRAFFIC****A. TRIP GENERATION**

Trip generation of the proposed Armstrong Ranch development is shown on Table 6 by phase. Each Project phase analyzed in this study, Phase 1 (2017), Phase 2 (2019), and Phase 3 (2021), is considered to complete two Planning Areas, PA 1 and PA 2, PA 3 and PA 4, and PA 5 and PA 6, respectively. Trip generation rates used to forecast traffic volumes produced by the project are identified by the Institute of Transportation Engineers (ITE), in *Trip Generation*, 9th Edition. The forecast traffic generations shown on Table 6 are Phase 3 (2021) build-out volumes with and without an elementary school on the site. The total number of single-family dwelling units without the school is 994 and with the 1,000-student elementary school the total number of dwelling units is reduced by 50 to 944. Analysis of each Project phase was based on cumulative trip totals with completion of the current phase.

A.1 Project Phase 3 Build-out (completion 2021) without Elementary School

At build-out, anticipated for completion in 2021, the proposed project is estimated to generate an average of 9,463 vehicle trips ends per weekday based on development of a total of 994 single-family dwelling units. The forecast peak hour traffic generation of the project is 186 inbound and 560 outbound vehicle trips in the am peak hour and 626 inbound and 368 outbound trips in the pm peak hour.

A.2 Project Phase 3 Build-out (completion 2021) with Elementary School

With an elementary school and at completion of Phase 3 in 2021, the proposed project is estimated to generate an average of 9,503 vehicle trips ends per weekday based on development of a total of 944 single-family dwelling units and a 1,000-student elementary school. The forecast peak hour traffic generation of the project is 276 inbound and 612 outbound vehicle trips in the am peak hour and 624 inbound and 380 outbound trips in the pm peak hour.

A.3 Project Trip Distribution

Figure 15 shows the Project trip distribution. The trip distribution shown on Figure 15 was obtained from the San Bernardino Association of Governments (SANBAG) based on traffic forecasts performed for this study using the San Bernardino (County) Traffic Analysis Model (SBTAM). SBTAM model output used to determine the Project trip distribution is included in the appendices.

B. PROJECT TRAFFIC VOLUME FORECASTS

Using the cumulative trip generation for each project phase and the project trip distribution, study area peak hour intersection turning movement and daily roadway volumes were developed for each phase year.

B.1 Phase 1 (2017) Project Traffic Volume Forecasts

Figures 16A and 16B show Phase 1 project am and pm peak hour volumes at off-site study area intersections, respectively. These figures show the project peak hour turning movement volumes at off-site study area intersections and the total (two-way) project peak hour volumes on roadway links between intersections. Figure 17 shows Phase 1 project weekday daily traffic volumes within the study area. Figures 18A and 18B show Phase 1 am and pm peak hour on-site and access intersection volumes, respectively.

B.2 Phase 2 (2019) Project Traffic Volume Forecasts

Figures 19A and 19B show Phase 2 project am and pm peak hour volumes at off-site study area intersections, respectively. These figures show the project peak hour turning movement volumes at off-site study area intersections and the total (two-way) project peak hour volumes on roadway links between intersections. Figure 20 shows Phase 2 project weekday daily traffic volumes within the study area. Figures 21A and 21B show Phase 2 am and pm peak hour on-site and access intersection volumes, respectively.

B.3 Phase 3 (2021) Project Traffic Volume Forecasts (without Elementary School)

Figures 22A and 22B show Phase 3 (without school) project am and pm peak hour volumes at off-site study area intersections, respectively. These figures show the project peak hour turning movement volumes at off-site study area intersections and the total (two-way) project peak hour volumes on roadway links between intersections. Figure 23 shows Phase 3 project weekday daily traffic volumes within the study area. Figures 24A and 24B show Phase 3 am and pm peak hour on-site and access intersection volumes, respectively.

B.4 Phase 3 (2021) Project Traffic Volume Forecasts (with Elementary School)

Figures 25A and 25B show Phase 3 (with School) project am and pm peak hour volumes at off-site study area intersections, respectively. These figures show the project peak hour turning movement volumes at off-site study area intersections and the total (two-way) project peak hour volumes on roadway links between intersections. Figure 26 shows Phase 3 project weekday daily traffic volumes within the study area. Figures 27A and 27B show Phase 3 (with elementary school) am and pm peak hour on-site and access intersection volumes, respectively.



TABLE 6
Armstrong Ranch - Trip Generation Summary

Trip Generation Rates*

Scenario 1: Without Elementary School

Land Use	Unit	ITE Land		Daily Rate	AM Peak Hour Split			PM Peak Hour Split		
		Code	Quantity		Rate	In	Out	Rate	In	Out
1. Single Family Detached Housing	DU	210	994	9.52	0.75	25%	75%	1.00	63%	37%
- Phase 1 (PA 1 & 2)			350							
- Phase 2 (PA 3 & 4)			302							
- Phase 3 (PA 5 & 6)			342							

Scenario 2: With Elementary School

Land Use	Unit	ITE Land		Daily Rate	AM Peak Hour Split			PM Peak Hour Split		
		Code	Quantity		Rate	In	Out	Rate	In	Out
1. Single Family Detached Housing	DU	210	944	9.52	0.75	25%	75%	1.00	63%	37%
- Phase 1 (PA 1 & 2)			350							
- Phase 2 (PA 3 & 4)			302							
- Phase 3 (PA 5 & 6)			292							
2. Elementary School (Included in Phase 3)	STU	520	1,000	1.29	0.45	55%	45%	0.15	49%	51%

Project Trip Generation

Scenario 1: Without Elementary School

Land Use	Quantity	ADI	AM Peak Hour Volume			PM Peak Hour Volume		
			Total	In	Out	Total	In	Out
1. Single Family Detached Housing	994	9,463	746	186	560	994	626	368
- Phase 1 (PA 1 & 2)	350	3,332	263	66	197	350	221	129
- Phase 2 (PA 3 & 4)	302	2,875	227	57	170	302	190	112
- Phase 3 (PA 5 & 6)	342	3,256	256	63	193	342	215	127
Total		9,463	746	186	560	994	626	368

Scenario 2: With Elementary School

Land Use	Quantity	ADI	AM Peak Hour Volume			PM Peak Hour Volume		
			Total	In	Out	Total	In	Out
1. Single Family Detached Housing	944	8,987	708	177	531	944	595	349
- Phase 1 (PA 1 & 2)	350	3,332	263	66	197	350	221	129
- Phase 2 (PA 3 & 4)	302	2,875	227	57	170	302	190	112
- Phase 3 (PA 5 & 6)	292	2,780	218	54	164	292	184	108
2. Elementary School (External Students) Elem. School Included in Phase 3	1,000	516	180	99	81	60	29	31
Total		9,503	888	276	612	1,004	624	380

* Source: ITE Trip Generation Manual, 9th Edition

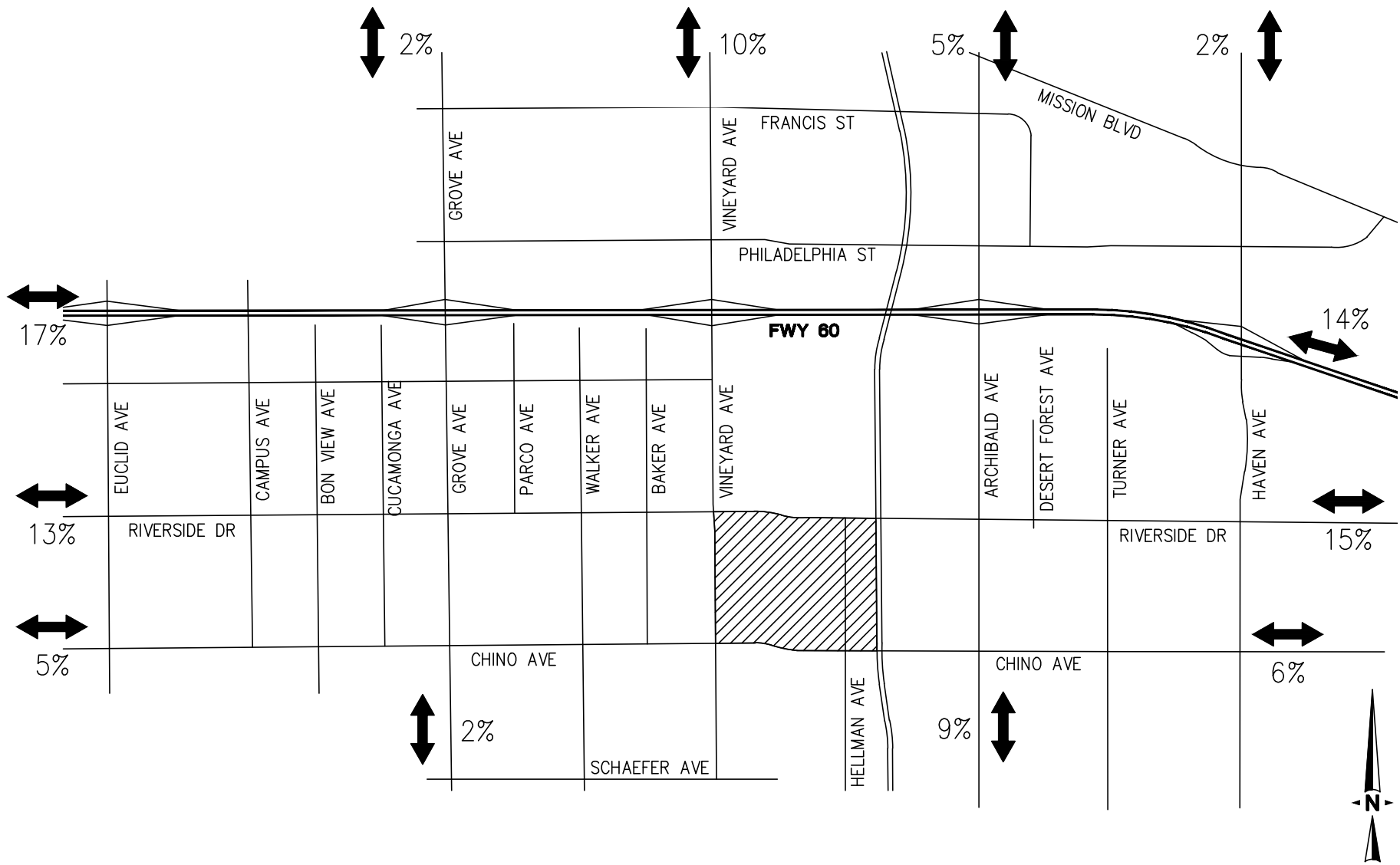

PREPARED BY:



**ARMSTRONG RANCH
TRAFFIC IMPACT STUDY
ONTARIO, CA**

**FIGURE 15
PROJECT TRIP DISTRIBUTION
SANBAG-SBTAM**

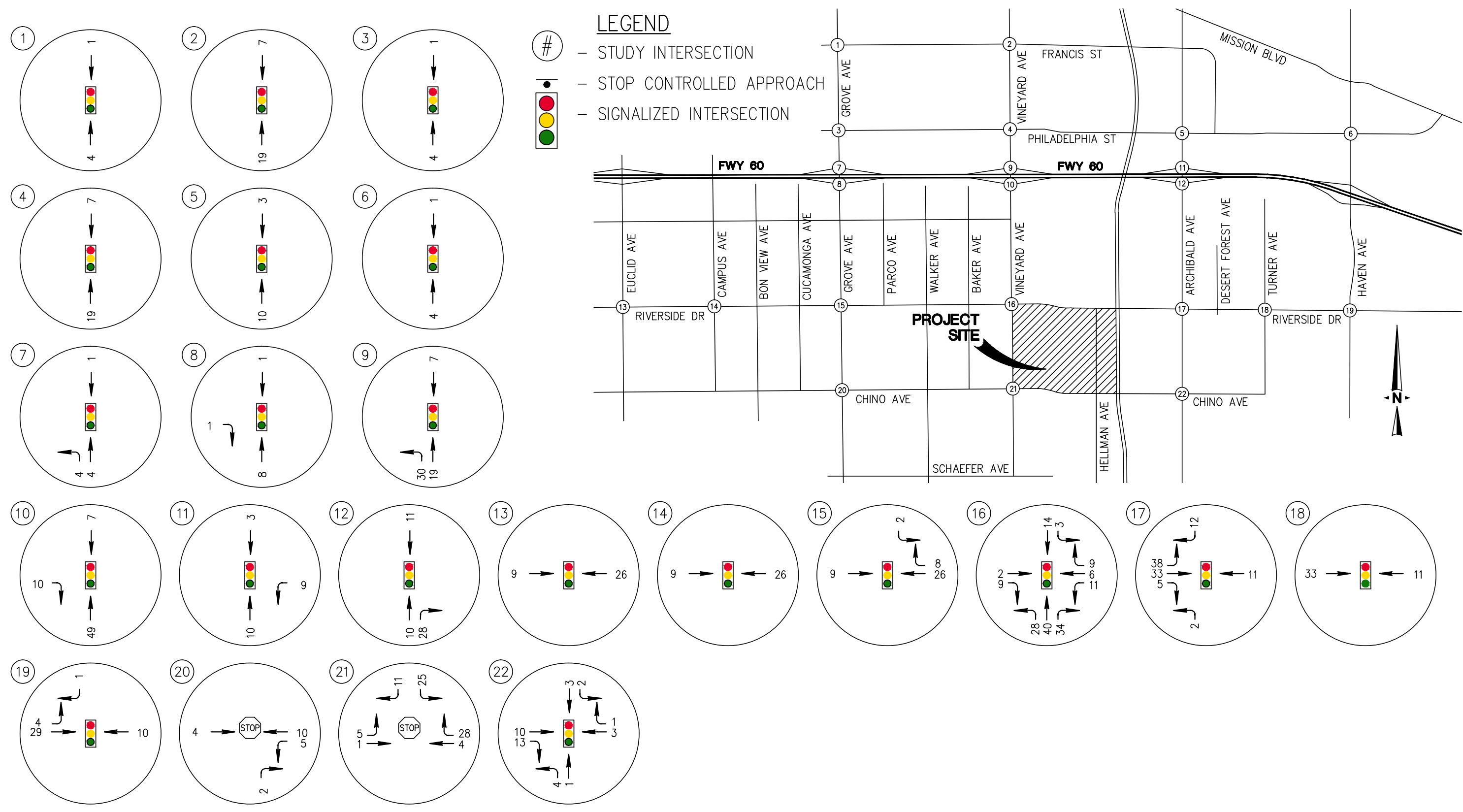

PREPARED BY:



**ARMSTRONG RANCH
TRAFFIC IMPACT STUDY
ONTARIO, CA**

**FIGURE 16A
PHASE 1 (2017) PROJECT AM PEAK HOUR
STUDY AREA TRAFFIC VOLUMES**

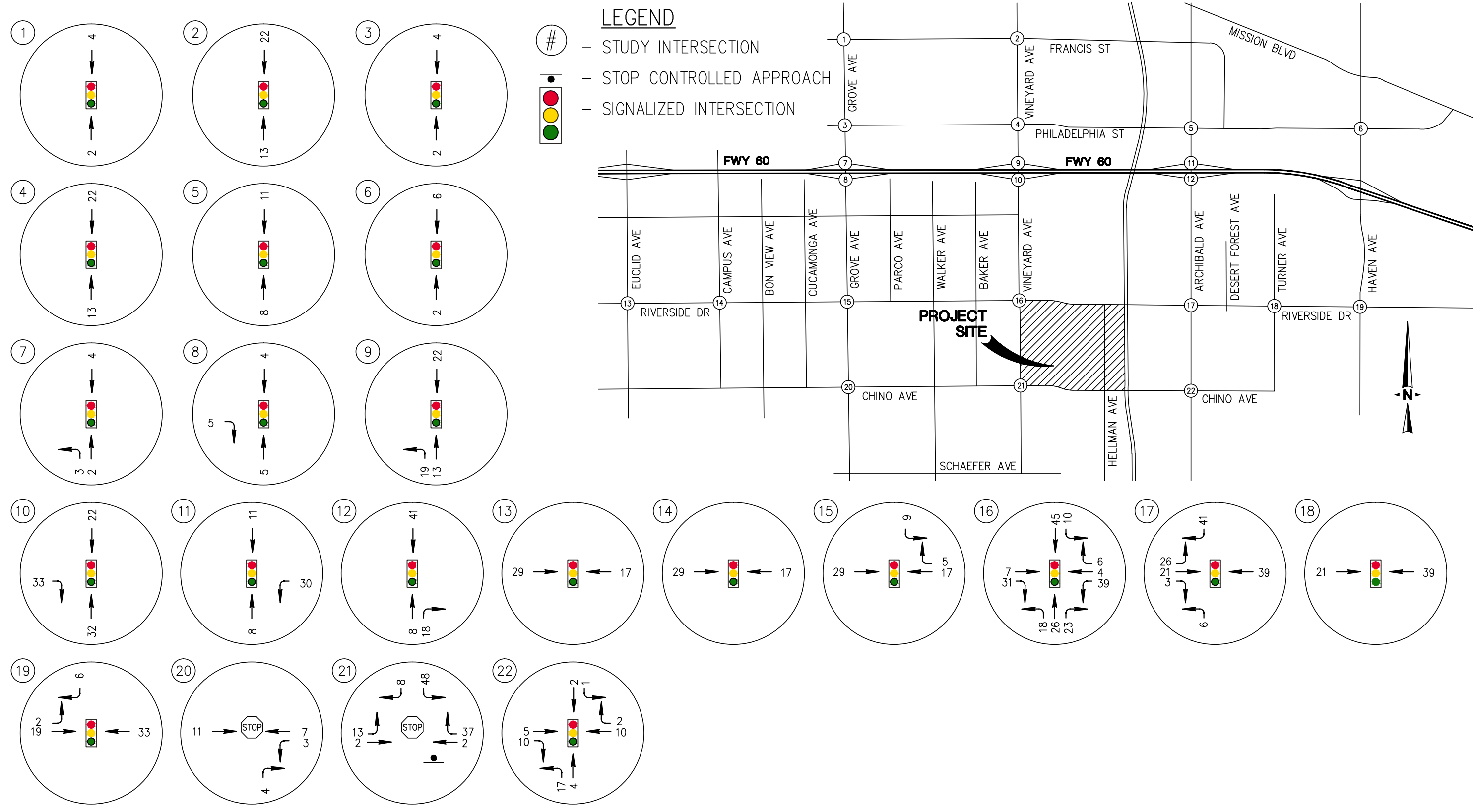

PREPARED BY:



**ARMSTRONG RANCH
TRAFFIC IMPACT STUDY
ONTARIO, CA**

**FIGURE 16B
PHASE 1 (2017) PROJECT PM PEAK HOUR
STUDY AREA TRAFFIC VOLUMES**

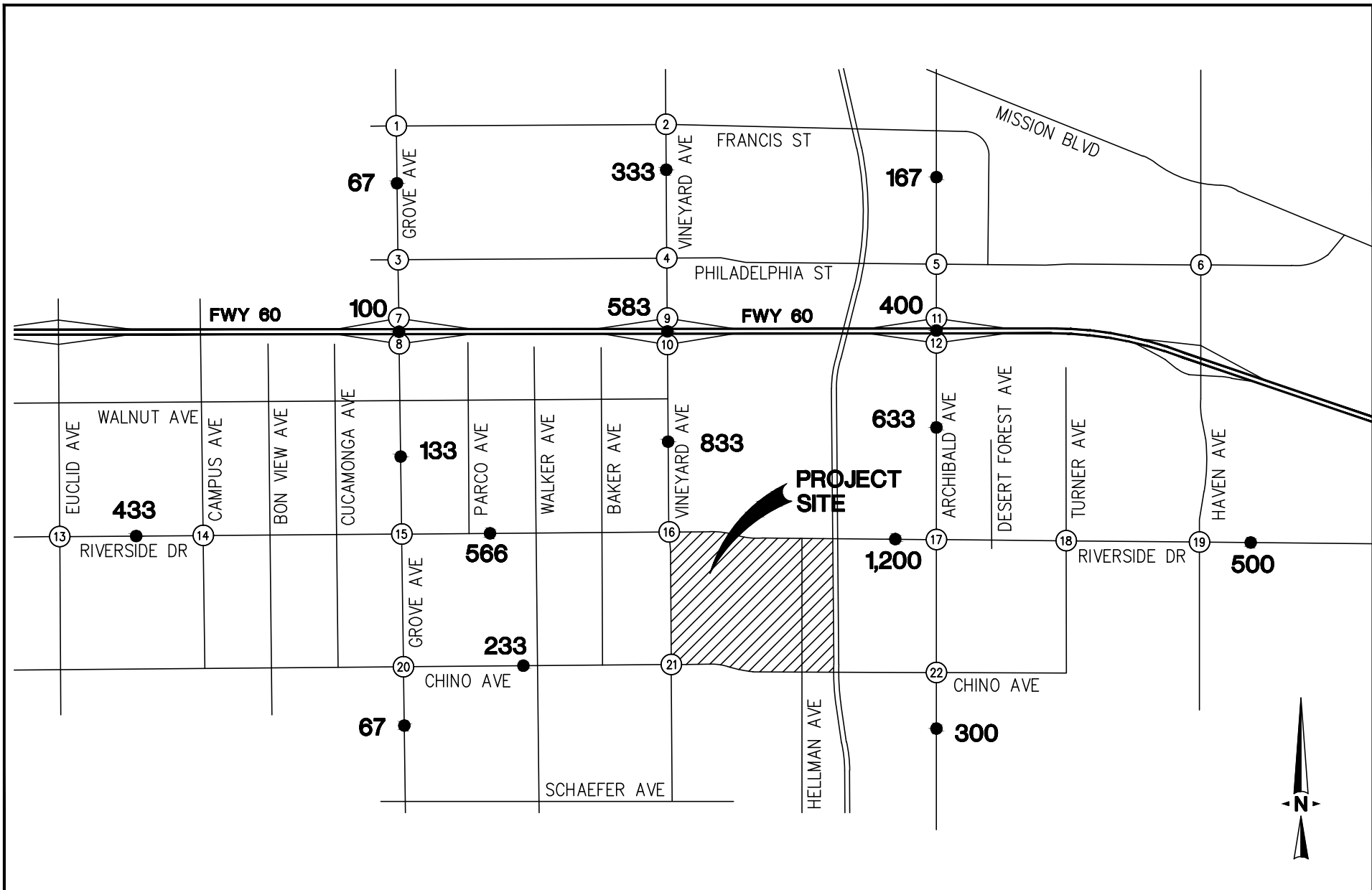

PREPARED BY:



**ARMSTRONG RANCH
TRAFFIC IMPACT STUDY
ONTARIO, CA**

**FIGURE 17
PHASE 1 (2017) PROJECT WEEKDAY
DAILY STUDY AREA TRAFFIC VOLUMES**

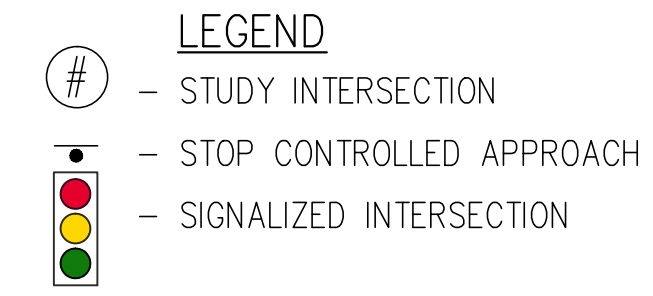
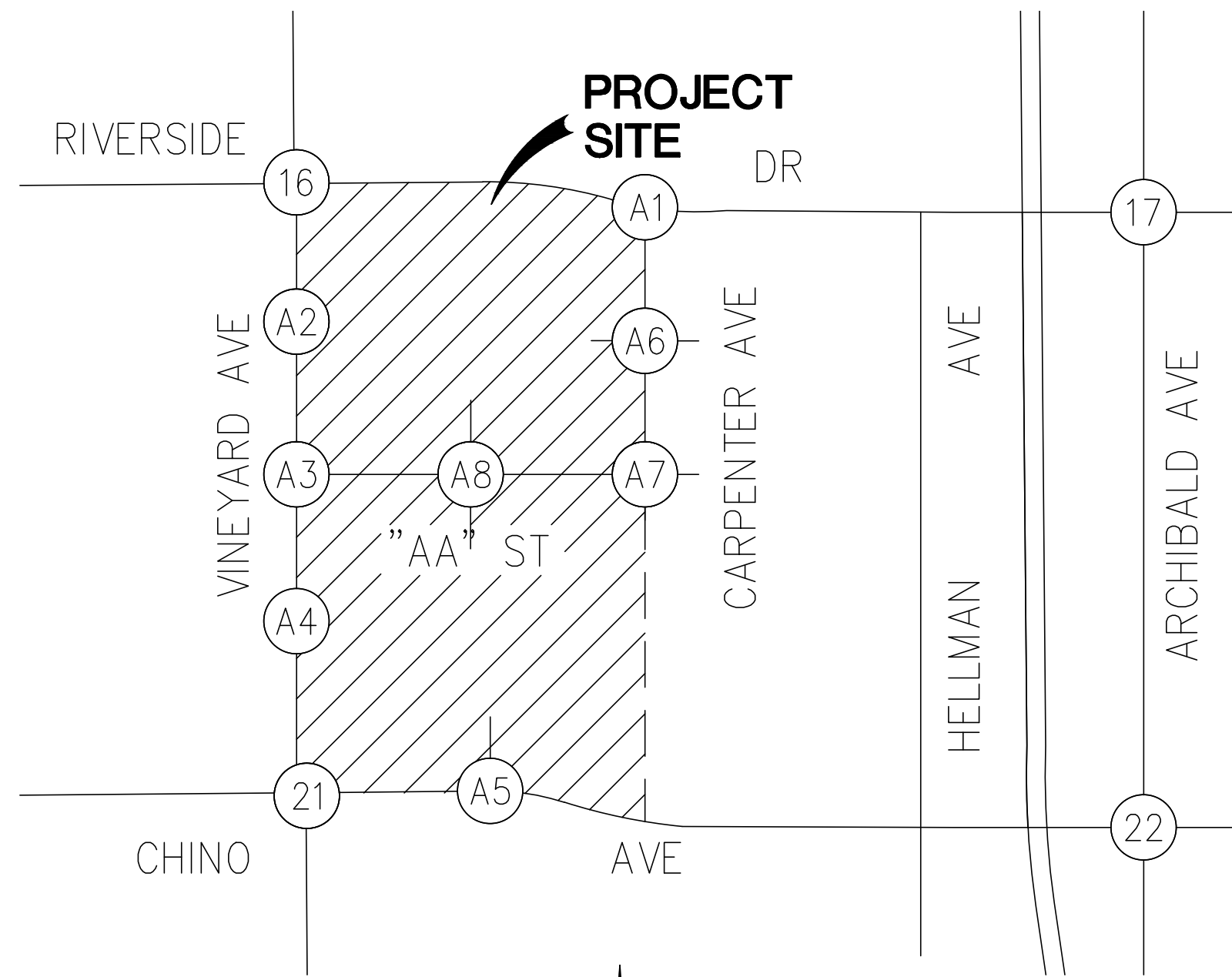
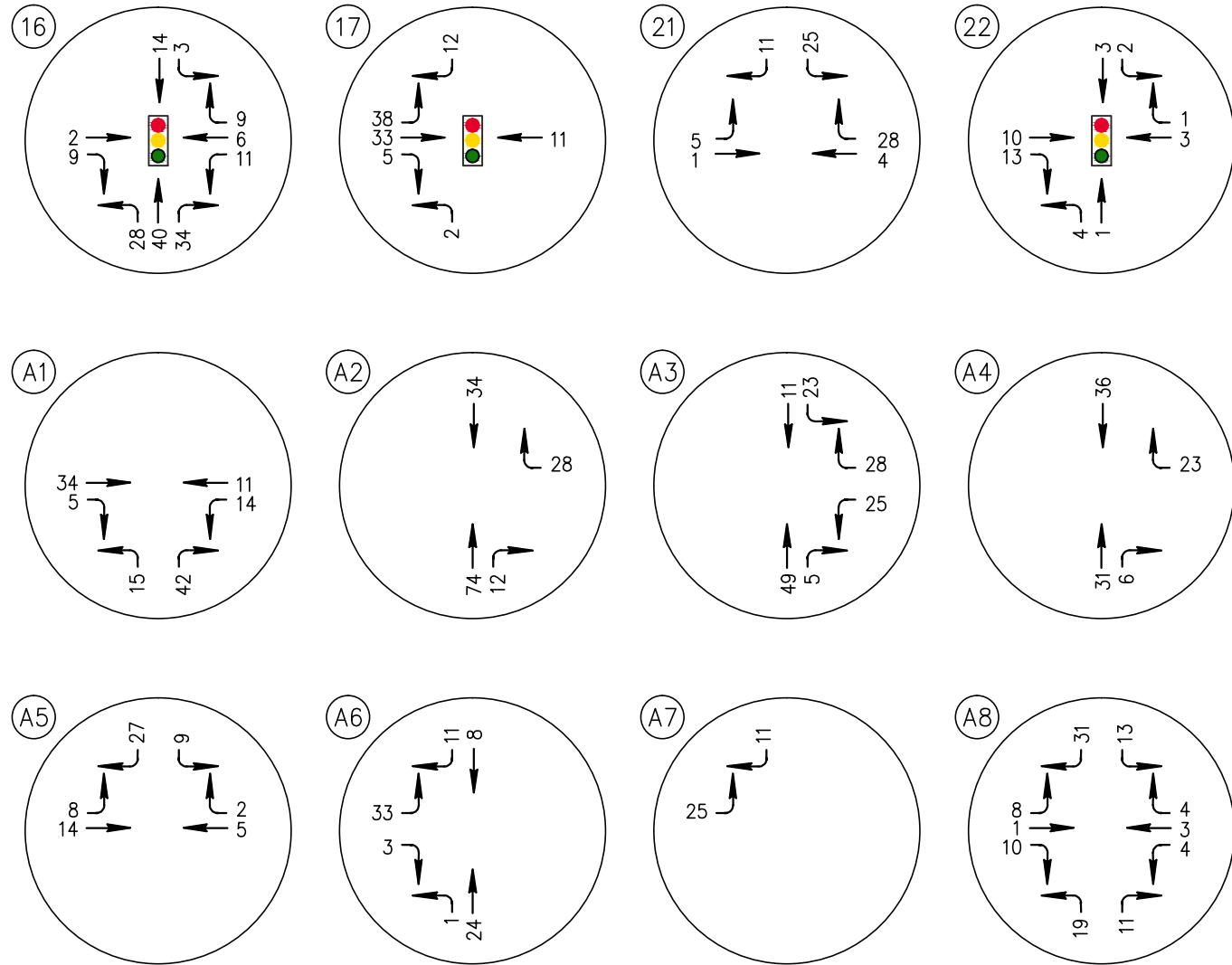

PREPARED BY:



**ARMSTRONG RANCH
TRAFFIC IMPACT STUDY
ONTARIO, CA**

**FIGURE 18A
PHASE 1 (2017) PROJECT AM PEAK HOUR
ACCESS AND ON-SITE INTERSECTION VOLUMES**

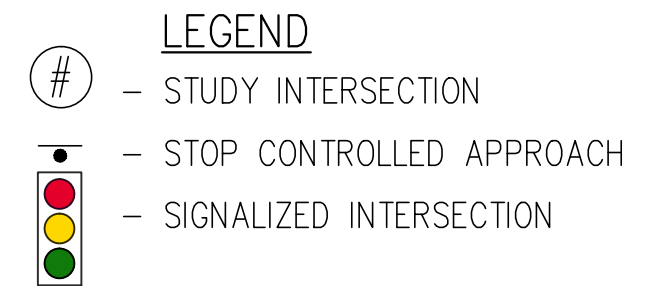
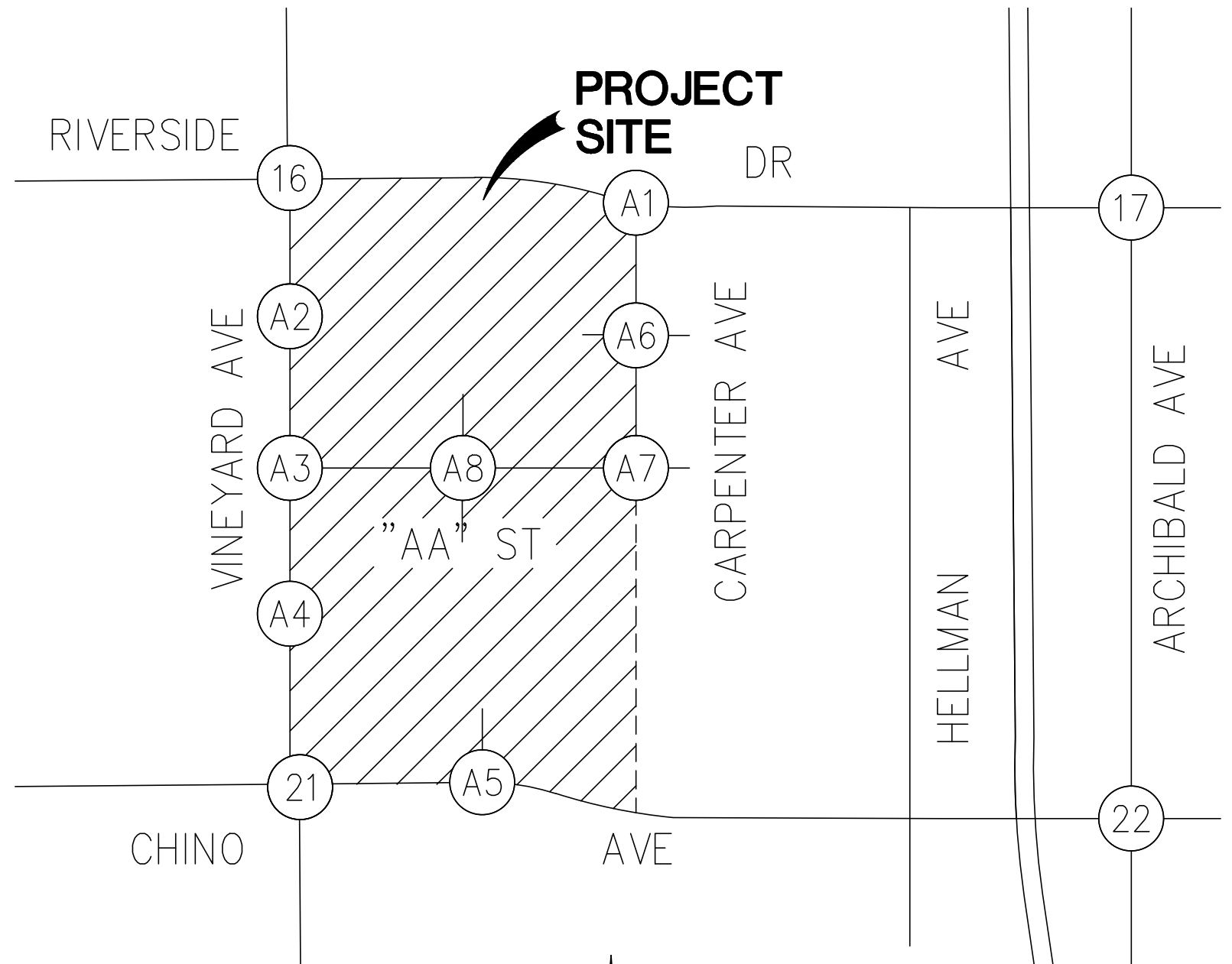
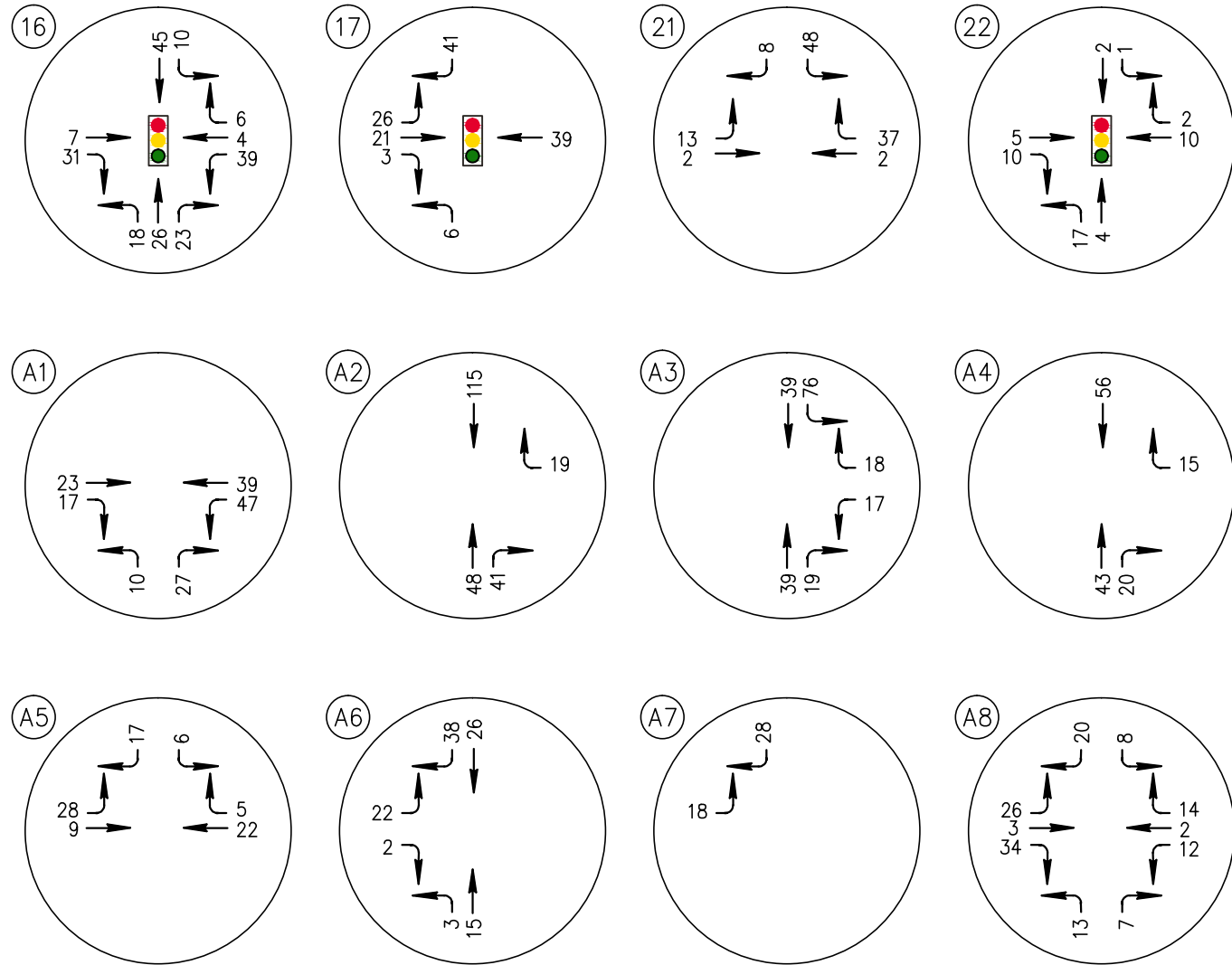

PREPARED BY:



**ARMSTRONG RANCH
TRAFFIC IMPACT STUDY
ONTARIO, CA**

**FIGURE 18B
PHASE 1 (2017) PROJECT PM PEAK HOUR
ACCESS AND ON-SITE INTERSECTION VOLUMES**

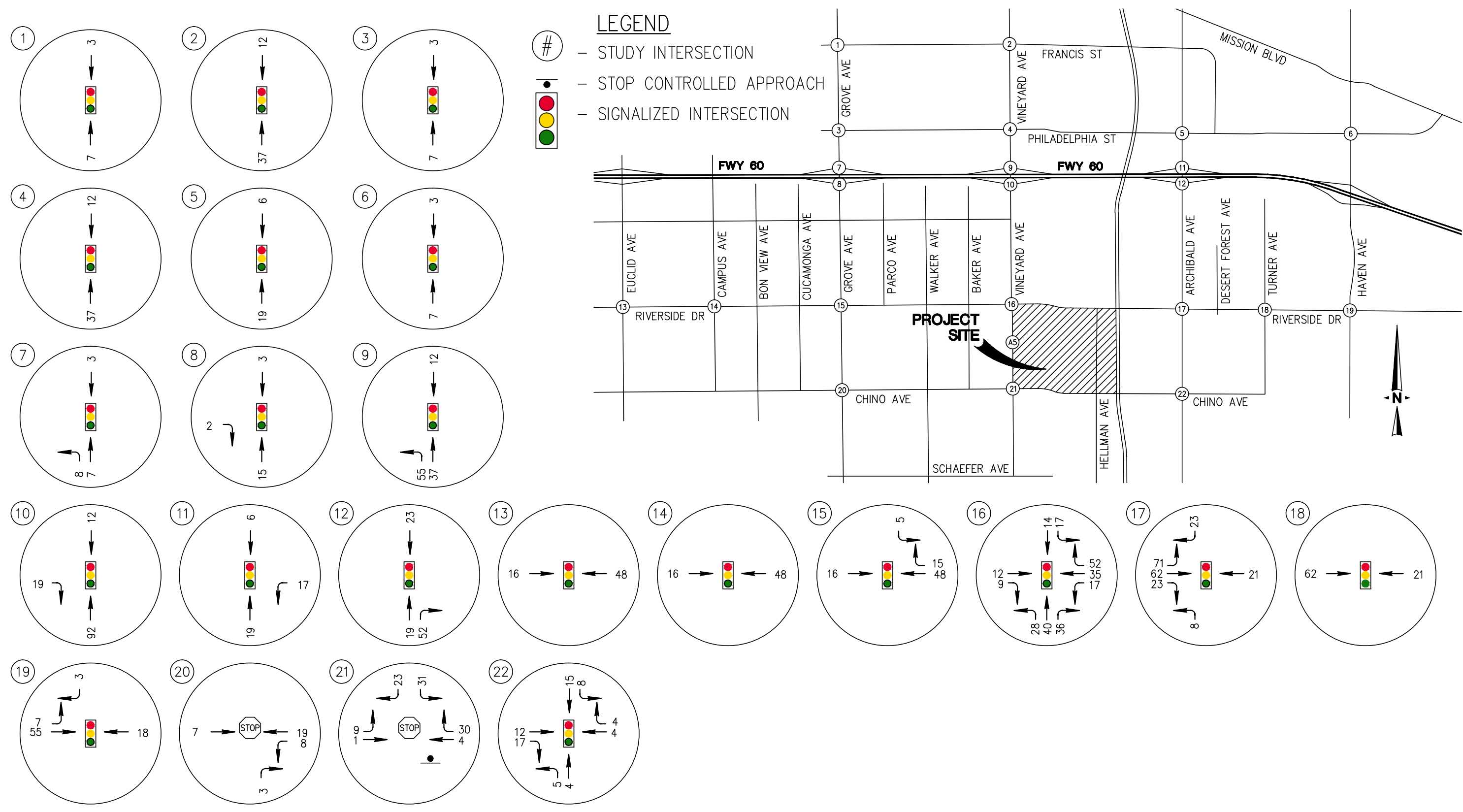

PREPARED BY:



**ARMSTRONG RANCH
TRAFFIC IMPACT STUDY
ONTARIO, CA**

**FIGURE 19A
PHASE 2 (2019) PROJECT AM PEAK HOUR
STUDY AREA TRAFFIC VOLUMES**

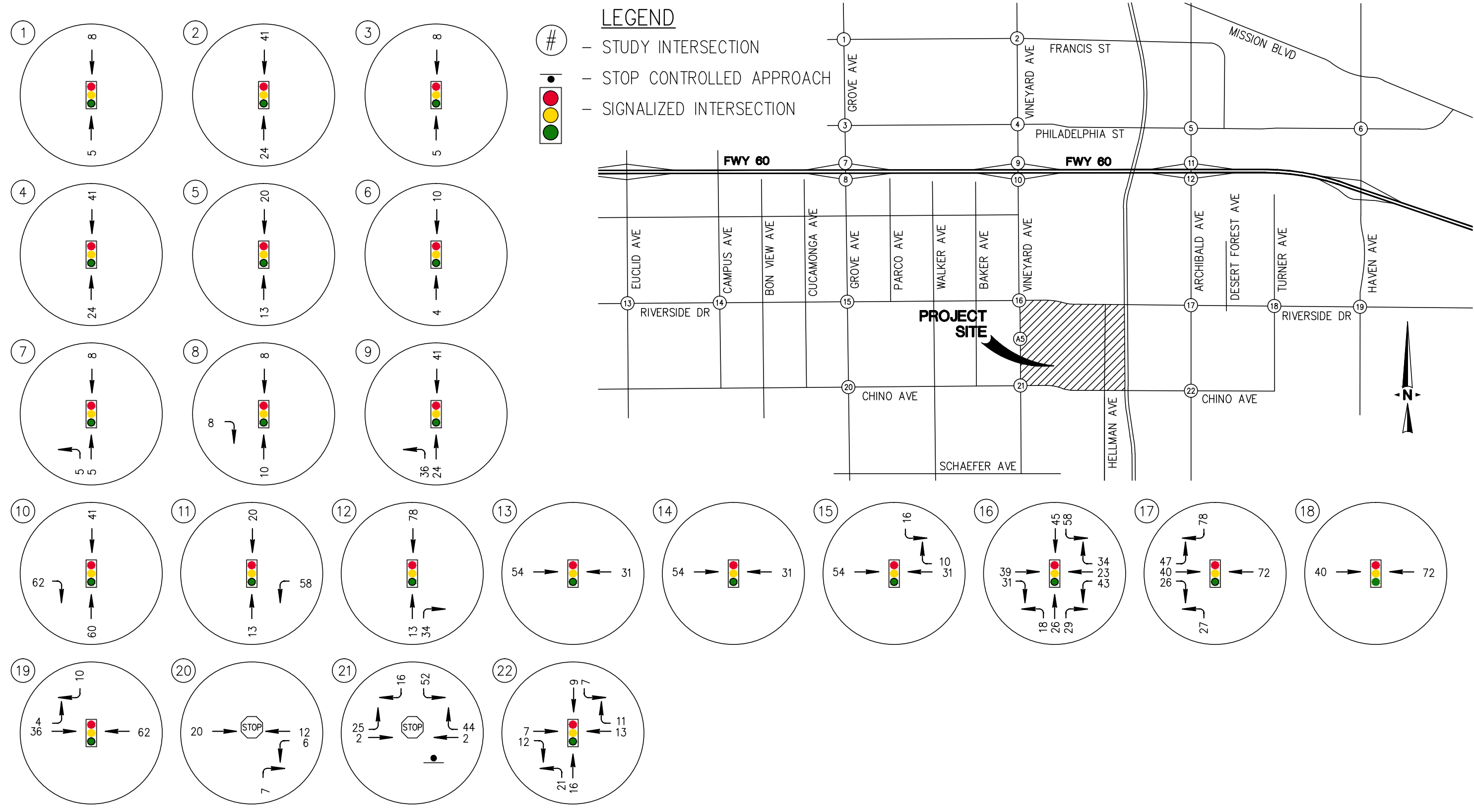

PREPARED BY:



**ARMSTRONG RANCH
TRAFFIC IMPACT STUDY
ONTARIO, CA**

**FIGURE 19B
PHASE 2 (2019) PROJECT PM PEAK HOUR
STUDY AREA TRAFFIC VOLUMES**

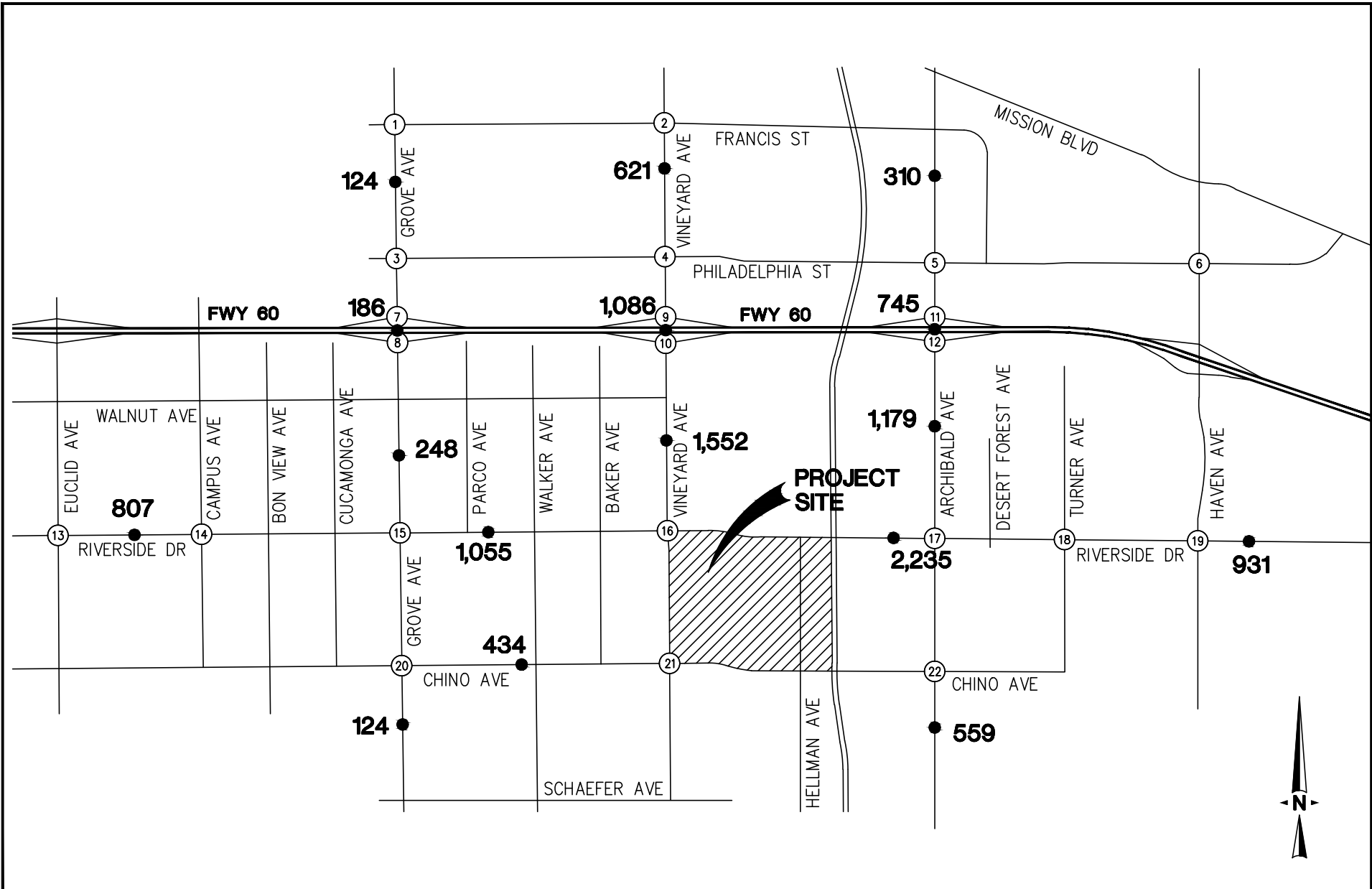

PREPARED BY:



**ARMSTRONG RANCH
TRAFFIC IMPACT STUDY
ONTARIO, CA**

**FIGURE 20
PHASE 2 (2019) PROJECT WEEKDAY
DAILY STUDY AREA TRAFFIC VOLUMES**

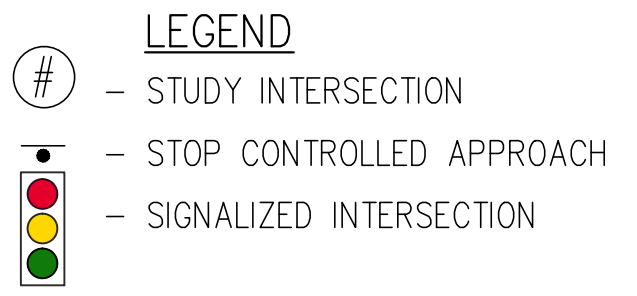
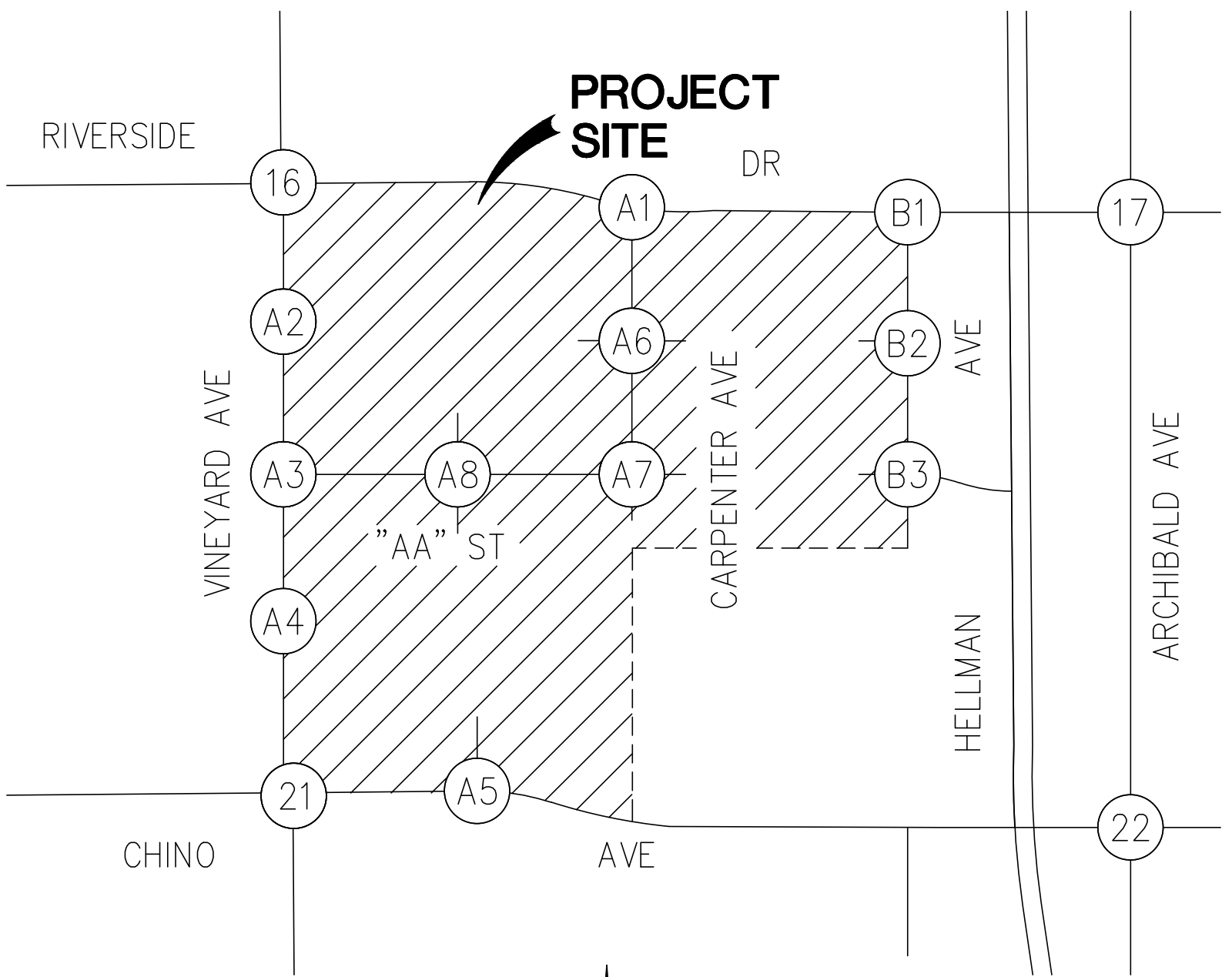
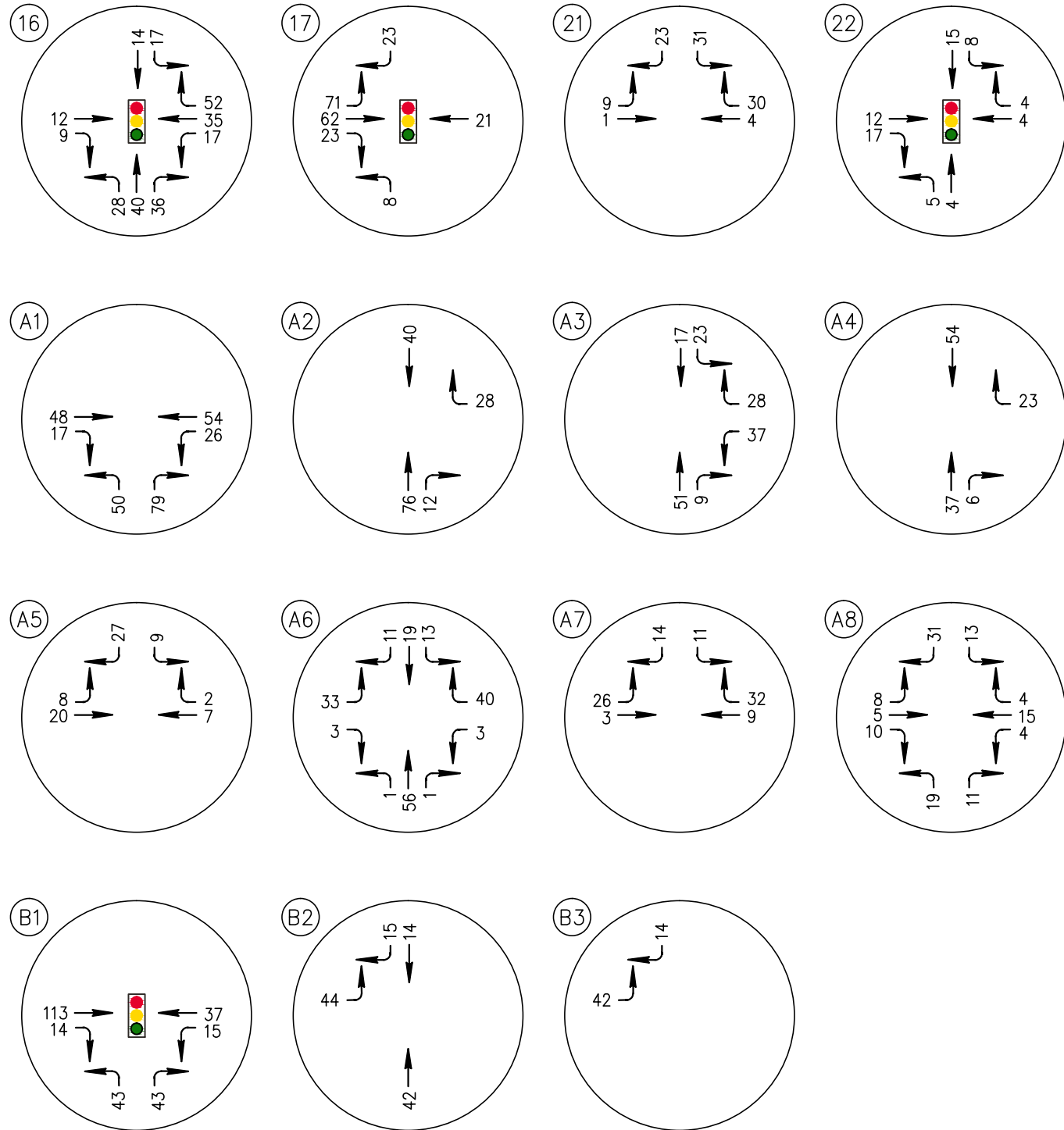

PREPARED BY:



**ARMSTRONG RANCH
TRAFFIC IMPACT STUDY
ONTARIO, CA**

**FIGURE 21A
PHASE 2 (2019) PROJECT AM PEAK HOUR
ACCESS AND ON-SITE INTERSECTION VOLUMES**

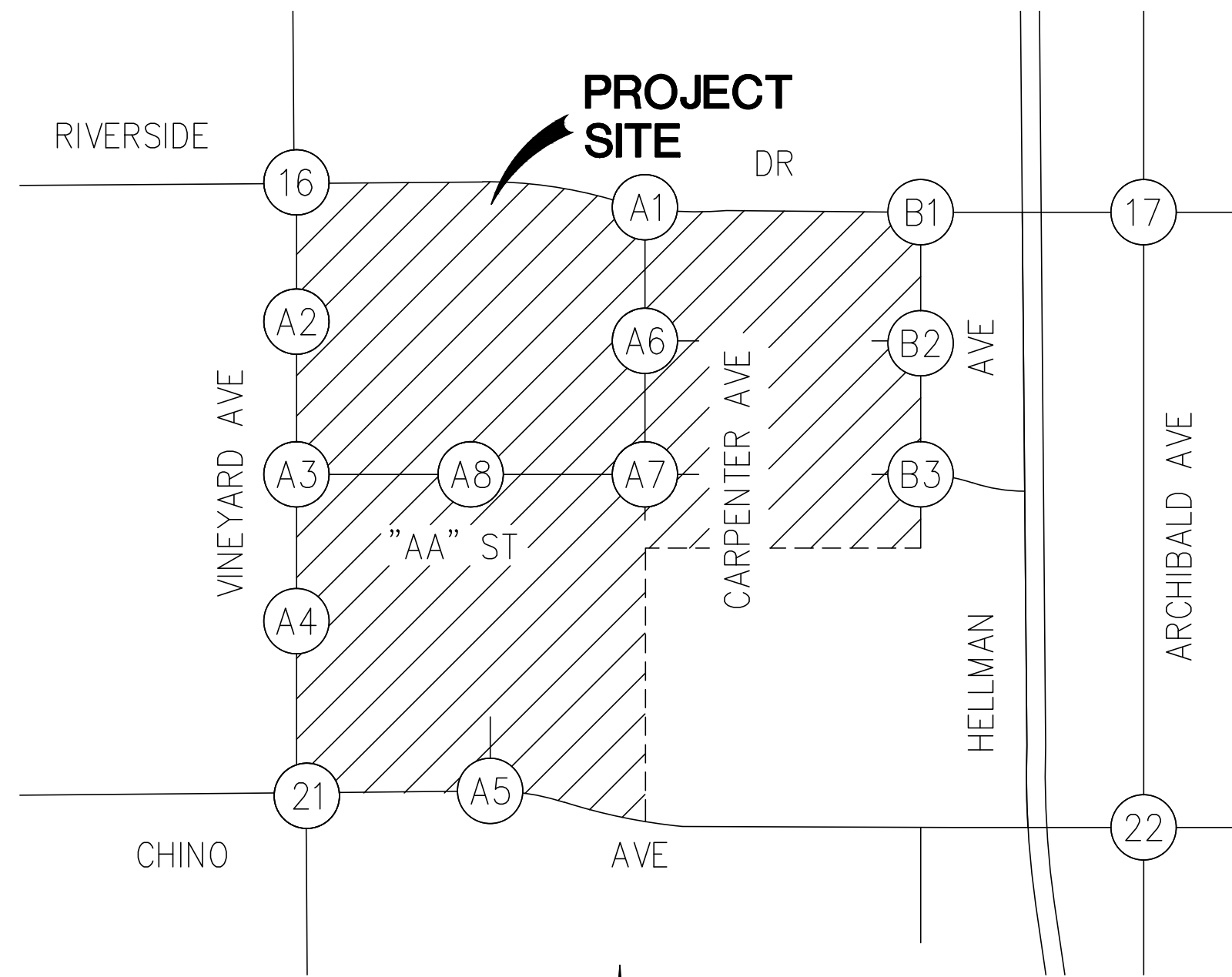
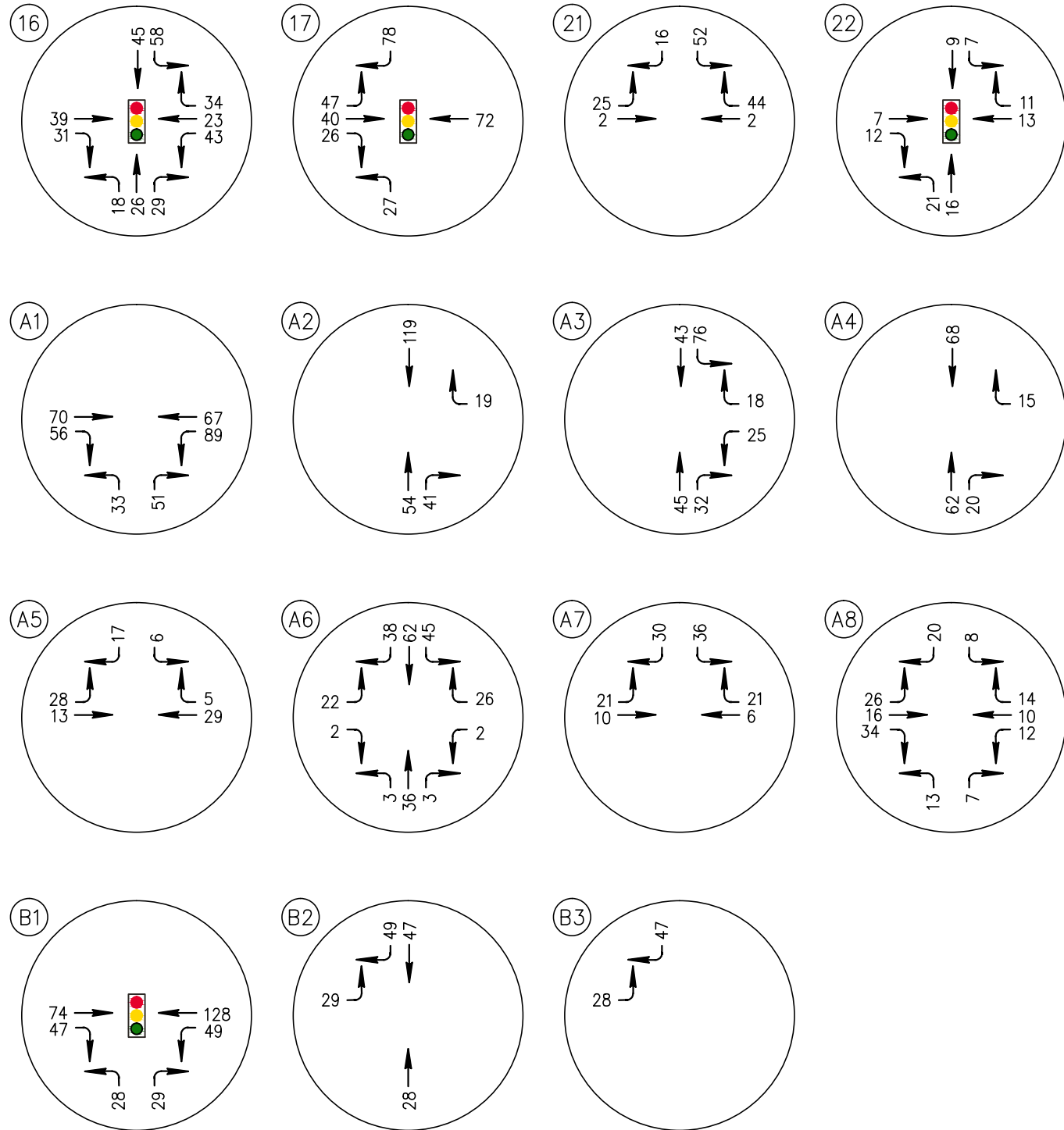

- LEGEND**
- # - STUDY INTERSECTION
 - - STOP CONTROLLED APPROACH
 - 🚦 - SIGNALIZED INTERSECTION

PREPARED BY:



**ARMSTRONG RANCH
TRAFFIC IMPACT STUDY
ONTARIO, CA**

**FIGURE 21B
PHASE 2 (2019) PROJECT PM PEAK HOUR
ACCESS AND ON-SITE INTERSECTION VOLUMES**

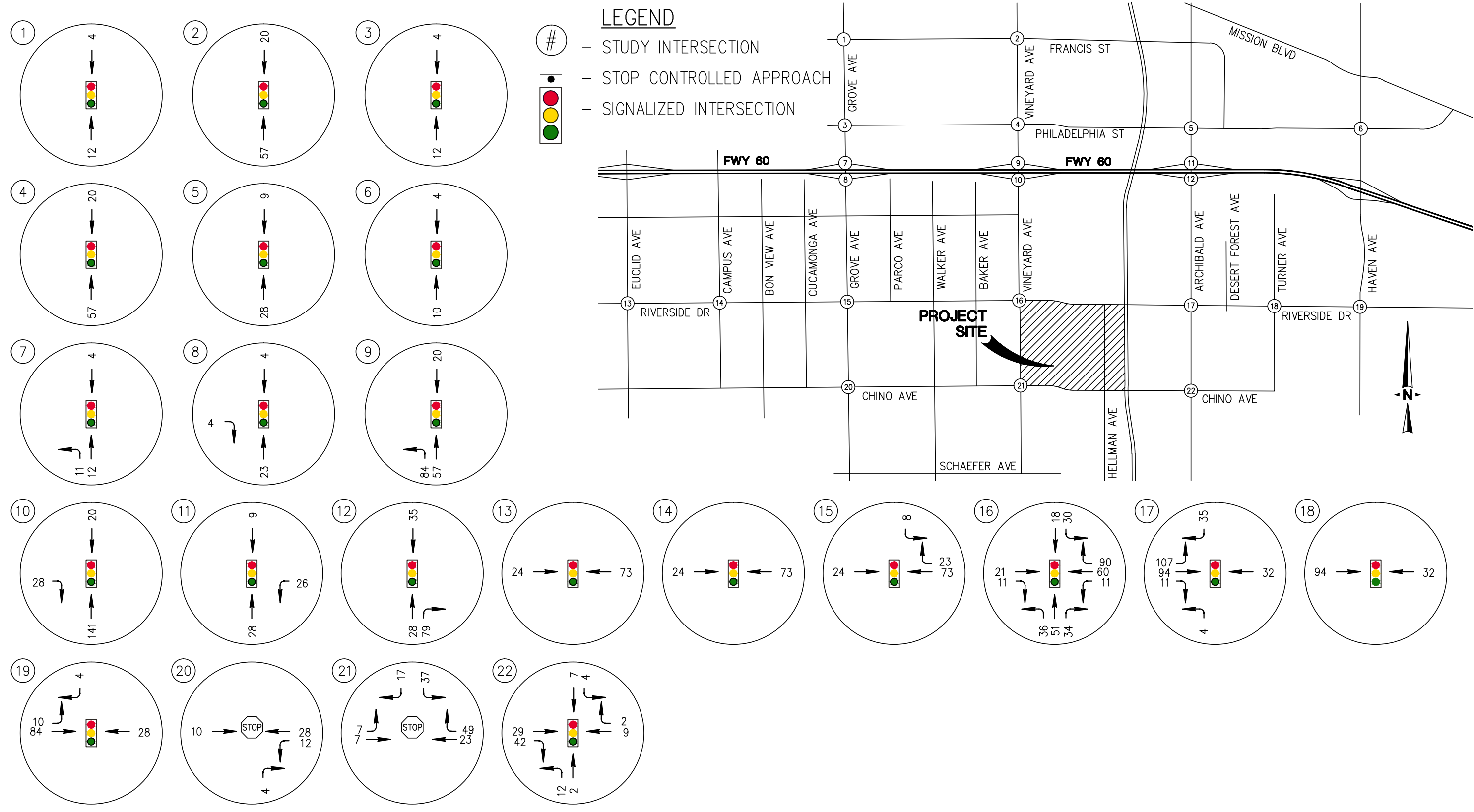

PREPARED BY:



**ARMSTRONG RANCH
TRAFFIC IMPACT STUDY
ONTARIO, CA**

**FIGURE 22A
PHASE 3 (2021) PROJECT AM PEAK HOUR
STUDY AREA TRAFFIC VOLUMES**

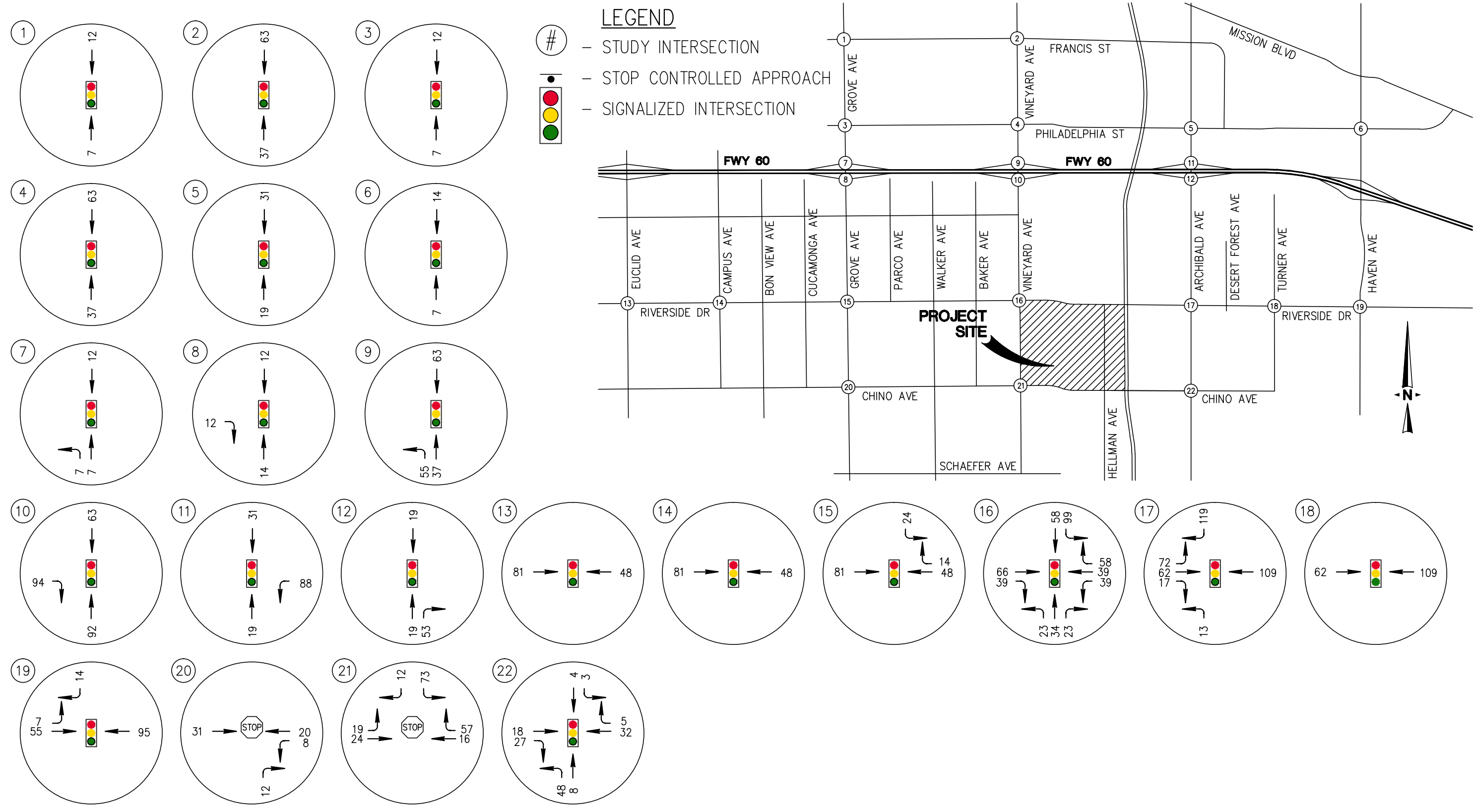

PREPARED BY:



**ARMSTRONG RANCH
TRAFFIC IMPACT STUDY
ONTARIO, CA**

**FIGURE 22B
PHASE 3 (2021) PROJECT PM PEAK HOUR
STUDY AREA TRAFFIC VOLUMES**

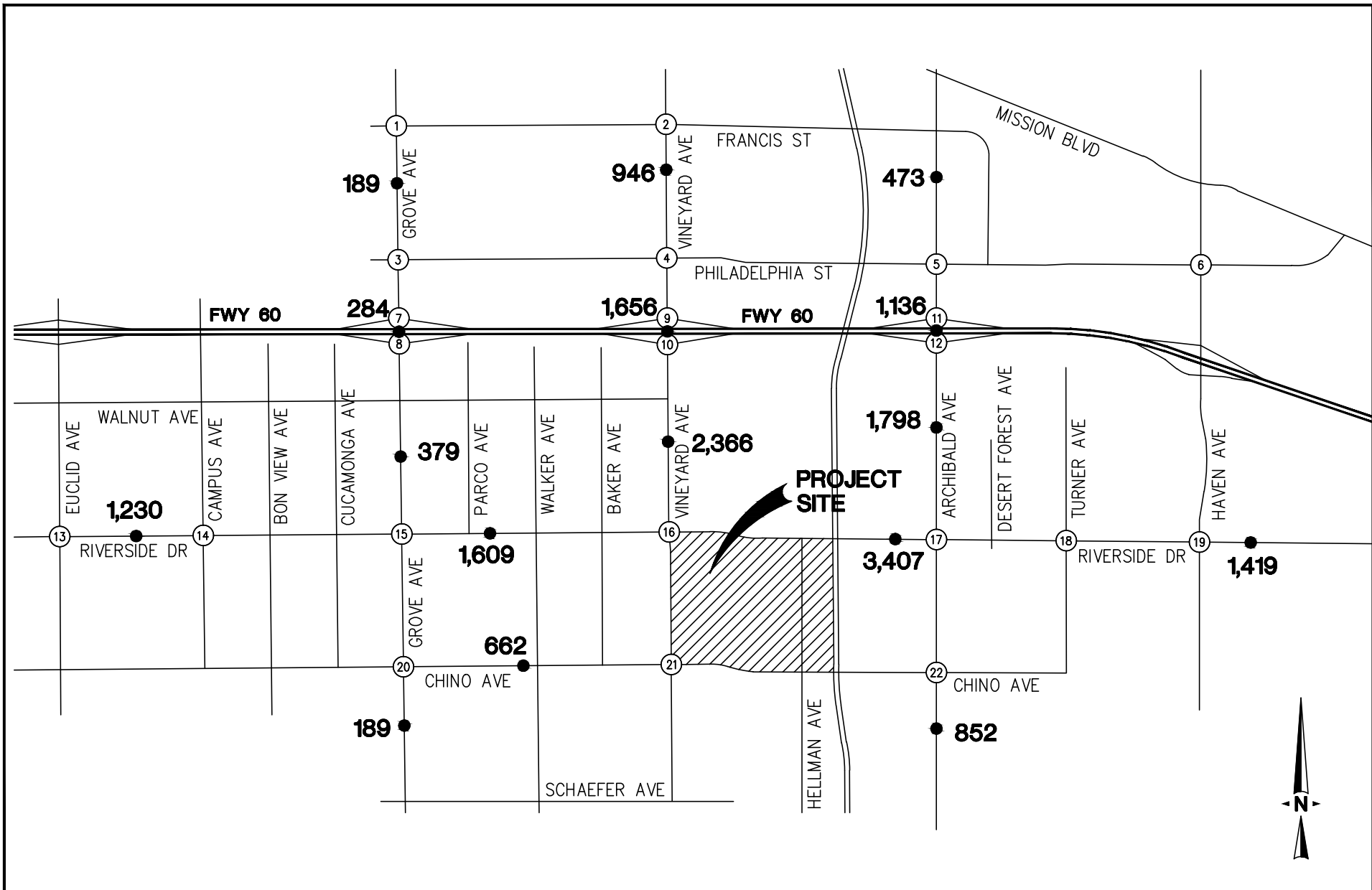

PREPARED BY:



**ARMSTRONG RANCH
TRAFFIC IMPACT STUDY
ONTARIO, CA**

**FIGURE 23
PHASE 3 (2021) PROJECT WEEKDAY
DAILY STUDY AREA TRAFFIC VOLUMES**

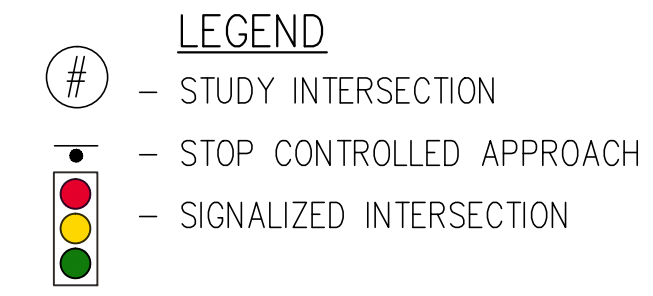
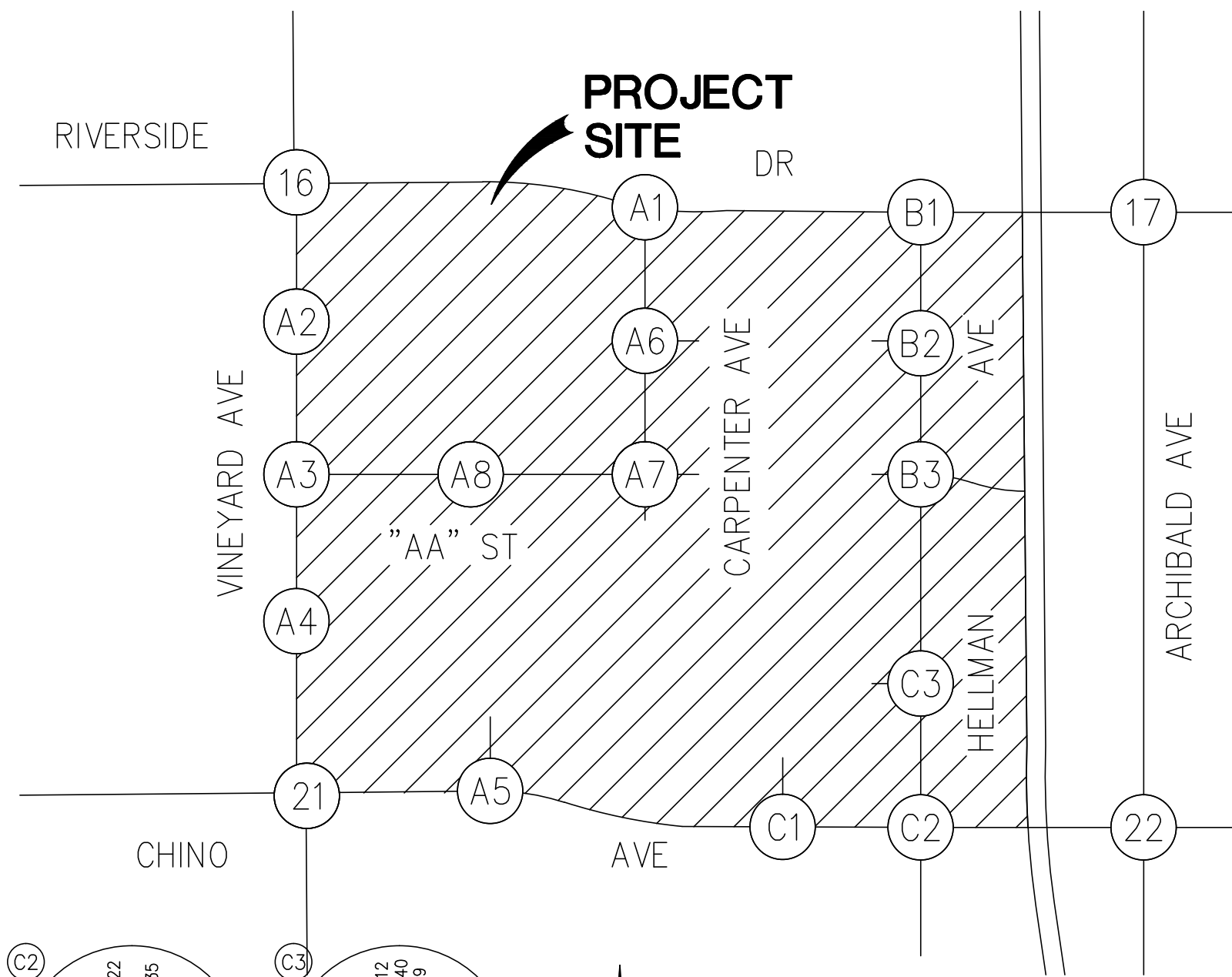
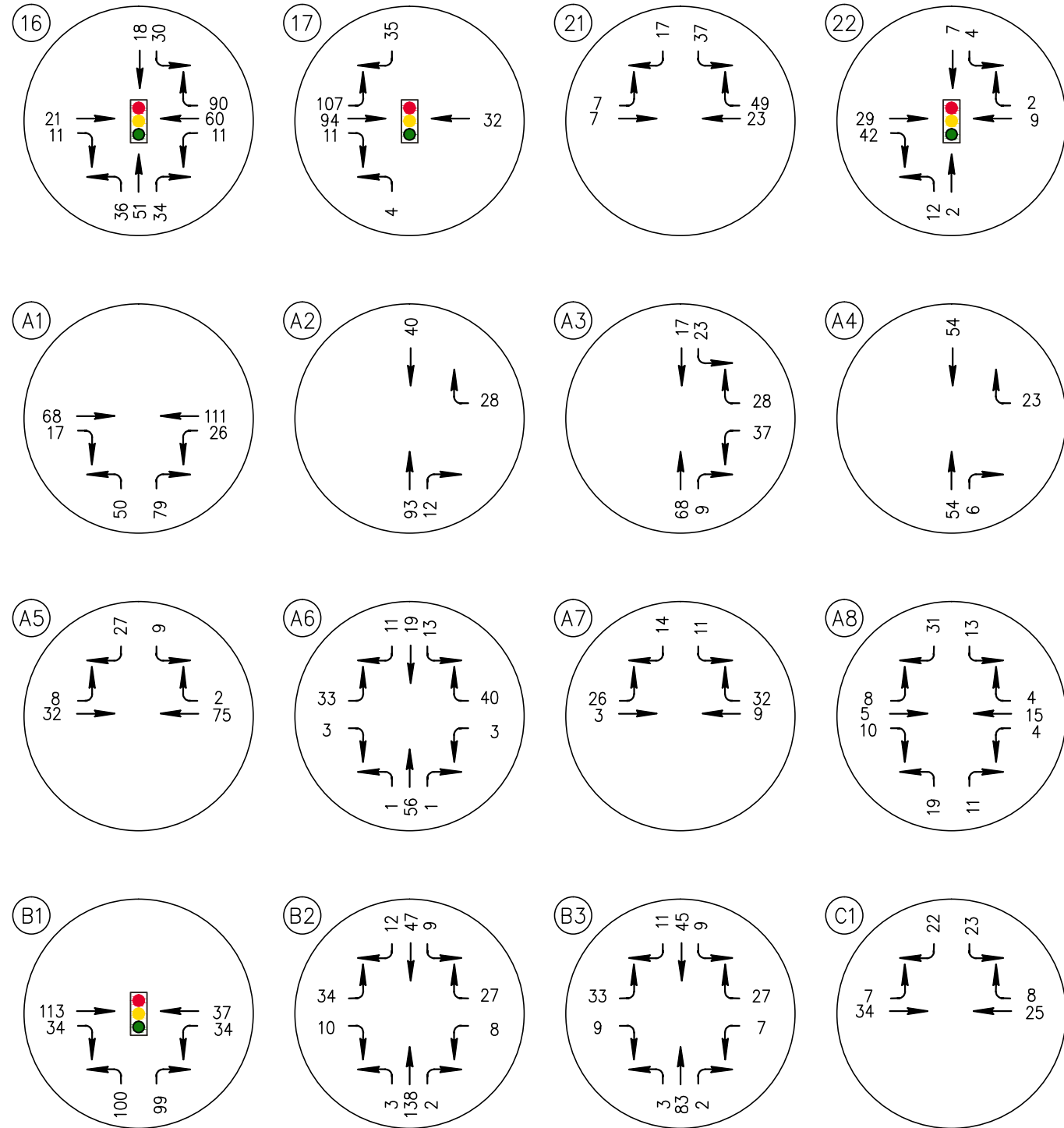

PREPARED BY:



**ARMSTRONG RANCH
TRAFFIC IMPACT STUDY
ONTARIO, CA**

**FIGURE 24A
PHASE 3 (2021) PROJECT AM PEAK HOUR
ACCESS AND ON-SITE INTERSECTION VOLUMES**

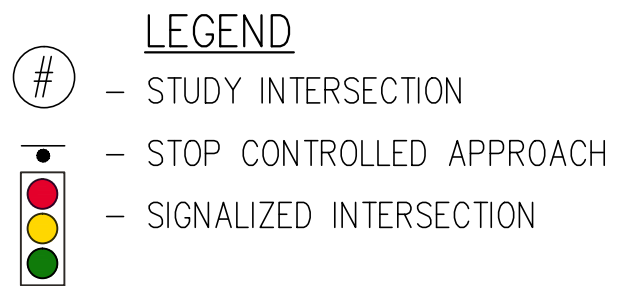
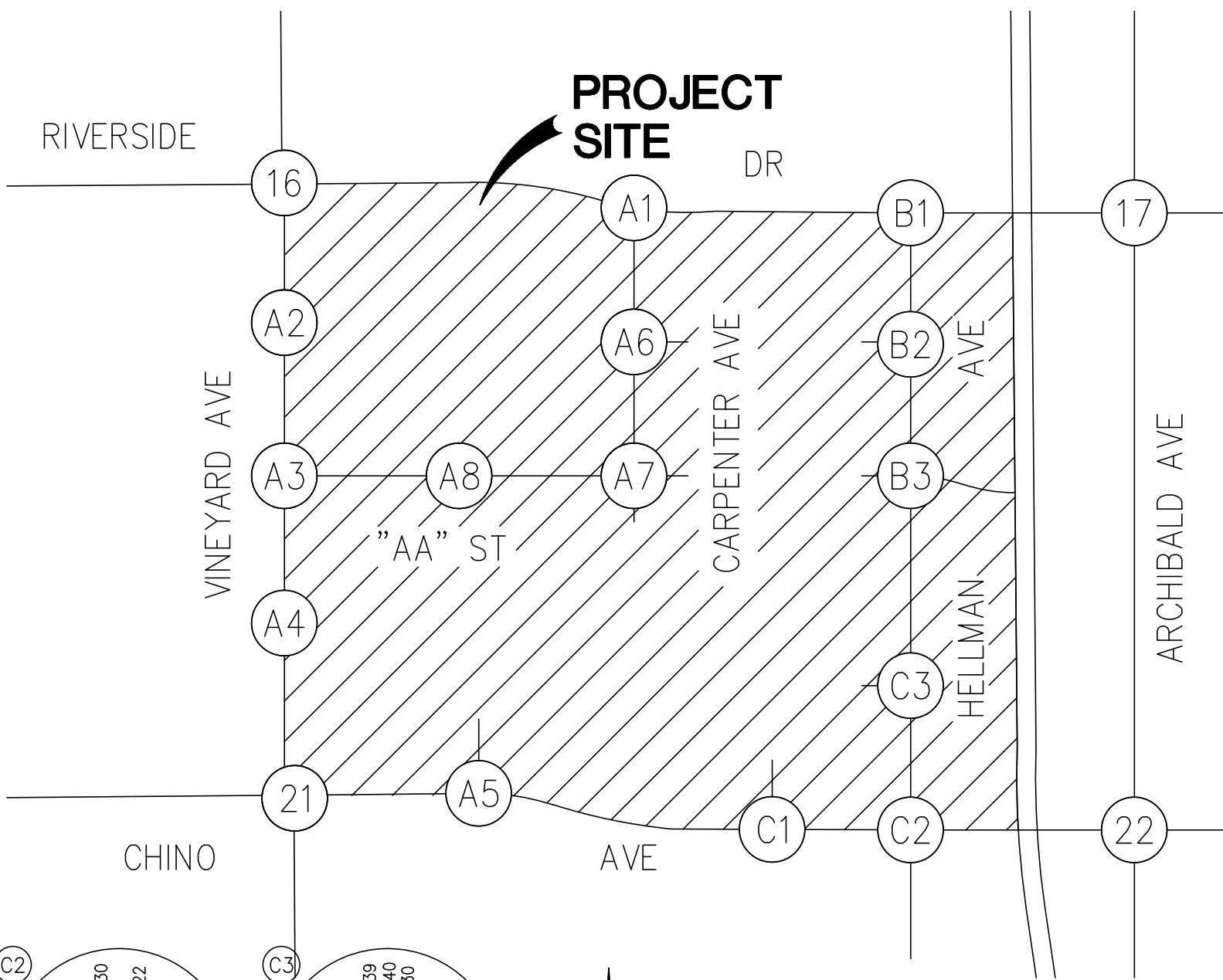
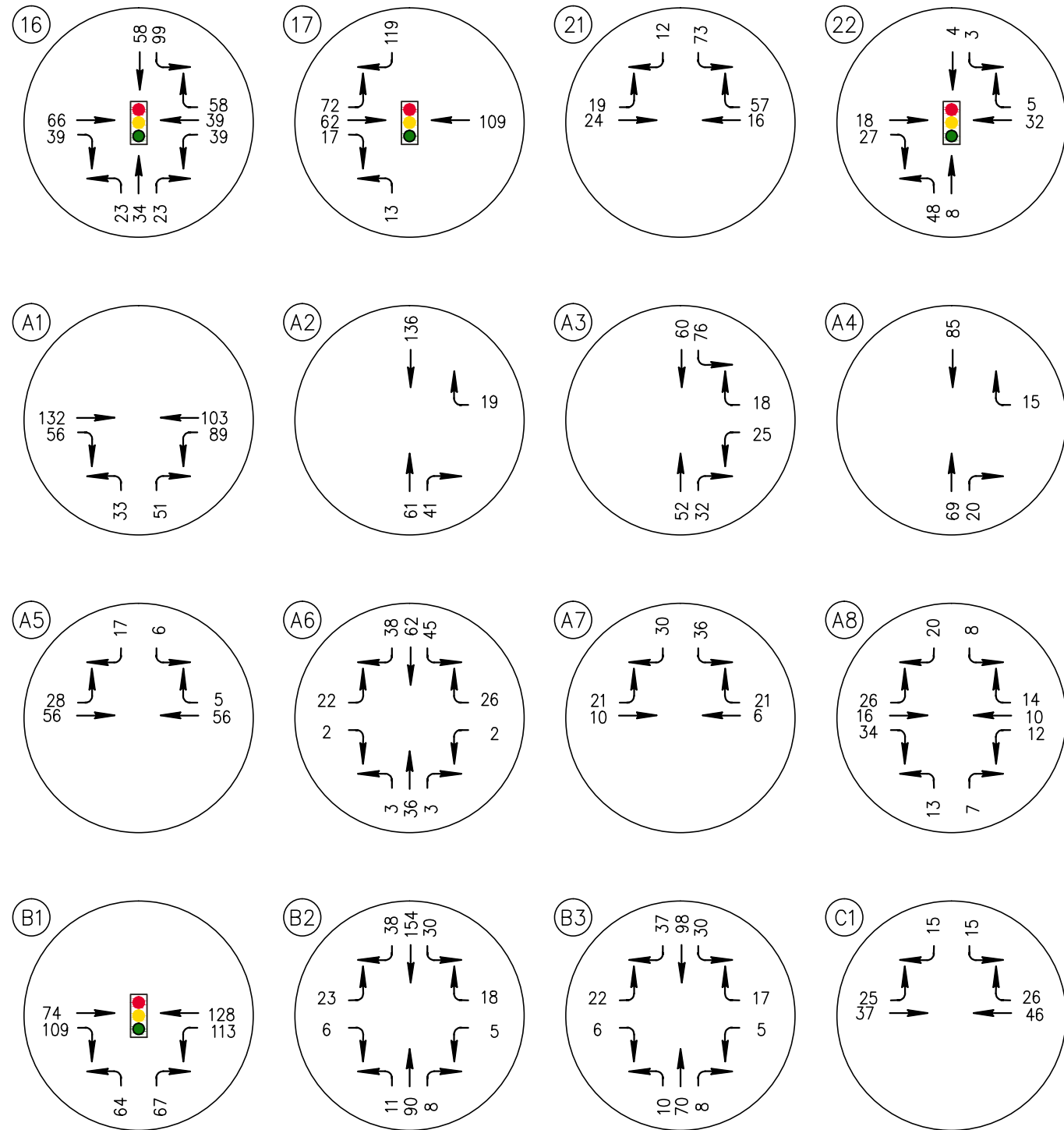

PREPARED BY:



**ARMSTRONG RANCH
TRAFFIC IMPACT STUDY
ONTARIO, CA**

**FIGURE 24B
PHASE 3 (2021) PROJECT PM PEAK HOUR
ACCESS AND ON-SITE INTERSECTION VOLUMES**

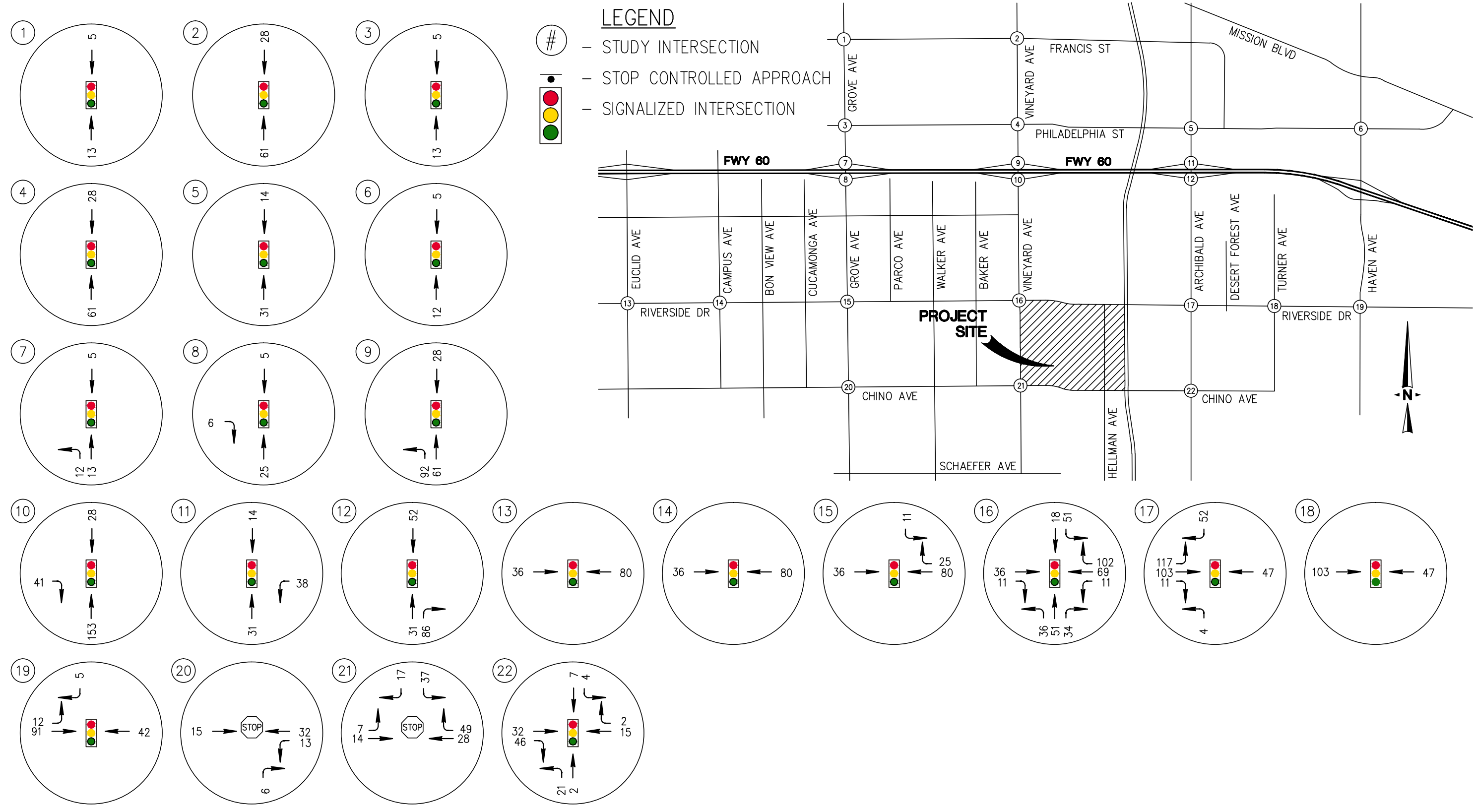

PREPARED BY:



**ARMSTRONG RANCH
TRAFFIC IMPACT STUDY
ONTARIO, CA**

**FIGURE 25A
PHASE 3 (2021) WITH SCHOOL PROJECT
AM PEAK HOUR STUDY AREA TRAFFIC VOLUME**

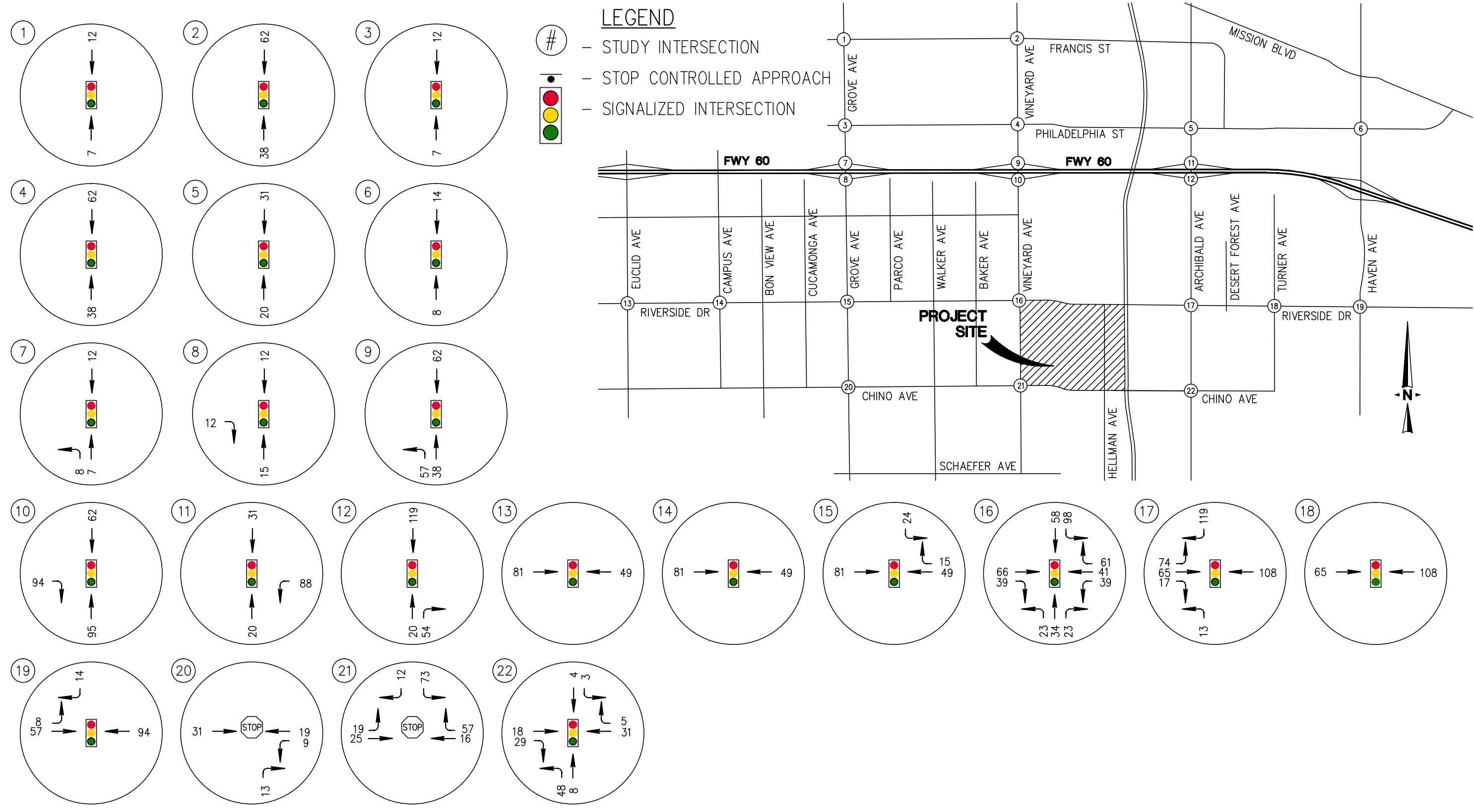

PREPARED BY:



**ARMSTRONG RANCH
TRAFFIC IMPACT STUDY
ONTARIO, CA**

**FIGURE 25B
PHASE 3 (2021) WITH SCHOOL PROJECT
PM PEAK HOUR STUDY AREA TRAFFIC VOLUME**

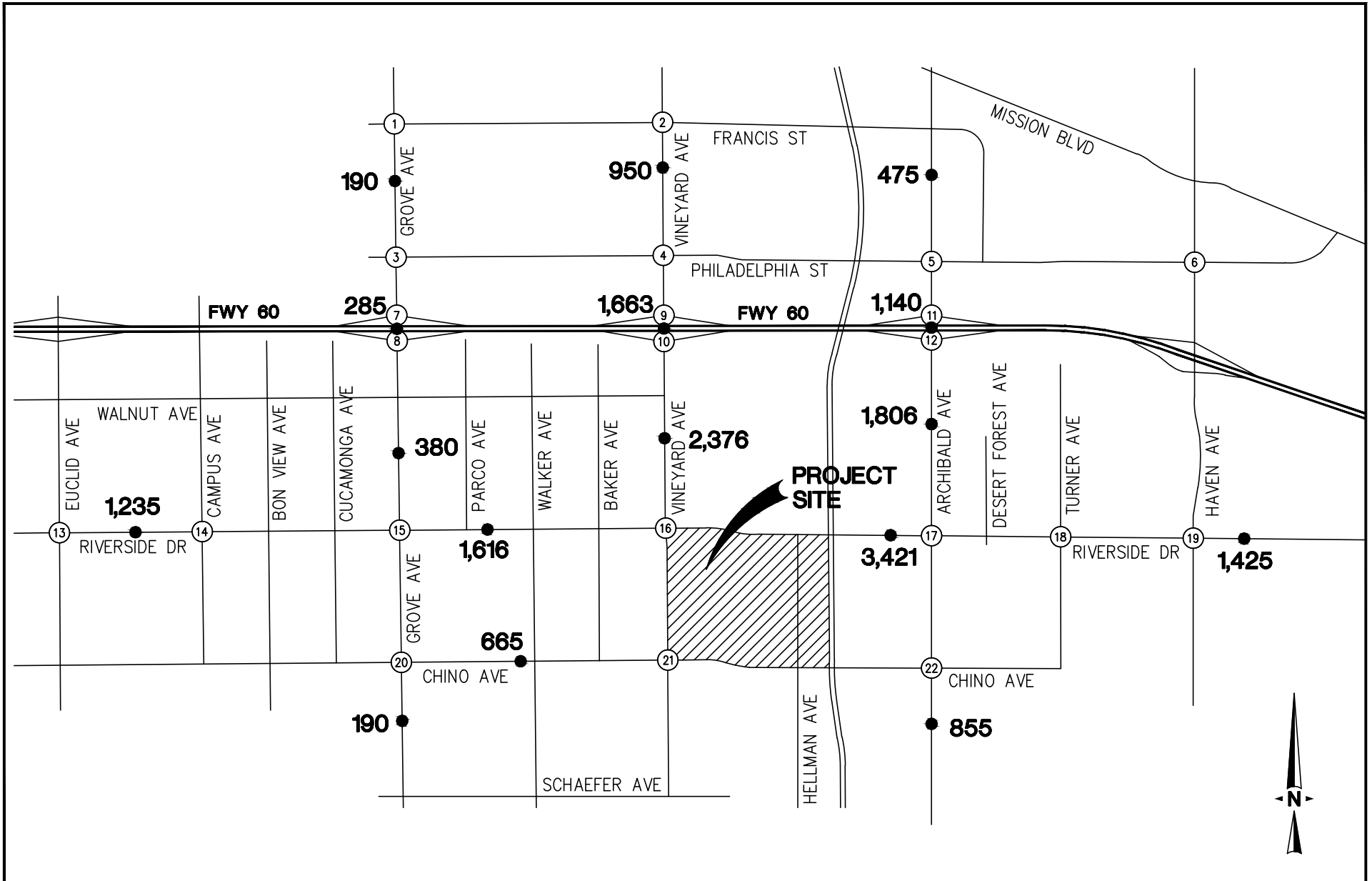

PREPARED BY:



**ARMSTRONG RANCH
TRAFFIC IMPACT STUDY
ONTARIO, CA**

**FIGURE 26
PHASE 3 (2021) WITH SCHOOL PROJECT
WEEKDAY DAILY STUDY AREA TRAFFIC VOLUMES**

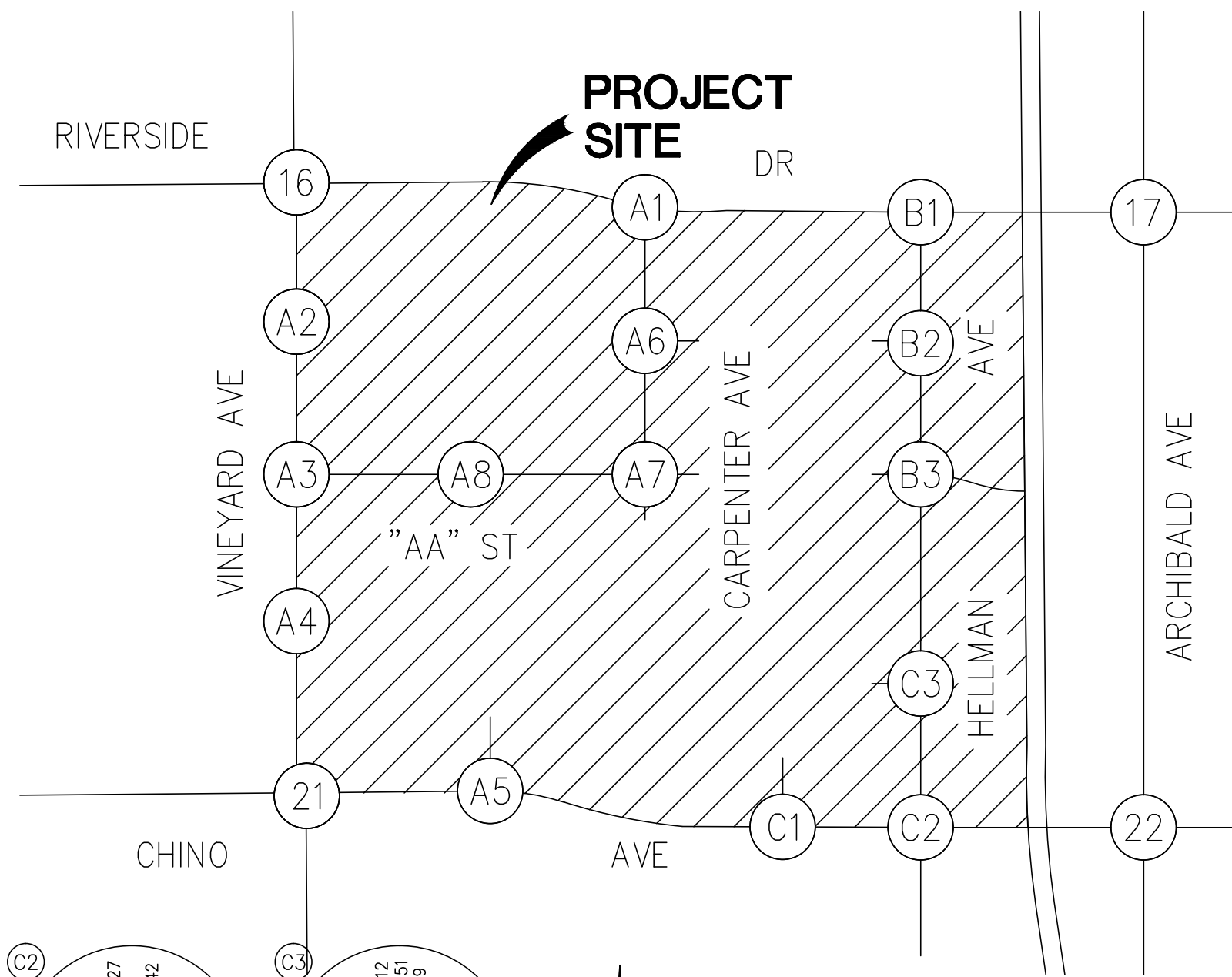
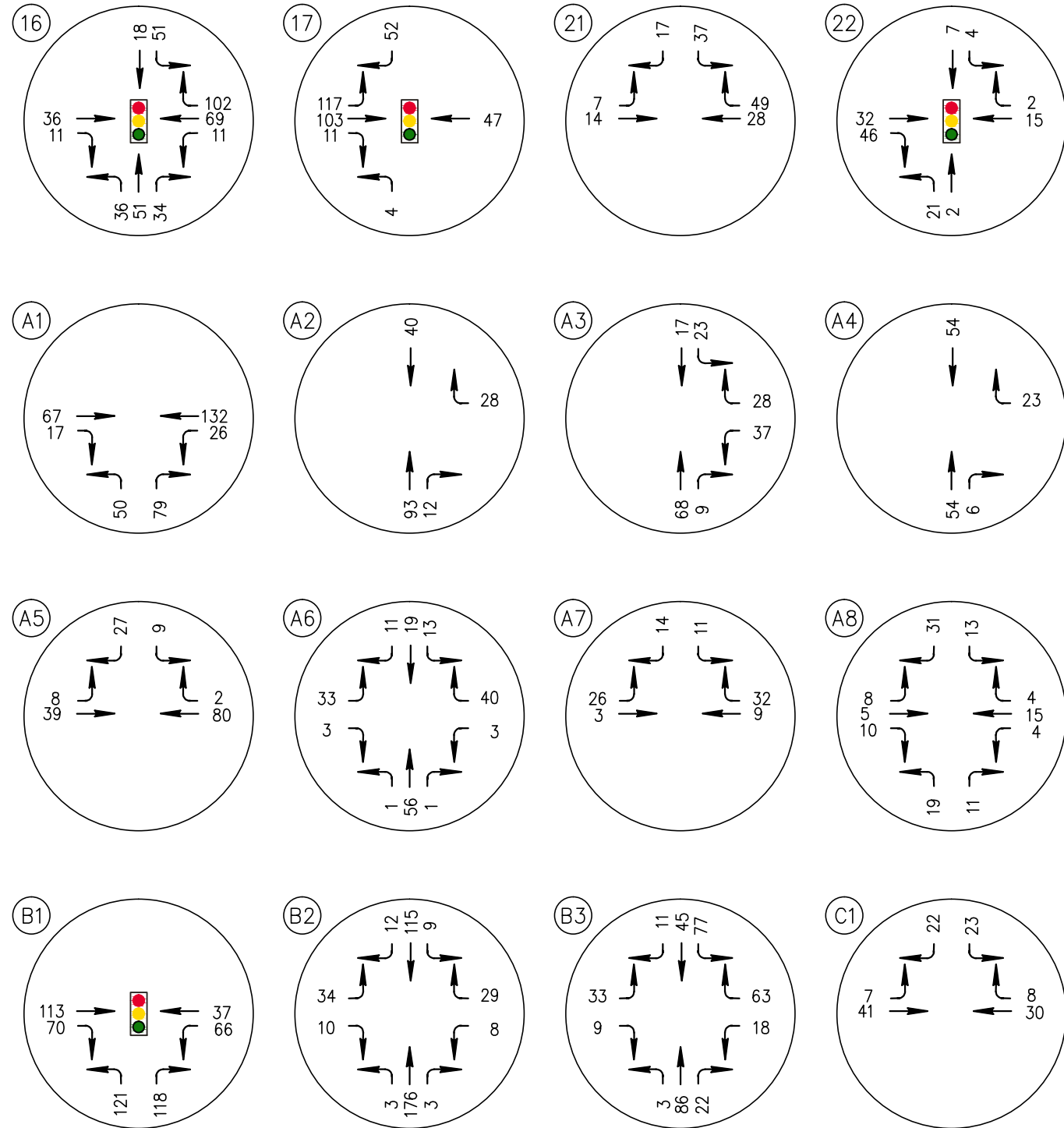

LEGEND

- # - STUDY INTERSECTION
- - STOP CONTROLLED APPROACH
- 🚦 - SIGNALIZED INTERSECTION

PREPARED BY:



**ARMSTRONG RANCH
TRAFFIC IMPACT STUDY
ONTARIO, CA**

**FIGURE 27A
PHASE 3 (2021) WITH SCHOOL PROJECT AM PEAK HOUR
ACCESS AND ON-SITE INTERSECTION VOLUMES**

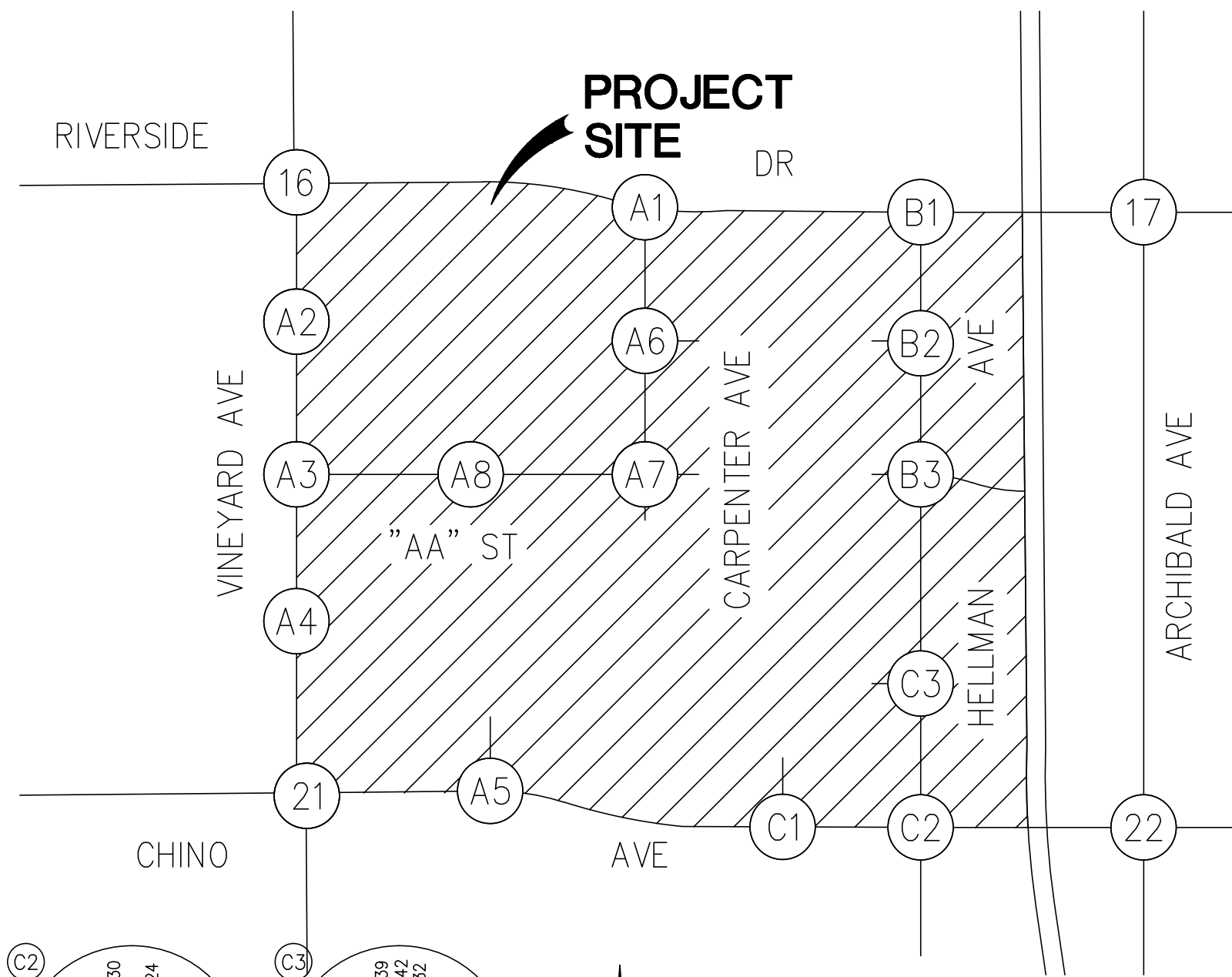
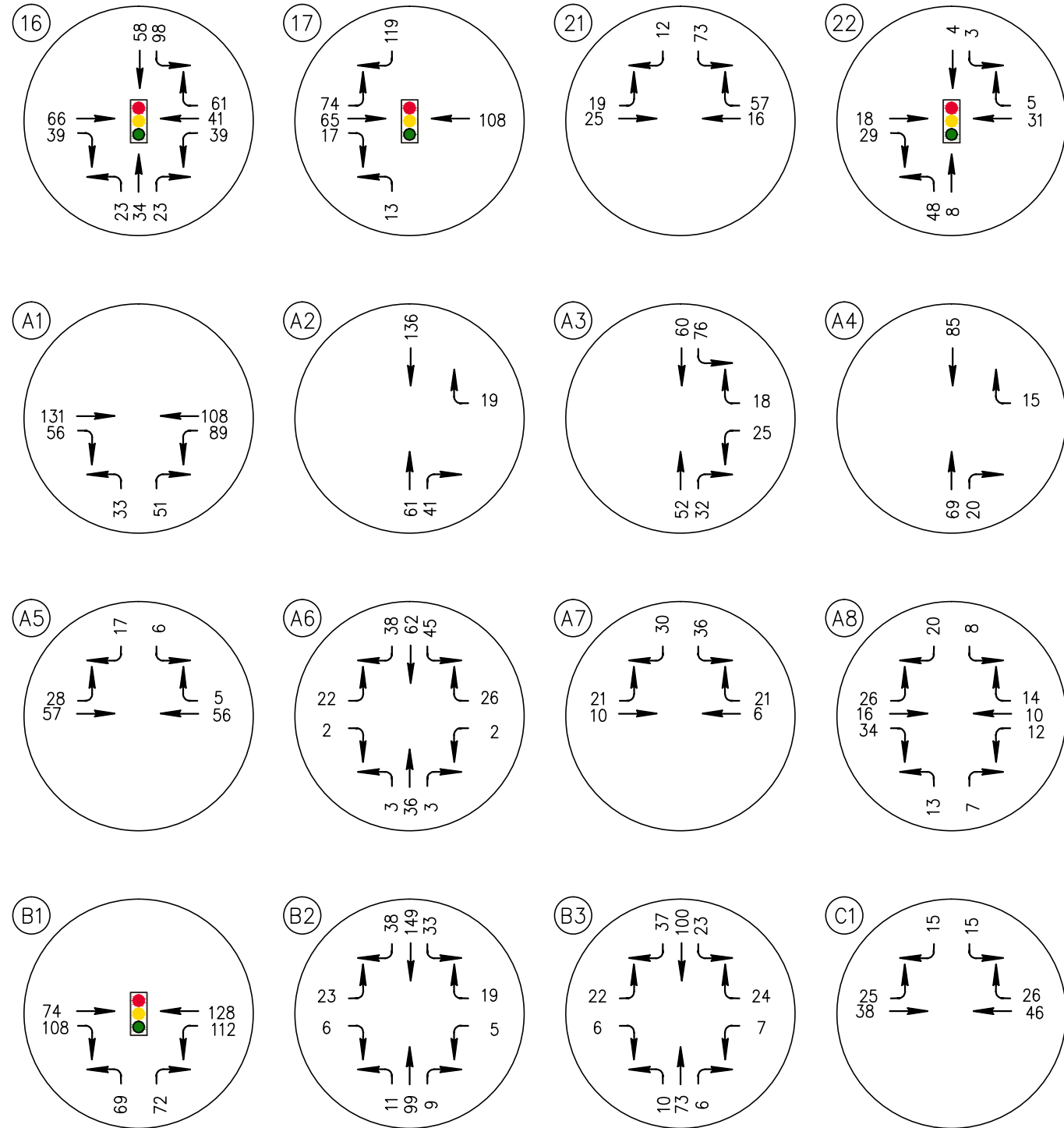

PROJECT SITE



- LEGEND**
- # - STUDY INTERSECTION
 - - STOP CONTROLLED APPROACH
 - 🚦 - SIGNALIZED INTERSECTION

PREPARED BY:



**ARMSTRONG RANCH
TRAFFIC IMPACT STUDY
ONTARIO, CA**

**FIGURE 27B
PHASE 3 (2021) WITH SCHOOL PROJECT PM PEAK HOUR
ACCESS AND ON-SITE INTERSECTION VOLUMES**

C. BASELINE WITH PROJECT TRAFFIC VOLUME FORECASTS

For each phase year, project traffic volumes were combined with existing, ambient growth, and cumulative project volumes to develop total baseline with project traffic volume forecasts.

C.1 Phase 1 (2017) Baseline with Project Traffic Volumes

Figures 28A and 28B show Phase 1 Baseline with Project am and pm peak hour volumes at off-site study area intersections, respectively. These exhibits show the total peak hour turning movement volumes at off-site study area intersections and the total (two-way) peak hour volumes on roadway links between intersections. Figure 29 shows Phase 1 Baseline with Project weekday daily traffic volumes within the study area. Figures 30A and 30B show Phase 1 Baseline with Project am and pm peak hour on-site access intersection volumes, respectively.

C.2 Phase 2 (2019) Baseline with Project Traffic Volumes

Figures 31A and 31B show Phase 2 Baseline with Project am and pm peak hour volumes at off-site study area intersections, respectively. These exhibits show the total peak hour turning movement volumes at off-site study area intersections and the total (two-way) peak hour volumes on roadway links between intersections. Figure 32 shows Phase 2 Baseline with Project weekday daily traffic volumes within the study area. Figures 33A and 33B show Phase 2 Baseline with Project am and pm peak hour on-site access intersection volumes, respectively.

C.3 Phase 3 (2021) Baseline with Project Traffic Volumes (without elementary school)

Figures 34A and 34B show Phase 3 Baseline with Project (without school) am and pm peak hour volumes at off-site study area intersections, respectively. These exhibits show the total peak hour turning movement volumes at off-site study area intersections and the total (two-way) peak hour volumes on roadway links between intersections. Figure 35 shows Phase 3 Baseline with Project (without school) weekday daily traffic volumes

July 2016

within the study area. Figures 36A and 36B show Phase 3 Baseline with Project (without school) am and pm peak hour on-site access intersection volumes, respectively.

C.4 Phase 3 (2021) Baseline with Project Traffic Volumes (with elementary school)

Figures 37A and 37B show Phase 3 Baseline with Project (with school) am and pm peak hour volumes at off-site study area intersections, respectively. These exhibits show the total peak hour turning movement volumes at off-site study area intersections and the total (two-way) peak hour volumes on roadway links between intersections. Figure 38 shows Phase 3 Baseline with Project (with school) weekday daily traffic volumes within the study area. Figures 39A and 39B show Phase 3 Baseline with Project (with school) am and pm peak hour on-site access intersection volumes, respectively.

C.5 SR-60 Freeway Mainline Analysis with Phase 3 (2021) Baseline with Project Peak Hour Volumes (with elementary school)

Figure 40 provides a summary of mainline LOS analysis for the SR-60 Freeway with worst-case Phase 3 (2021) Baseline with Project (with elementary school) peak hour volumes using the 2010 Highway Capacity Manual method for basic freeway segments. This figure shows that all SR-60 study segments will continue to operate at LOS D or C with forecast future peak hour volumes. The LOS calculations are included in the appendices.

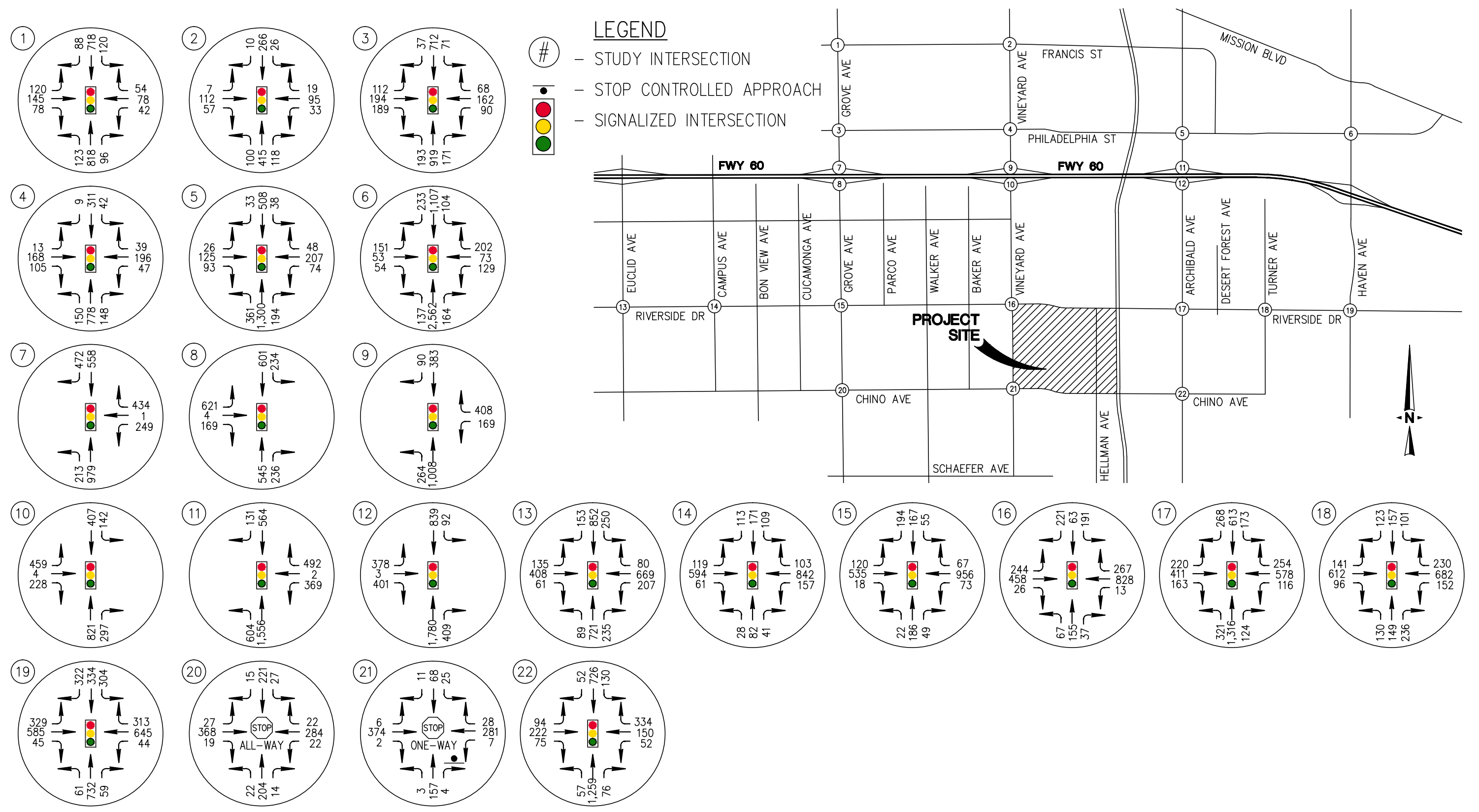

PREPARED BY:



**ARMSTRONG RANCH
TRAFFIC IMPACT STUDY
ONTARIO, CA**

**FIGURE 28A
PHASE 1 BASELINE 2017 WITH PROJECT
AM PEAK HOUR STUDY AREA TRAFFIC VOLUME**

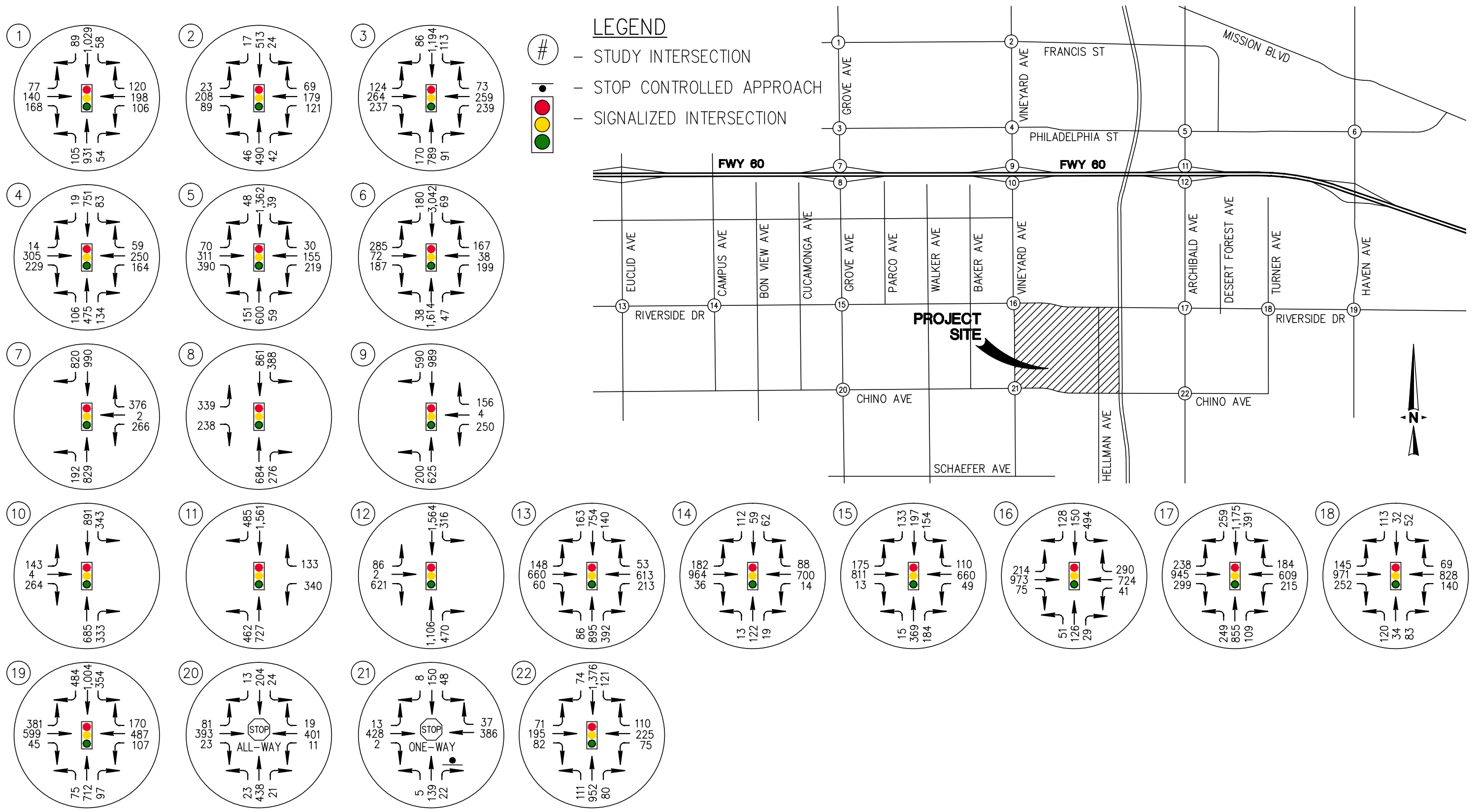

PREPARED BY:



**ARMSTRONG RANCH
TRAFFIC IMPACT STUDY
ONTARIO, CA**

**FIGURE 28B
PHASE 1 BASELINE 2017 WITH PROJECT
PM PEAK HOUR STUDY AREA TRAFFIC VOLUME**

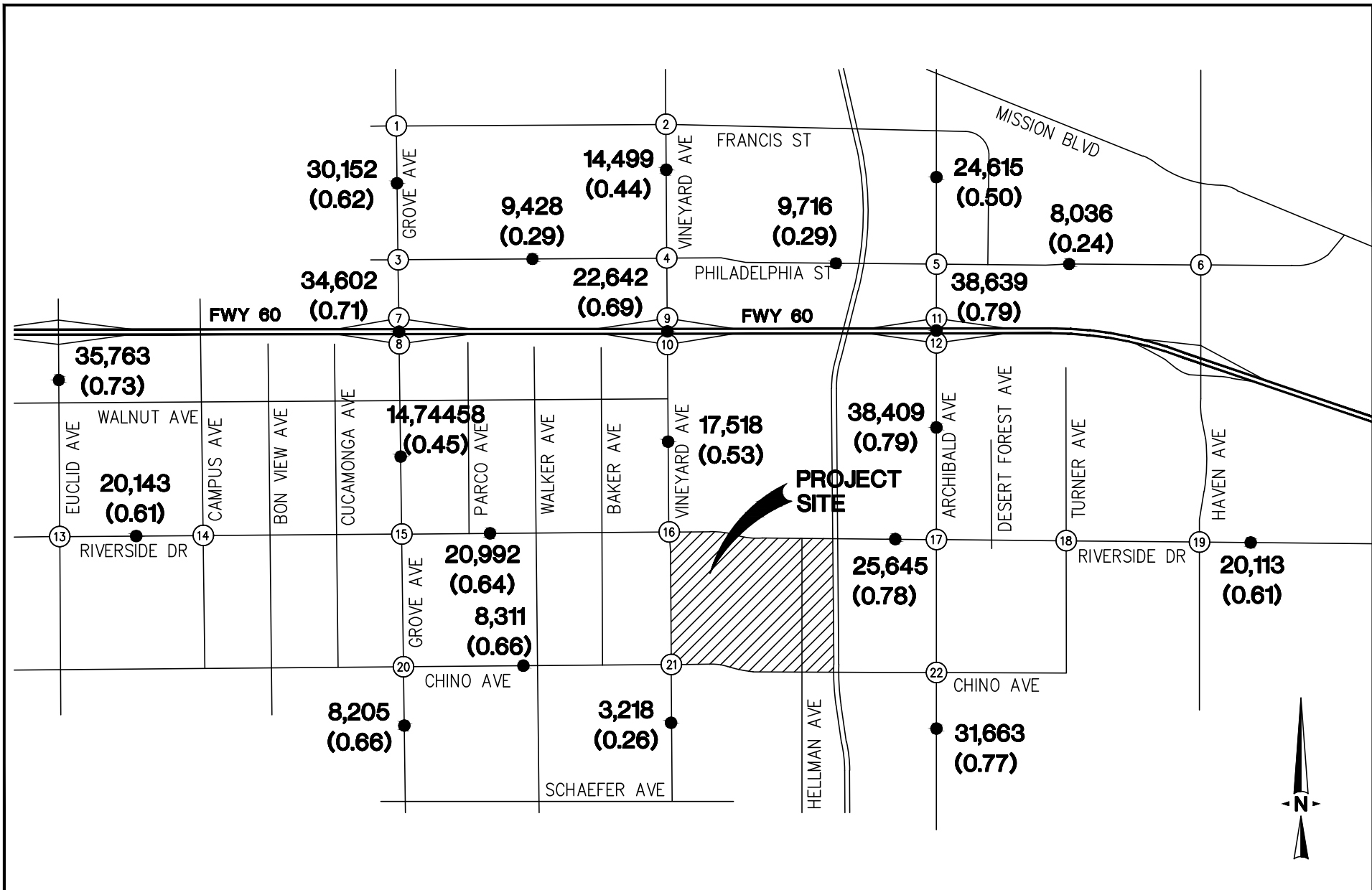

PREPARED BY:



**ARMSTRONG RANCH
TRAFFIC IMPACT STUDY
ONTARIO, CA**

**FIGURE 29
PHASE 1 BASELINE 2017 WITH PROJECT
WEEKDAY DAILY STUDY AREA TRAFFIC VOLUME**

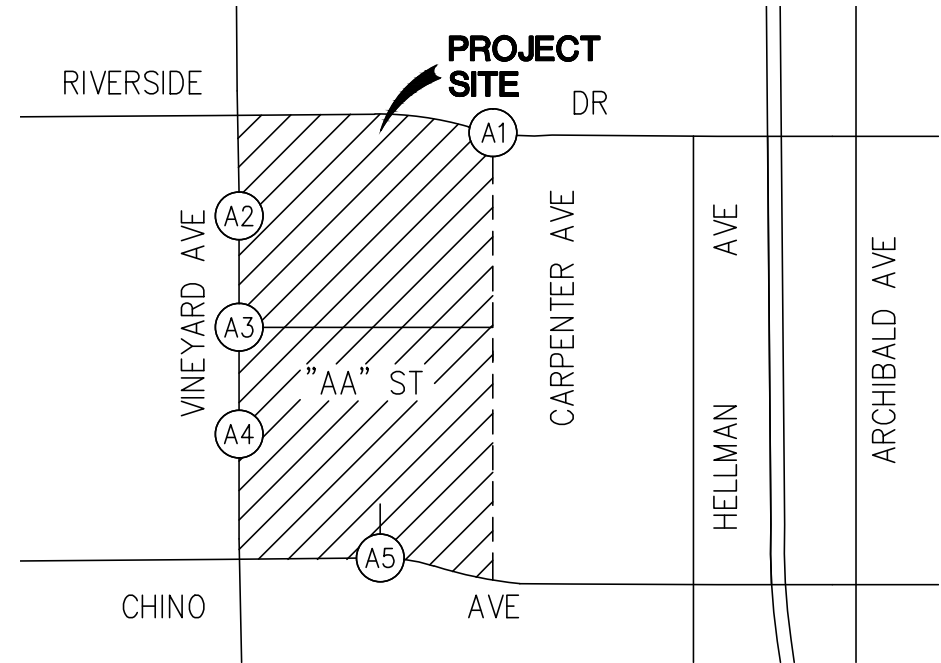
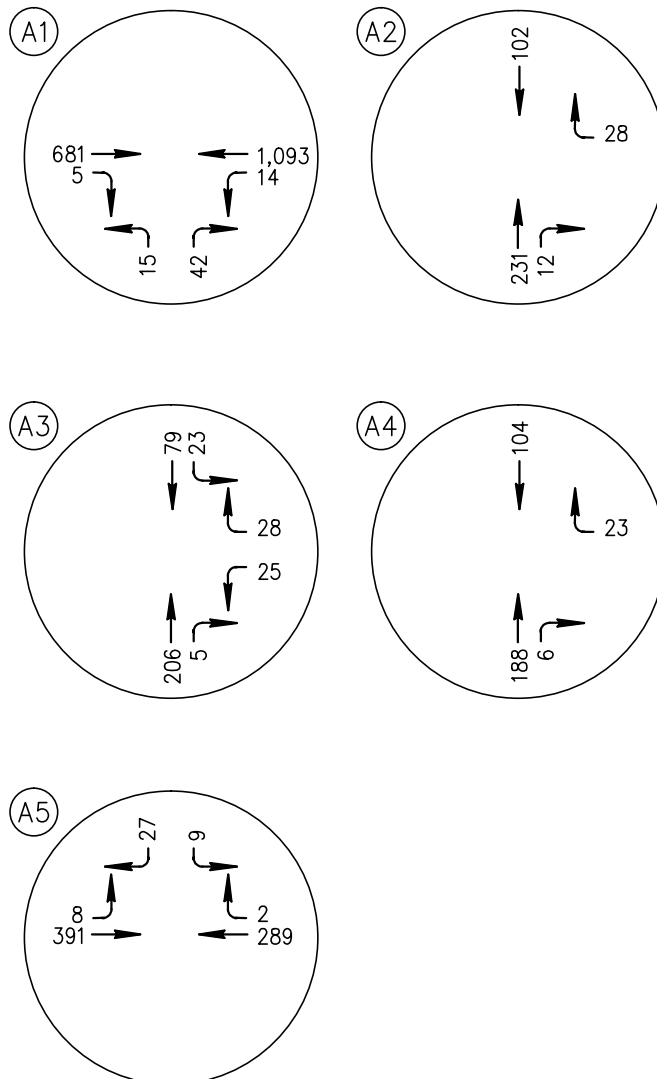

PREPARED BY:



**ARMSTRONG RANCH
TRAFFIC IMPACT STUDY
ONTARIO, CA**

**FIGURE 30A
PHASE 1 BASELINE 2017 WITH PROJECT
AM PEAK HOUR ACCESS INTERSECTION VOLUMES**

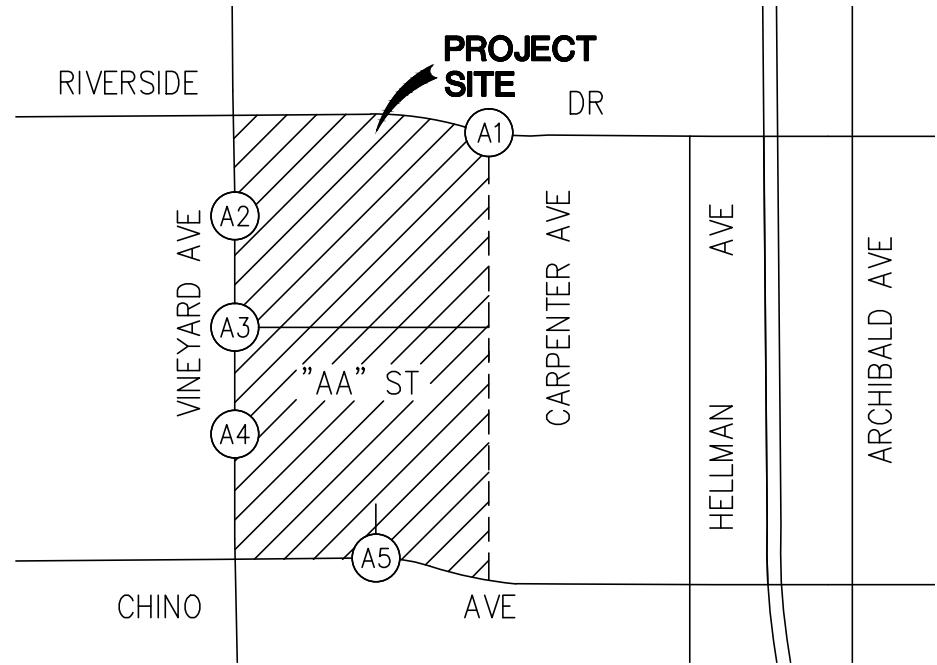
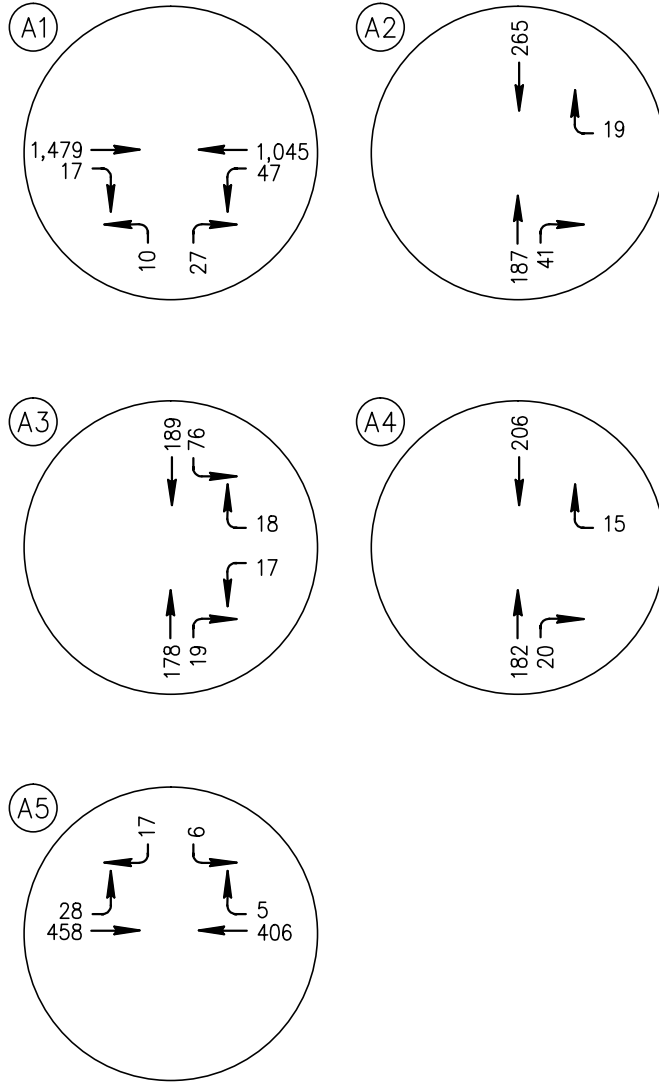

PREPARED BY:



**ARMSTRONG RANCH
TRAFFIC IMPACT STUDY
ONTARIO, CA**

**FIGURE 30B
PHASE 1 BASELINE 2017 WITH PROJECT
PM PEAK HOUR ACCESS INTERSECTION VOLUMES**

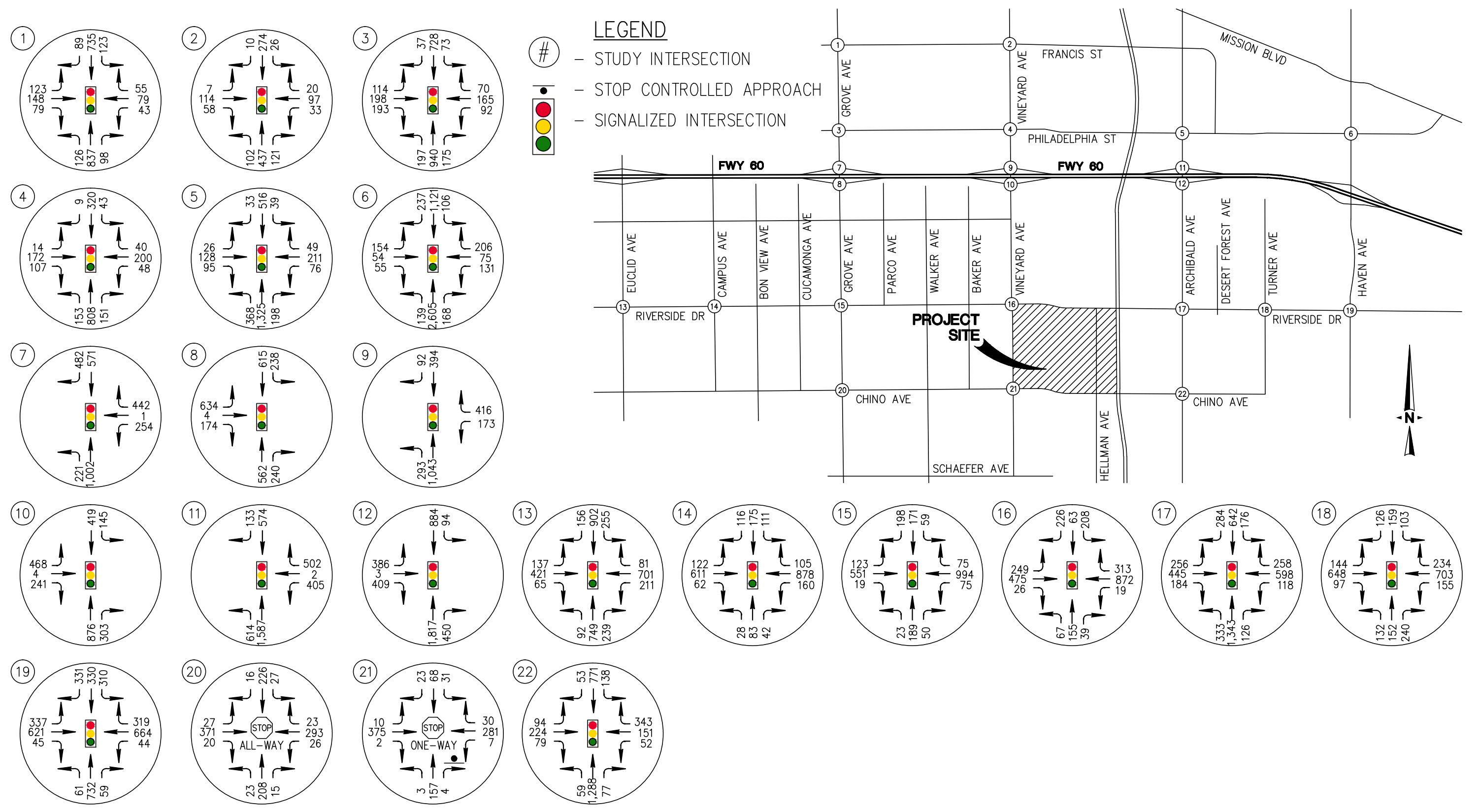

PREPARED BY:



**ARMSTRONG RANCH
TRAFFIC IMPACT STUDY
ONTARIO, CA**

**FIGURE 31A
PHASE 2 BASELINE 2019 WITH PROJECT
AM PEAK HOUR STUDY AREA TRAFFIC VOLUMES**

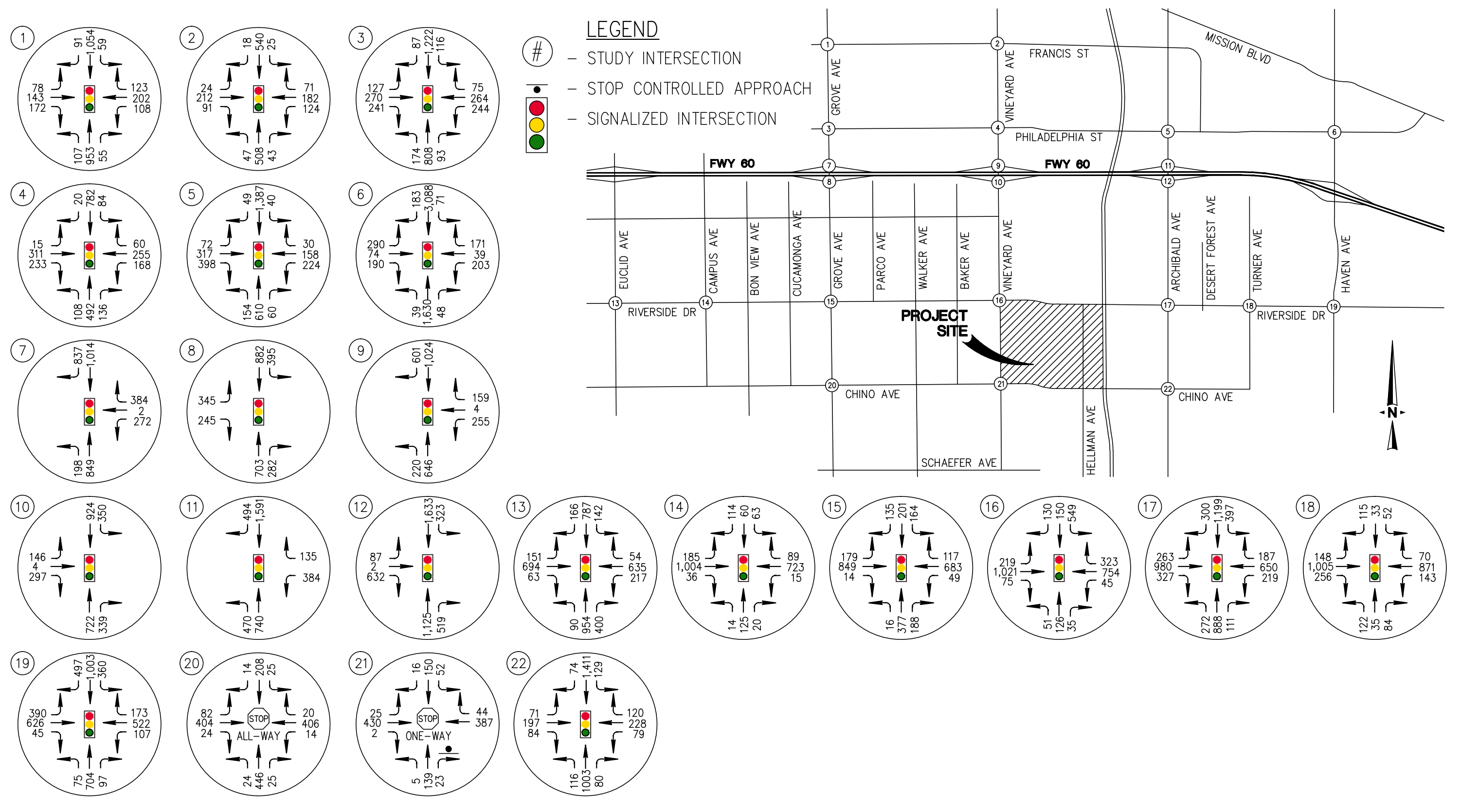

PREPARED BY:



**ARMSTRONG RANCH
TRAFFIC IMPACT STUDY
ONTARIO, CA**

**FIGURE 31B
PHASE 2 BASELINE 2019 WITH PROJECT
PM PEAK HOUR STUDY AREA TRAFFIC VOLUMES**

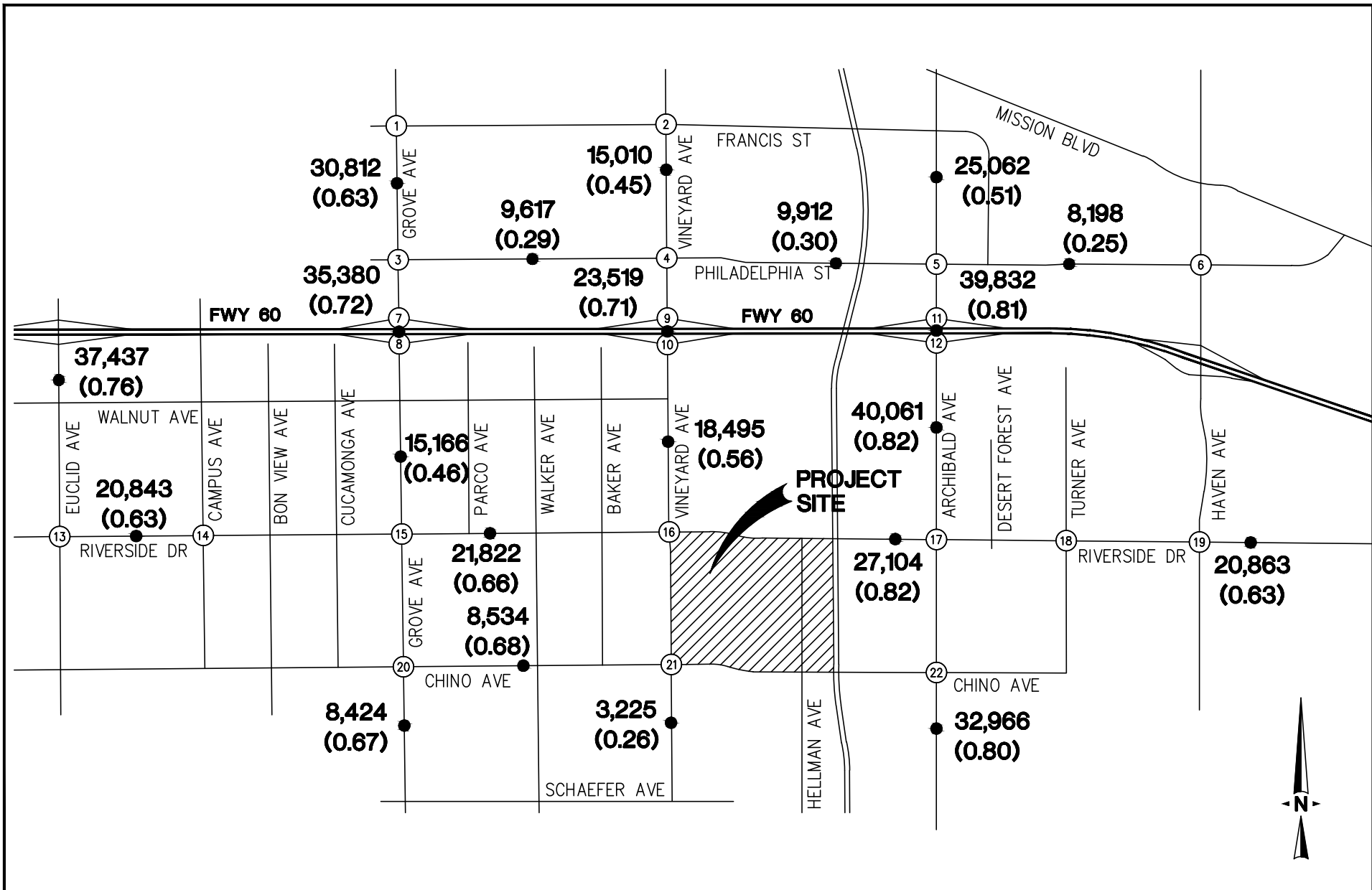

PREPARED BY:



**ARMSTRONG RANCH
TRAFFIC IMPACT STUDY
ONTARIO, CA**

**FIGURE 32
PHASE 2 BASELINE 2019 WITH PROJECT
WEEKDAY DAILY STUDY AREA TRAFFIC VOLUMES**

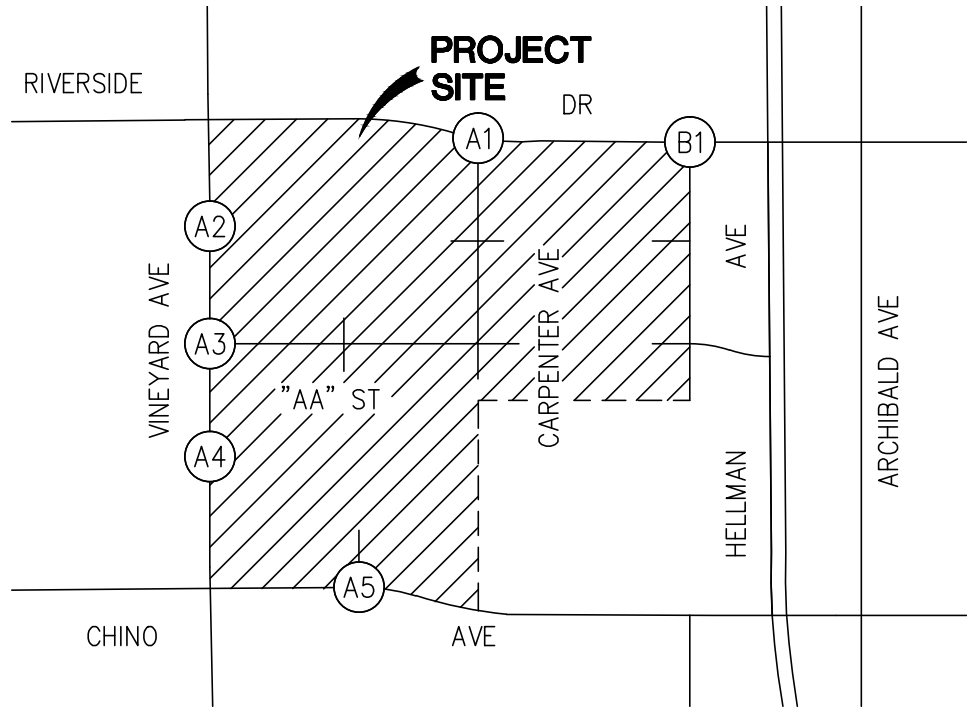
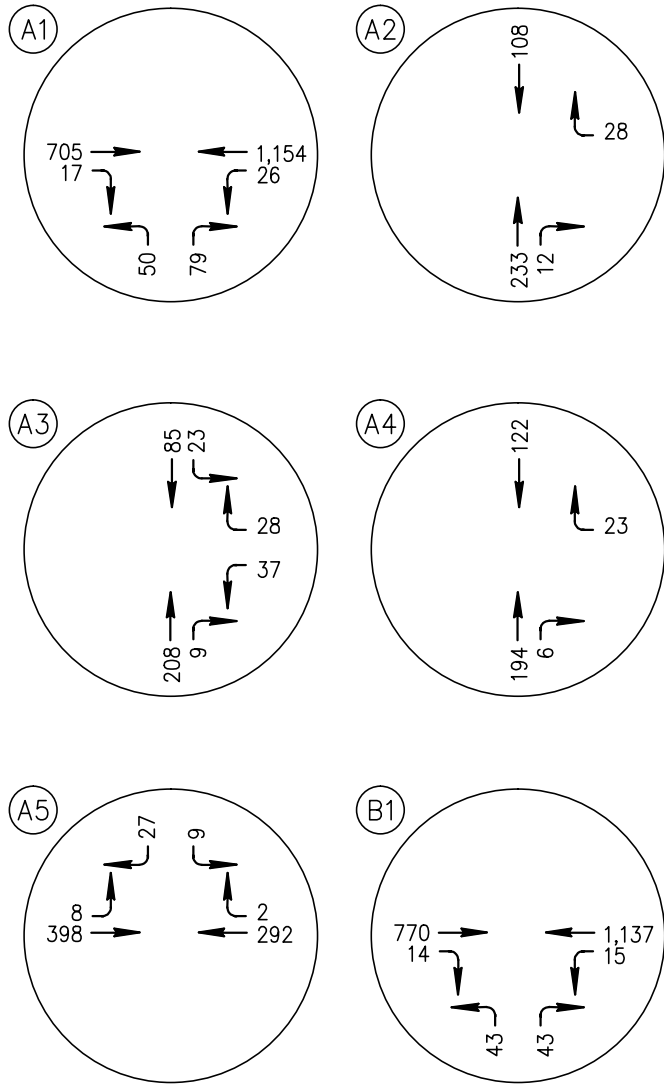

PREPARED BY:



**ARMSTRONG RANCH
 TRAFFIC IMPACT STUDY
 ONTARIO, CA**

**FIGURE 33A
 PHASE 2 BASELINE 2019 WITH PROJECT
 AM PEAK HOUR ACCESS INTERSECTION VOLUMES**

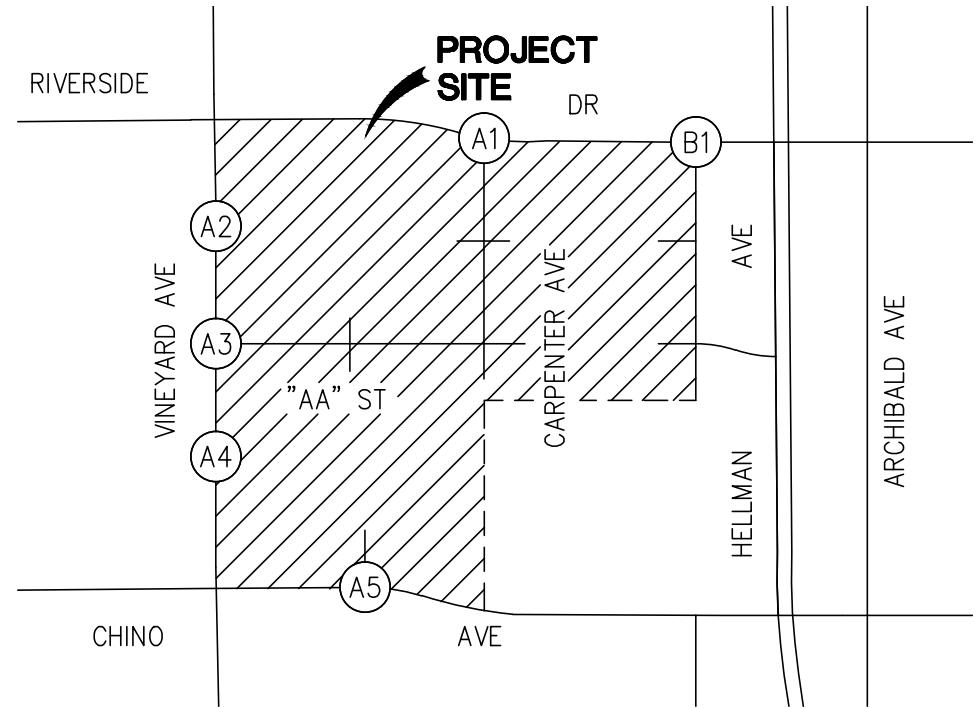
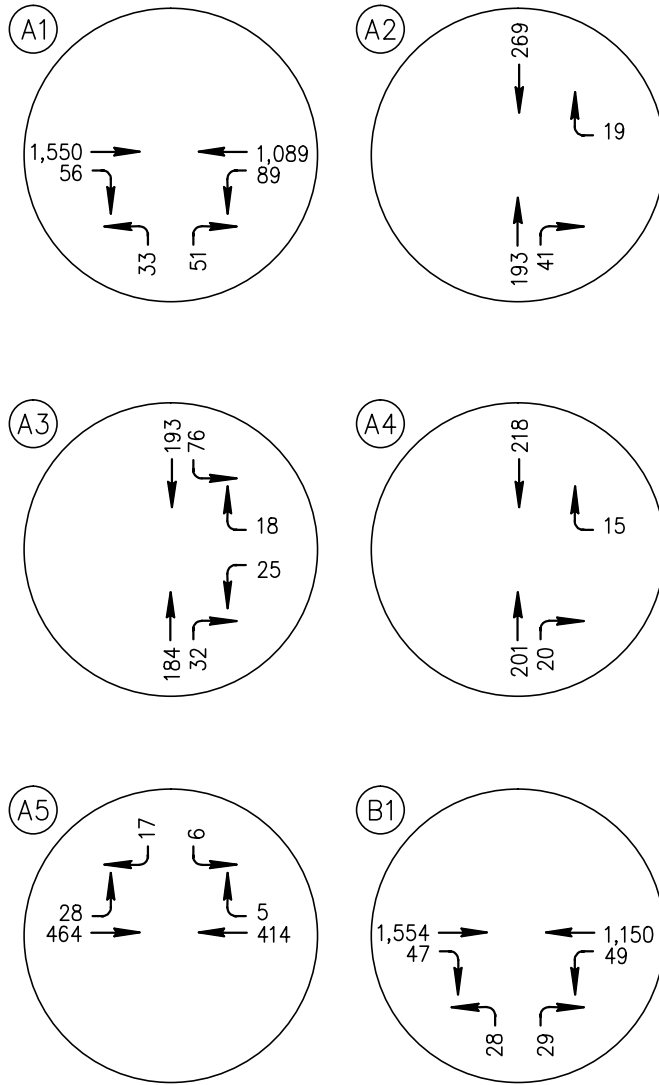

PREPARED BY:



**ARMSTRONG RANCH
TRAFFIC IMPACT STUDY
ONTARIO, CA**

**FIGURE 33B
PHASE 2 BASELINE 2019 WITH PROJECT
PM PEAK HOUR ACCESS INTERSECTION VOLUMES**

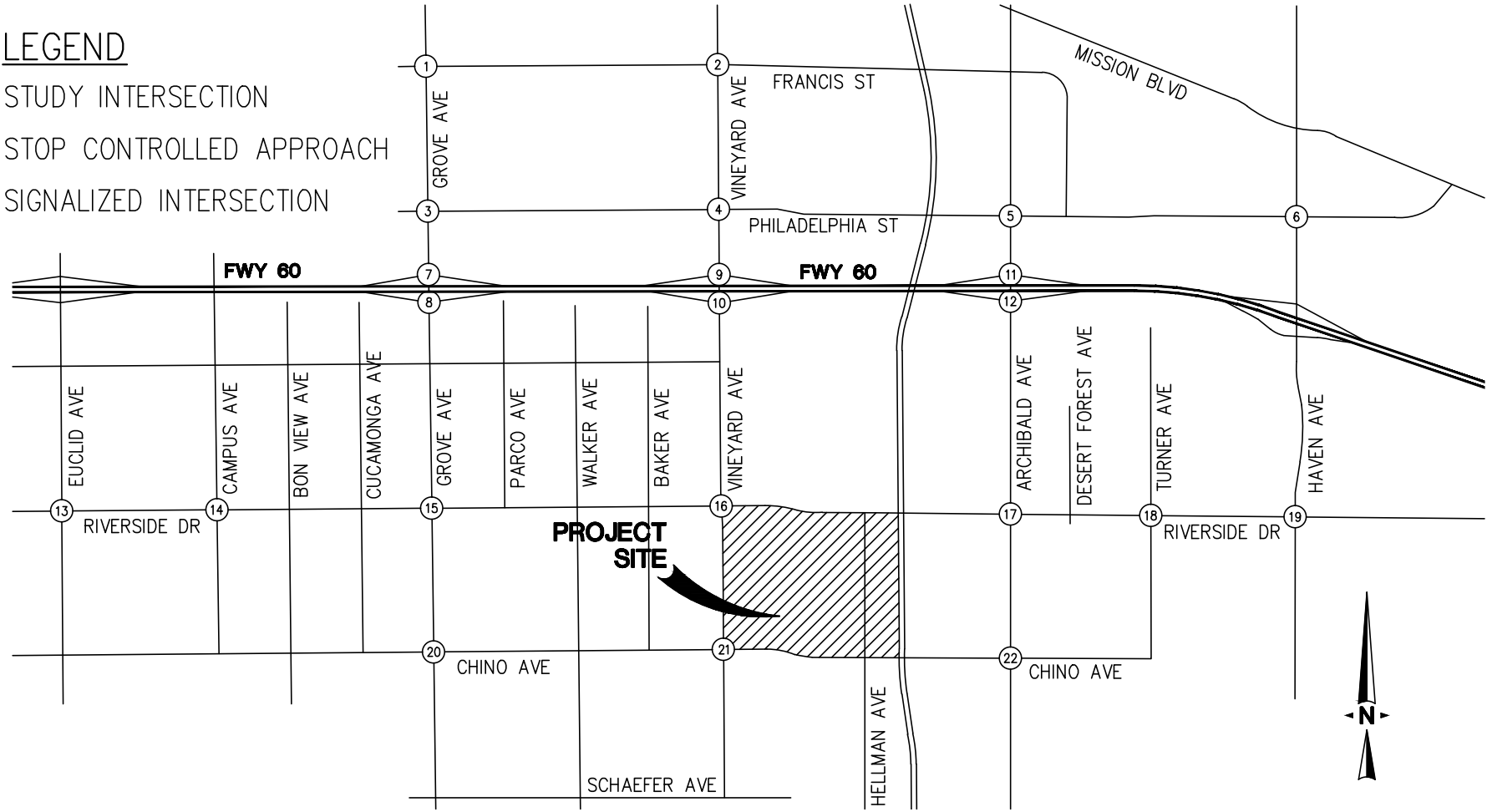
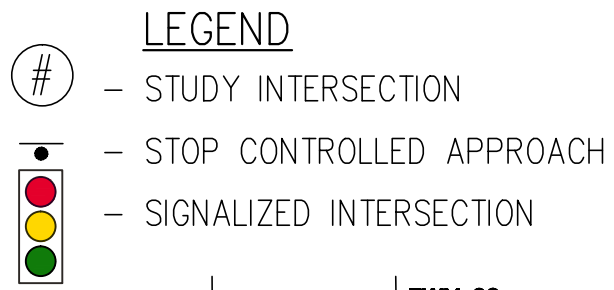
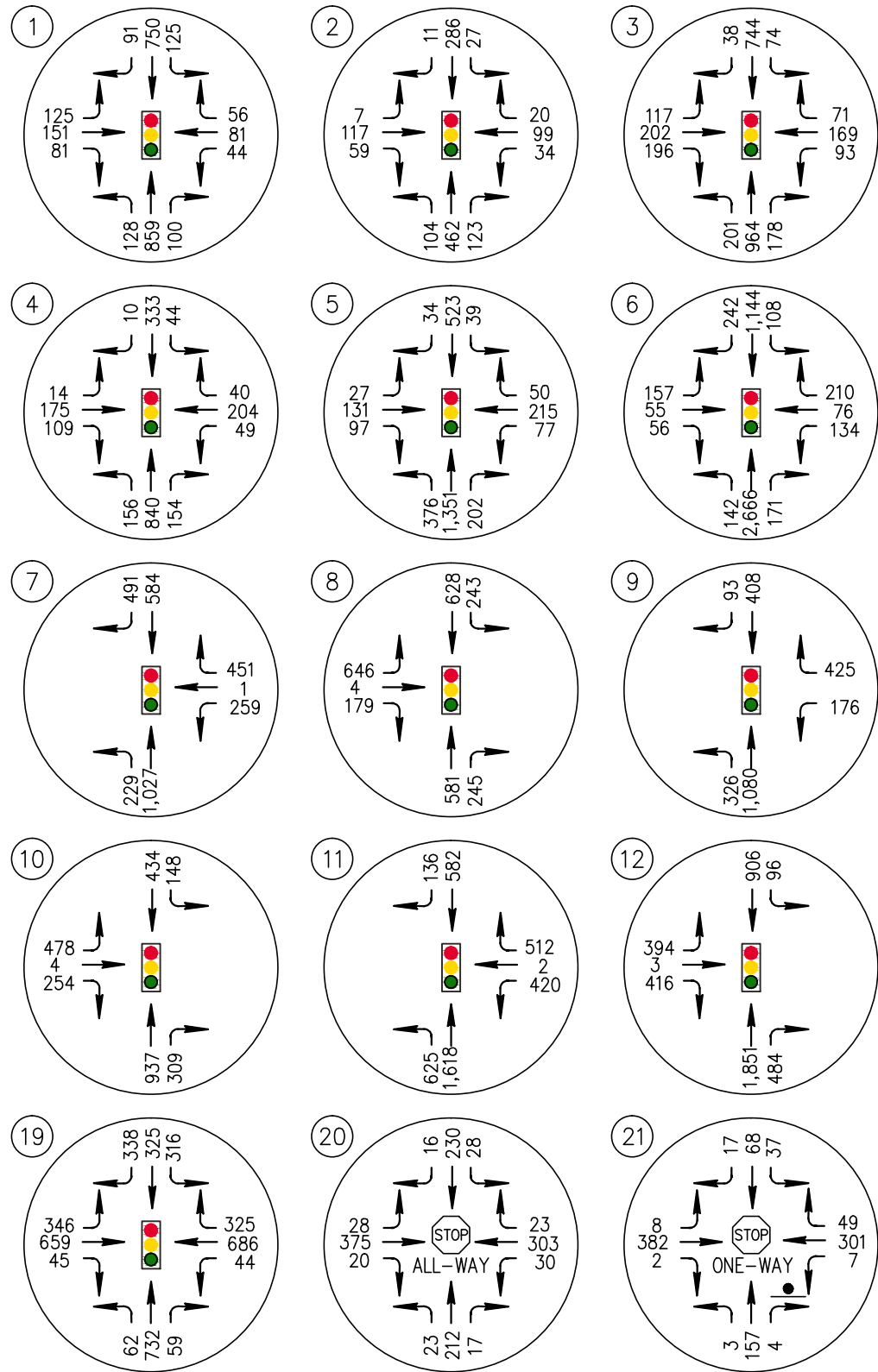

PREPARED BY:



**ARMSTRONG RANCH
TRAFFIC IMPACT STUDY
ONTARIO, CA**

**FIGURE 34A
PHASE 3 BASELINE 2021 WITH PROJECT
AM PEAK HOUR STUDY TRAFFIC VOLUMES**

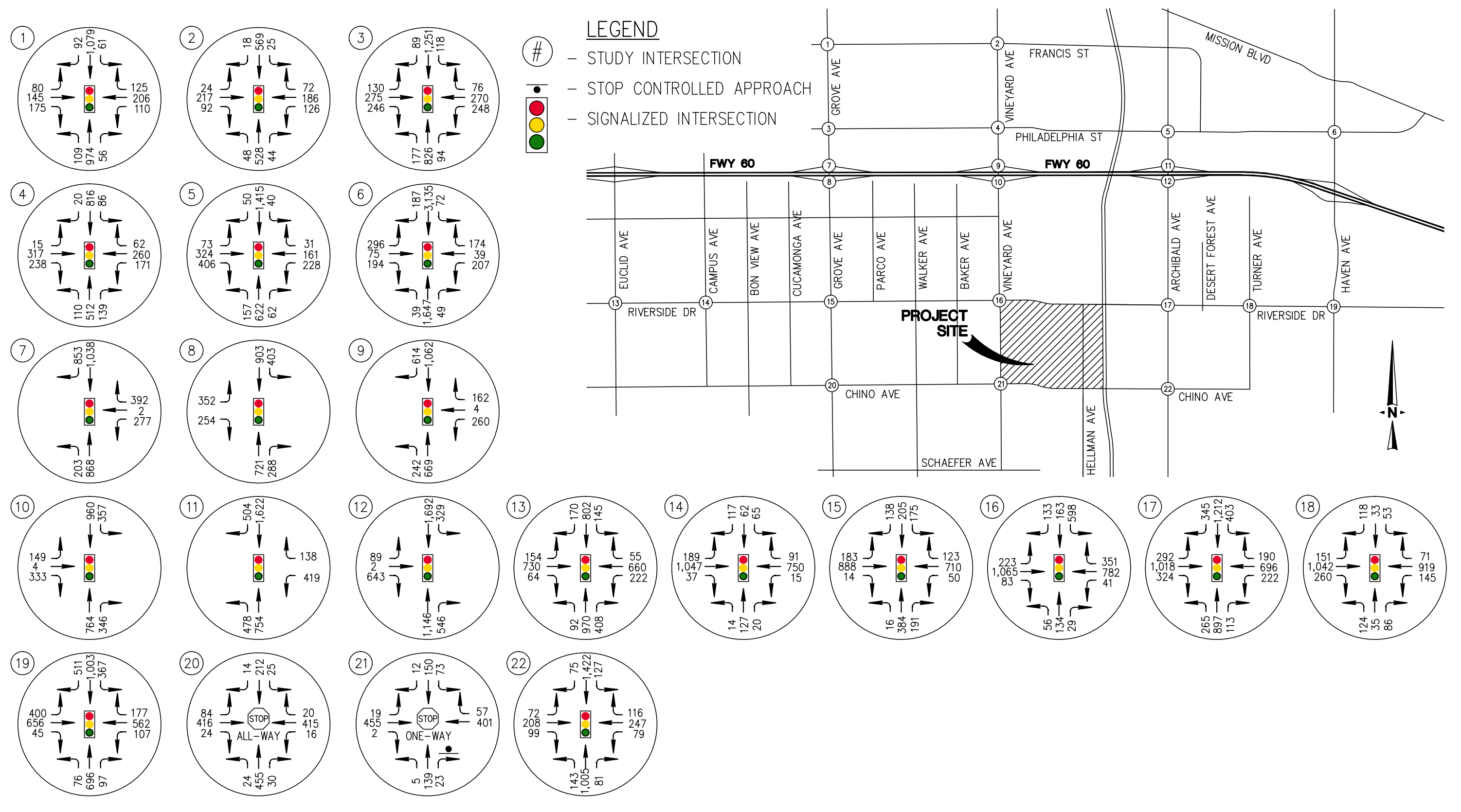

PREPARED BY:



**ARMSTRONG RANCH
TRAFFIC IMPACT STUDY
ONTARIO, CA**

**FIGURE 34B
PHASE 3 BASELINE 2021 WITH PROJECT
PM PEAK HOUR STUDY AREA TRAFFIC VOLUMES**

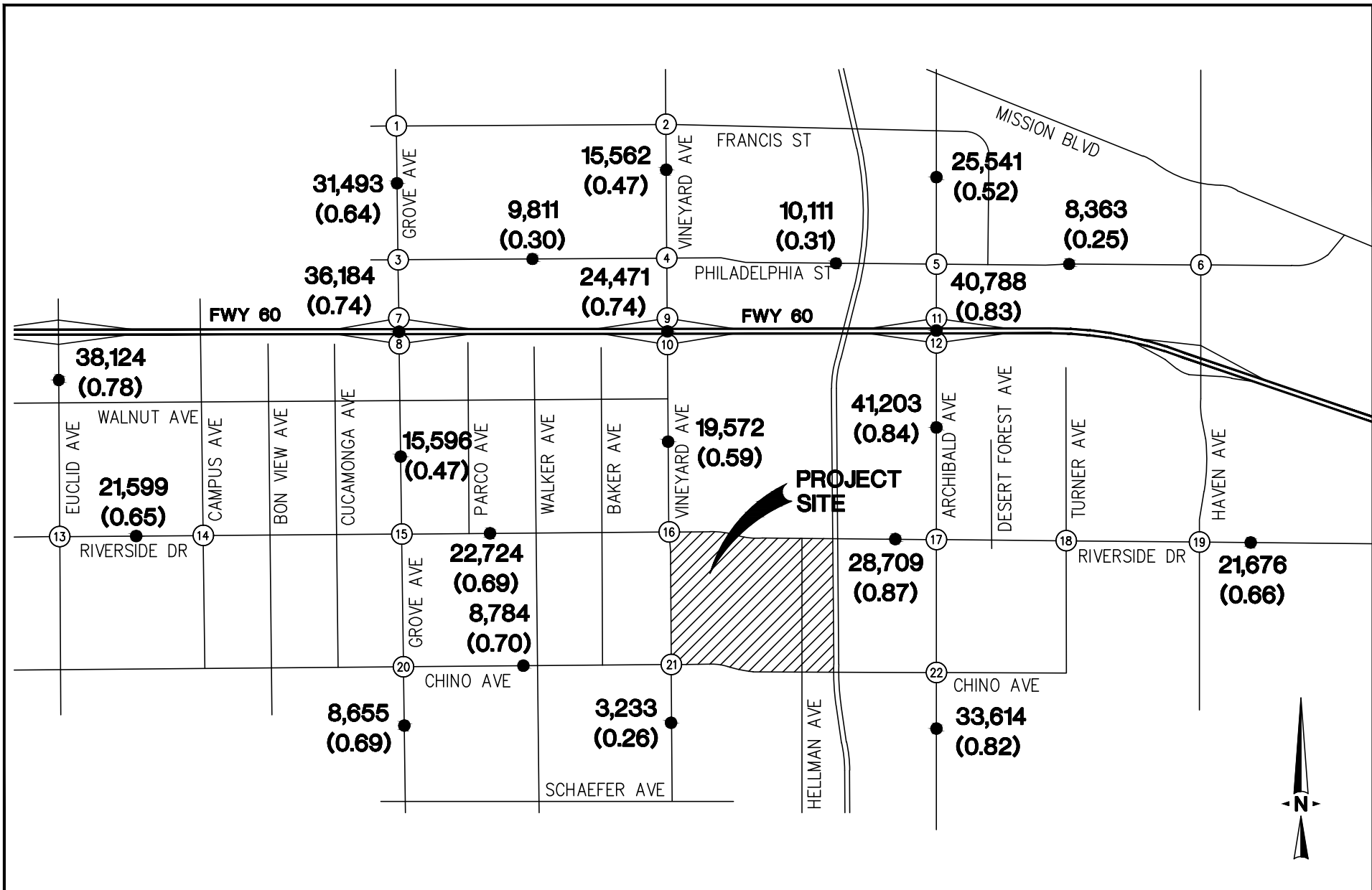

PREPARED BY:



**ARMSTRONG RANCH
TRAFFIC IMPACT STUDY
ONTARIO, CA**

**FIGURE 35
PHASE 3 BASELINE 2021 WITH PROJECT
WEEKDAY DAILY STUDY AREA TRAFFIC VOLUMES**

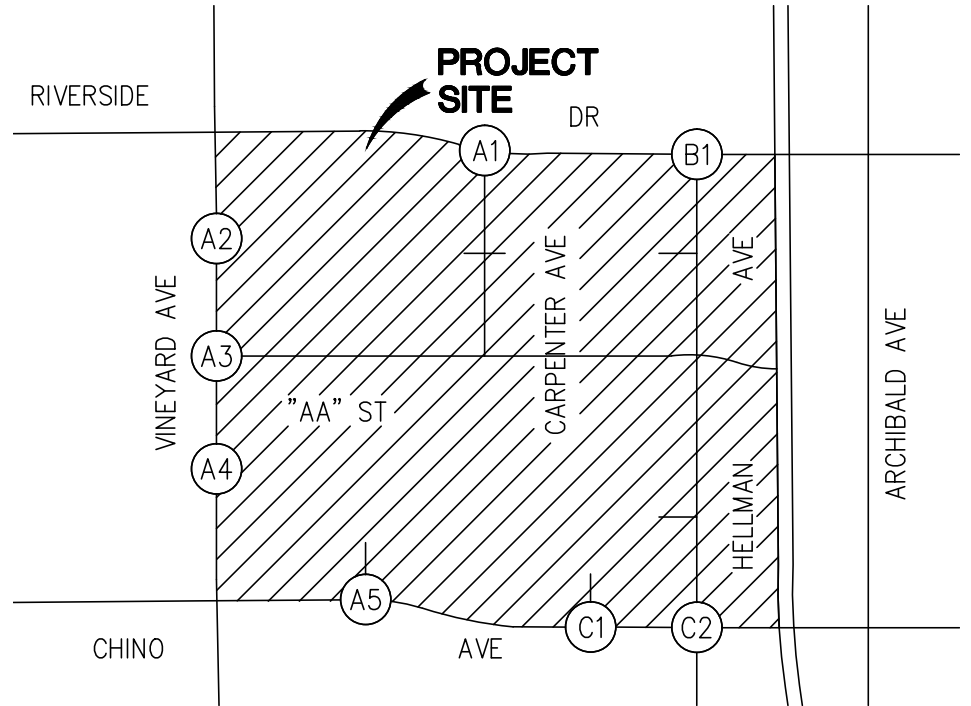
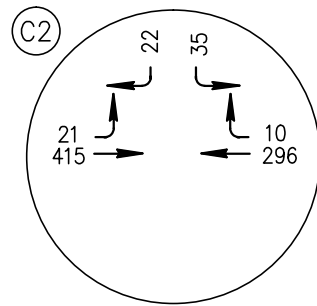
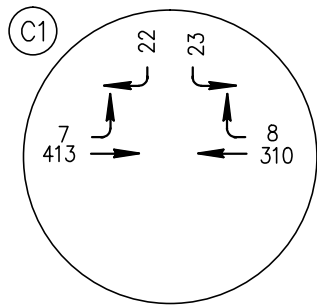
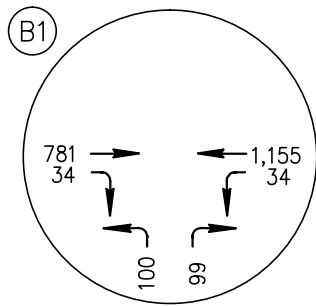
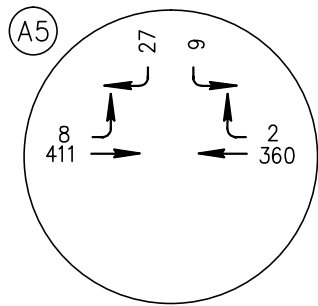
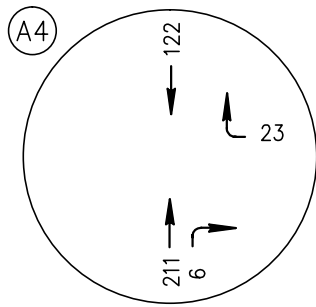
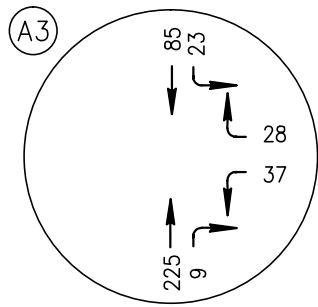
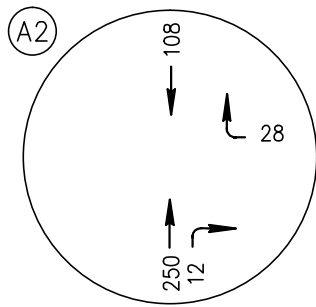
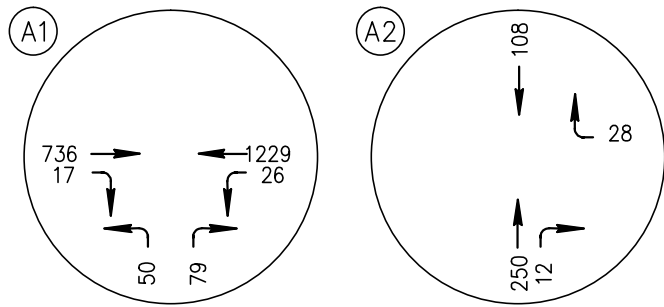

PREPARED BY:



**ARMSTRONG RANCH
TRAFFIC IMPACT STUDY
ONTARIO, CA**

**FIGURE 36A
PHASE 3 BASELINE 2021 WITH PROJECT
AM PEAK HOUR ACCESS INTERSECTION VOLUMES**

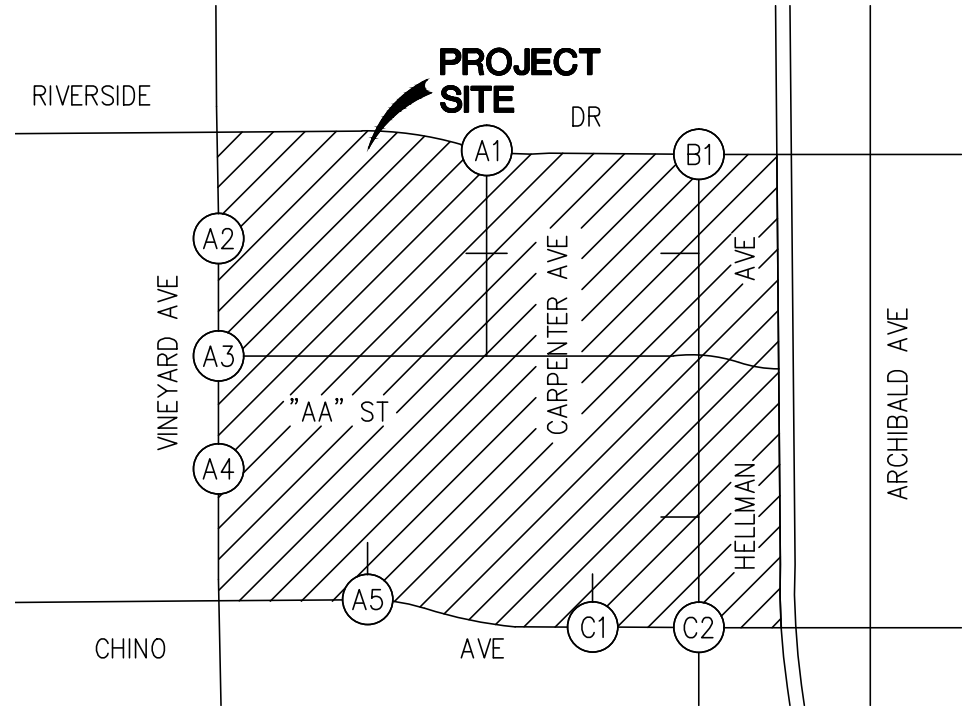
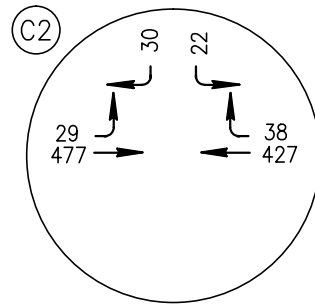
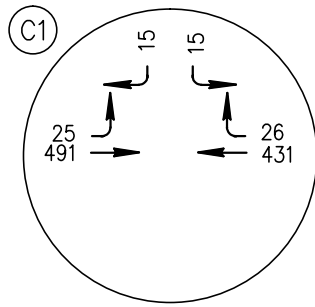
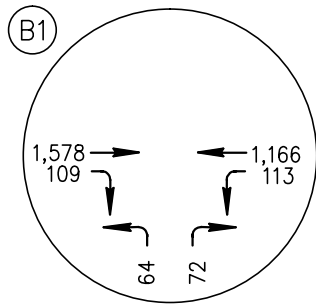
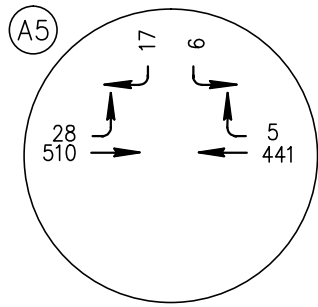
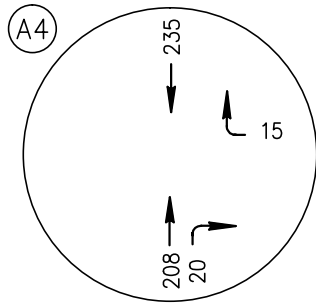
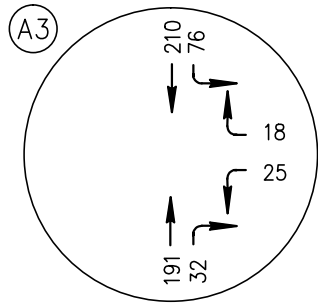
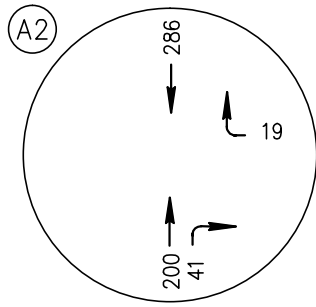
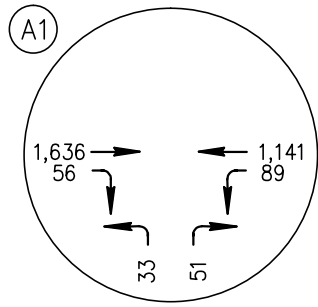

PREPARED BY:



**ARMSTRONG RANCH
TRAFFIC IMPACT STUDY
ONTARIO, CA**

**FIGURE 36B
PHASE 3 BASELINE 2021 WITH PROJECT
PM PEAK HOUR ACCESS INTERSECTION VOLUMES**

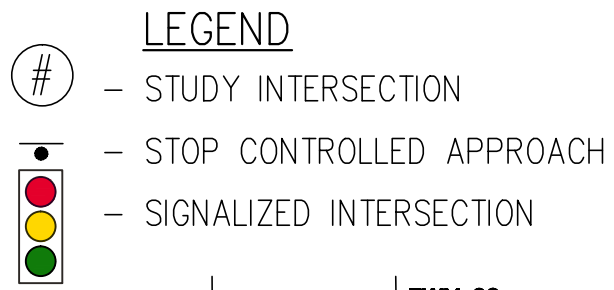
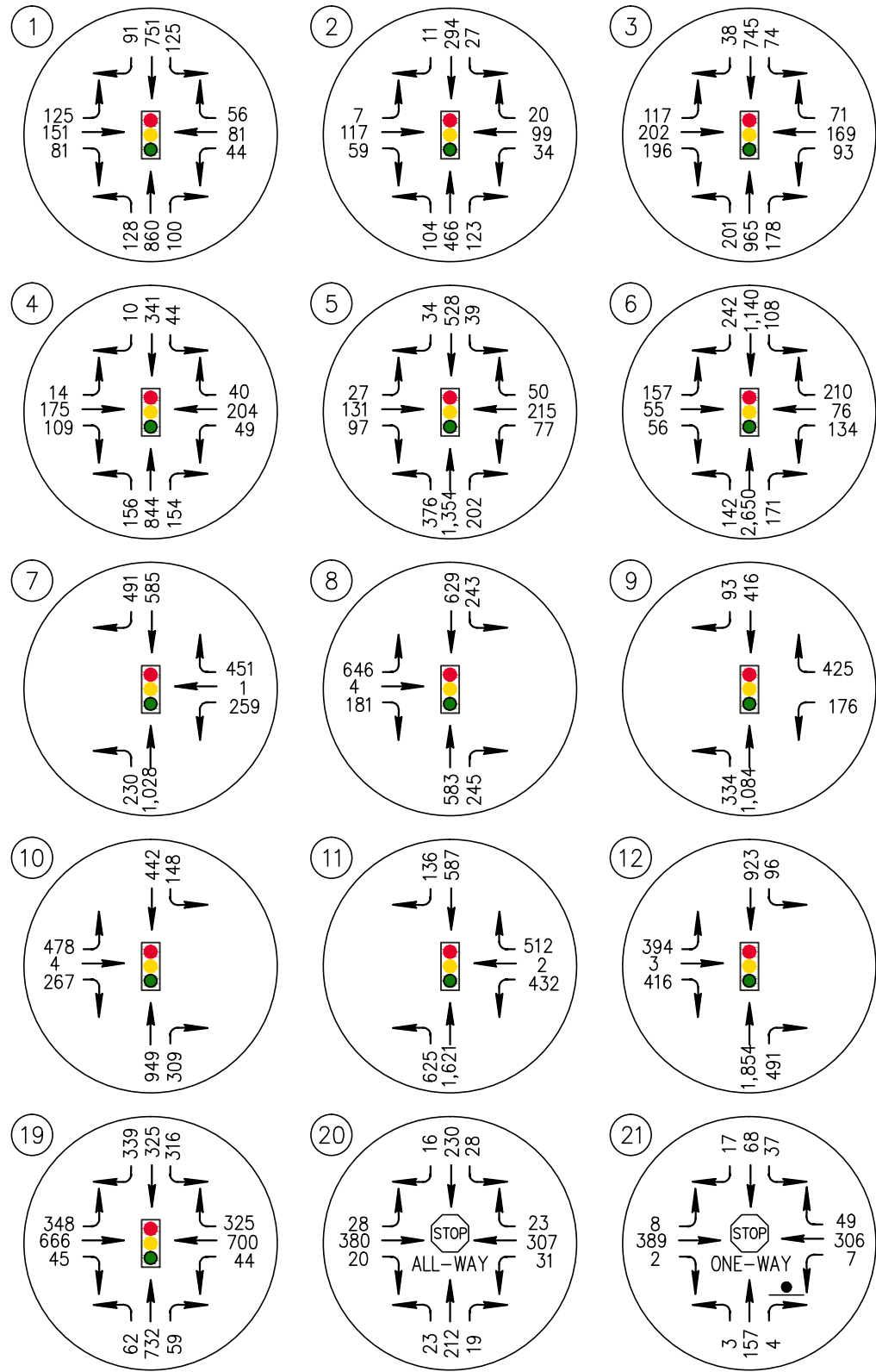

PREPARED BY:



**ARMSTRONG RANCH
TRAFFIC IMPACT STUDY
ONTARIO, CA**

**FIGURE 37A
PHASE 3 BASELINE 2021 WITH PROJECT (WITH SCHOOL)
AM PEAK HOUR STUDY AREA TRAFFIC VOLUMES**

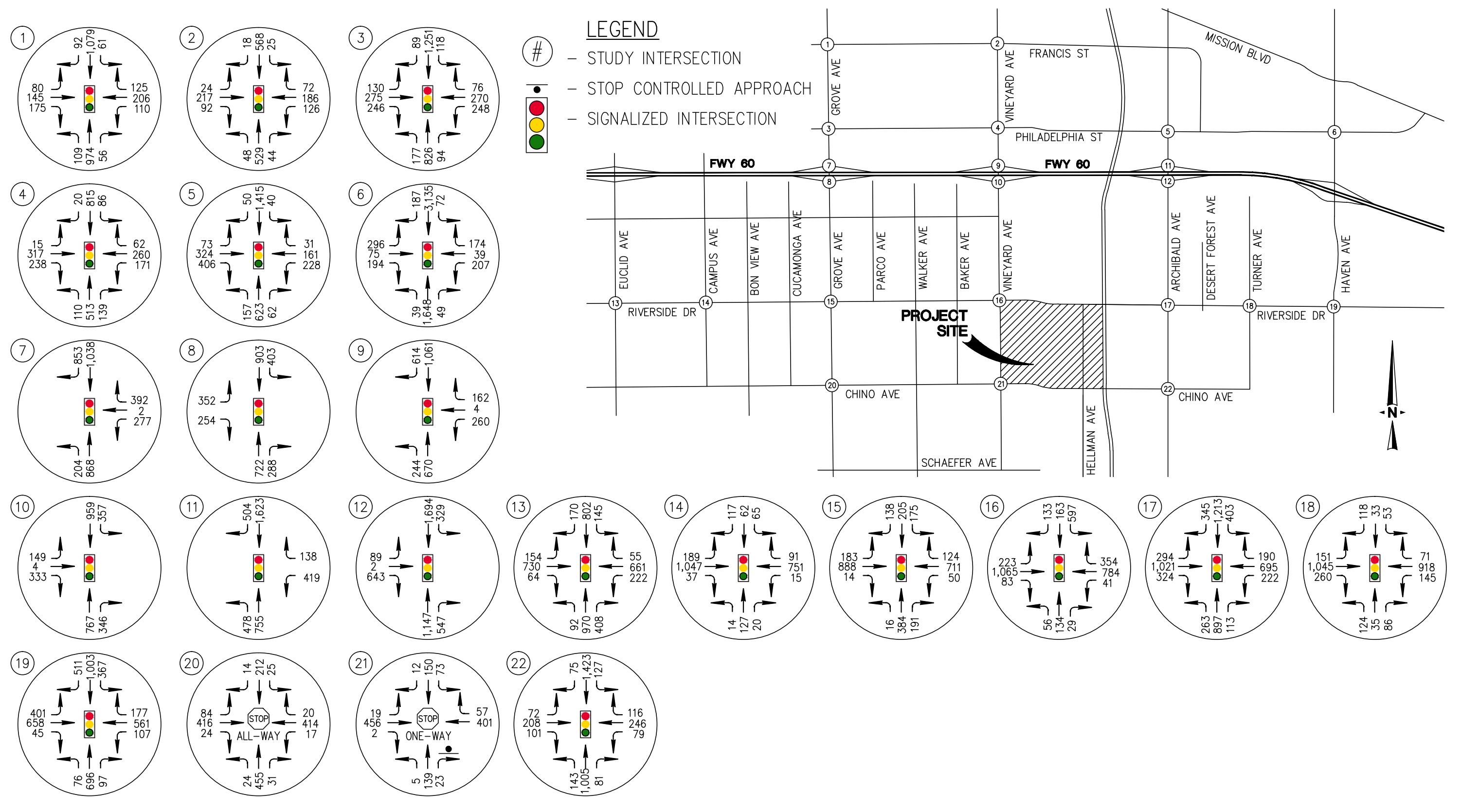

PREPARED BY:



**ARMSTRONG RANCH
TRAFFIC IMPACT STUDY
ONTARIO, CA**

**FIGURE 37B
PHASE 3 BASELINE 2021 WITH PROJECT (WITH SCHOOL)
PM PEAK HOUR STUDY AREA TRAFFIC VOLUMES**

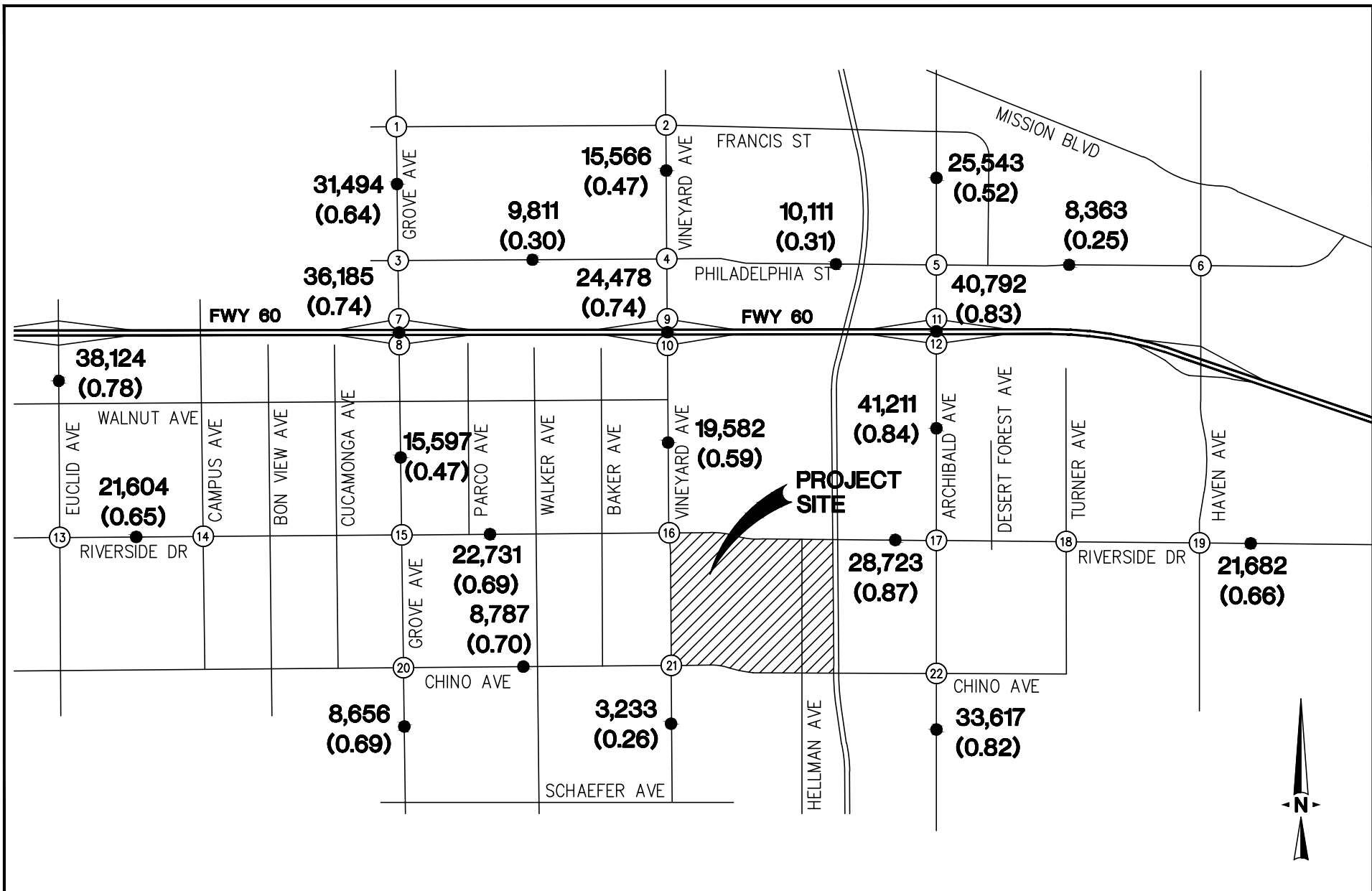

PREPARED BY:



**ARMSTRONG RANCH
TRAFFIC IMPACT STUDY
ONTARIO, CA**

FIGURE 38

**PHASE 3 BASELINE 2021 WITH PROJECT (WITH SCHOOL)
WEEKDAY DAILY STUDY AREA TRAFFIC VOLUMES**

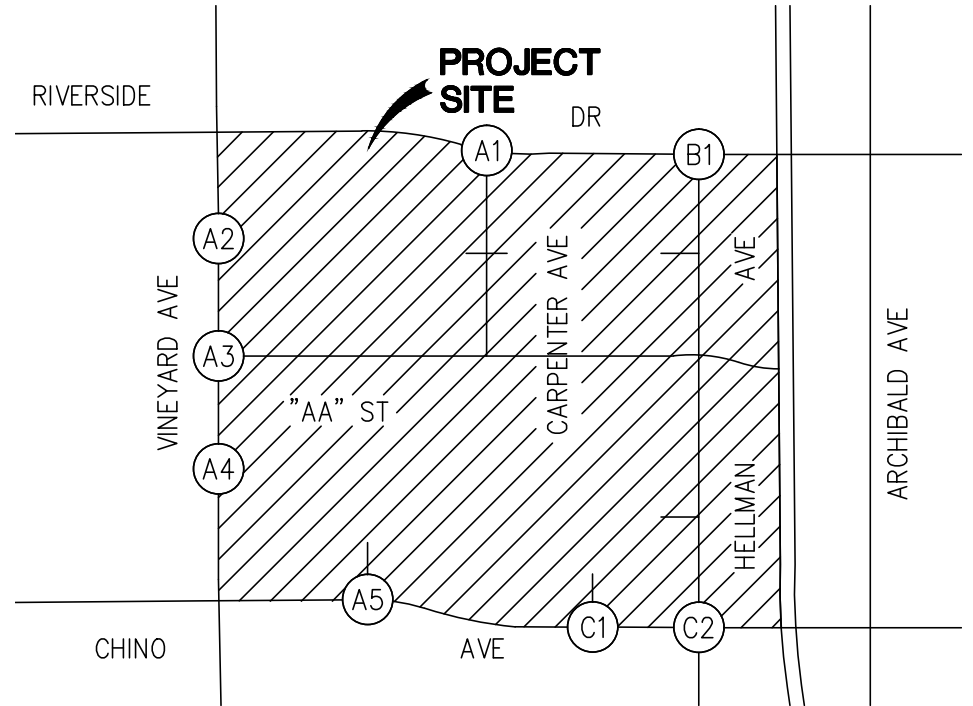
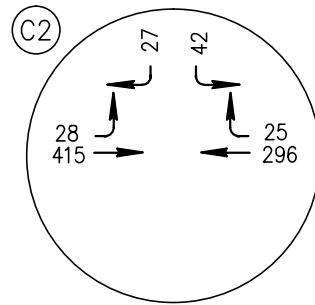
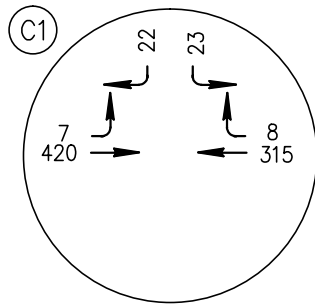
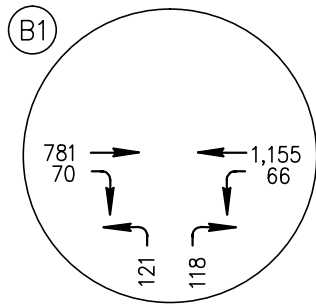
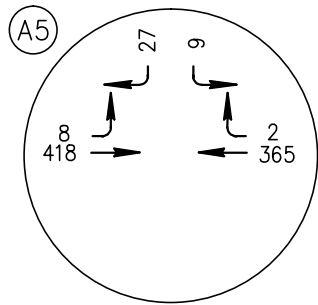
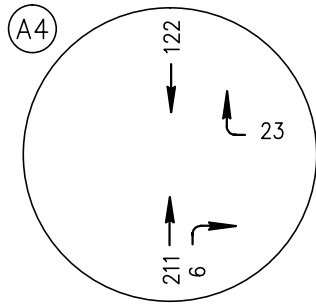
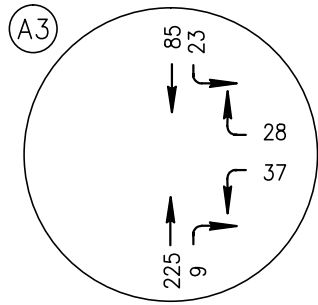
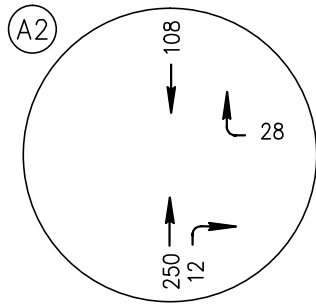
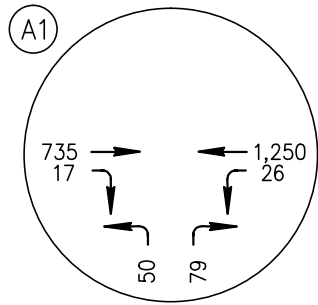

PREPARED BY:



**ARMSTRONG RANCH
TRAFFIC IMPACT STUDY
ONTARIO, CA**

**FIGURE 39A
PHASE 3 BASELINE 2021 WITH PROJECT
(WITH SCHOOL) AM PEAK HOUR
ACCESS INTERSECTION VOLUMES**

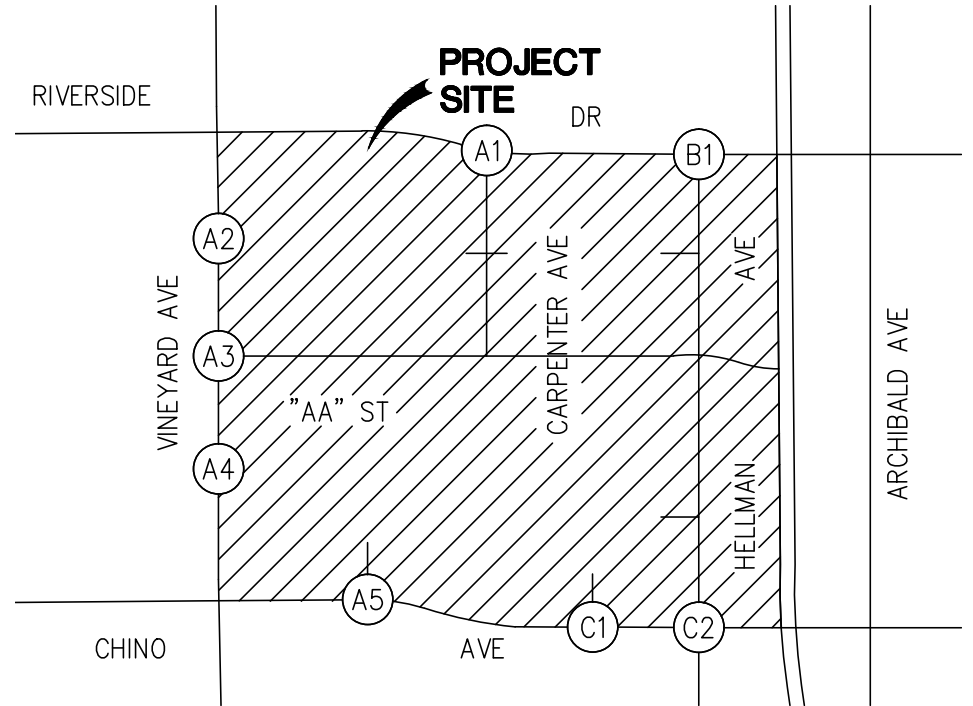
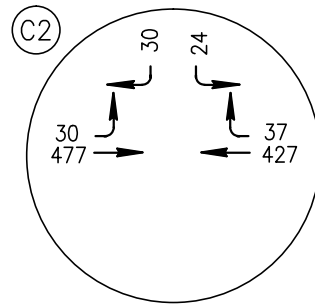
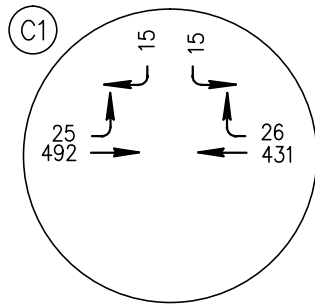
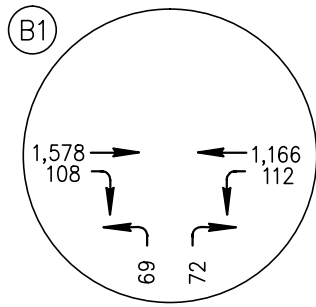
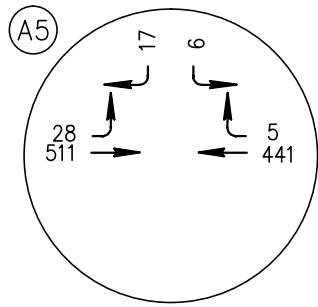
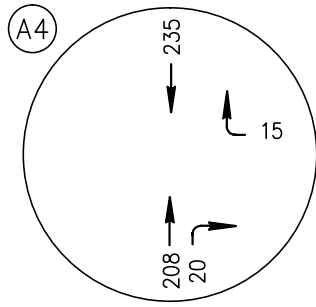
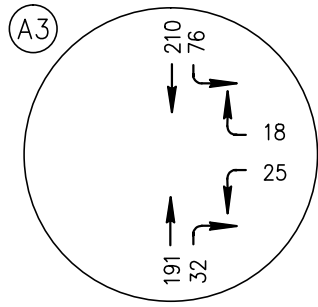
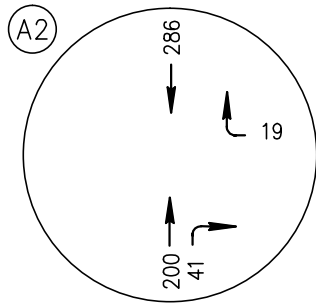
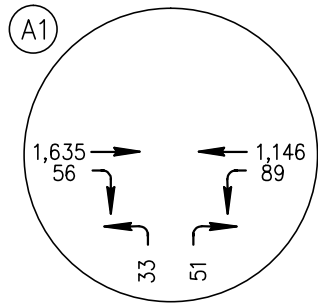

PREPARED BY:



**ARMSTRONG RANCH
TRAFFIC IMPACT STUDY
ONTARIO, CA**

**FIGURE 39B
PHASE 3 BASELINE 2021 WITH PROJECT
(WITH SCHOOL) PM PEAK HOUR
ACCESS INTERSECTION VOLUMES**

AM PEAK HOUR

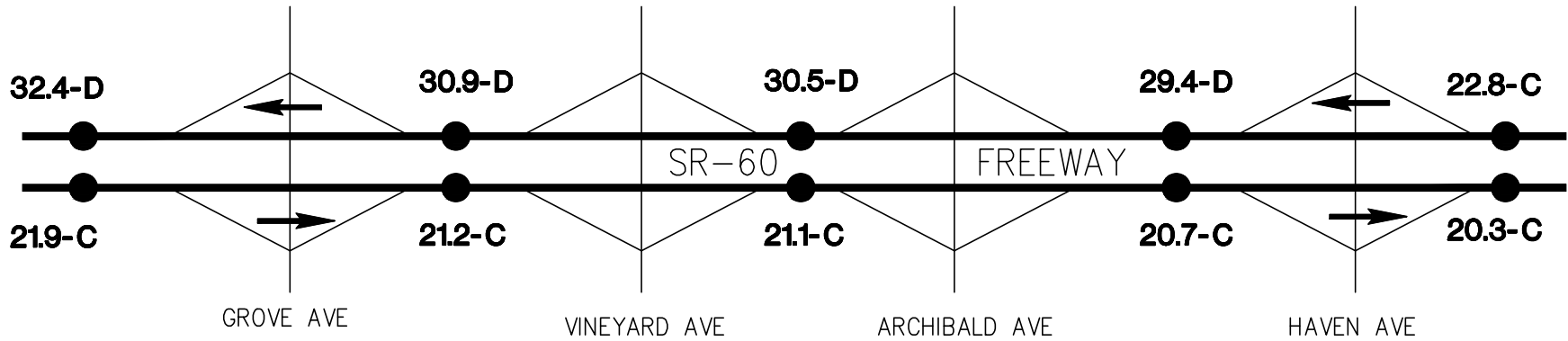

PM PEAK HOUR

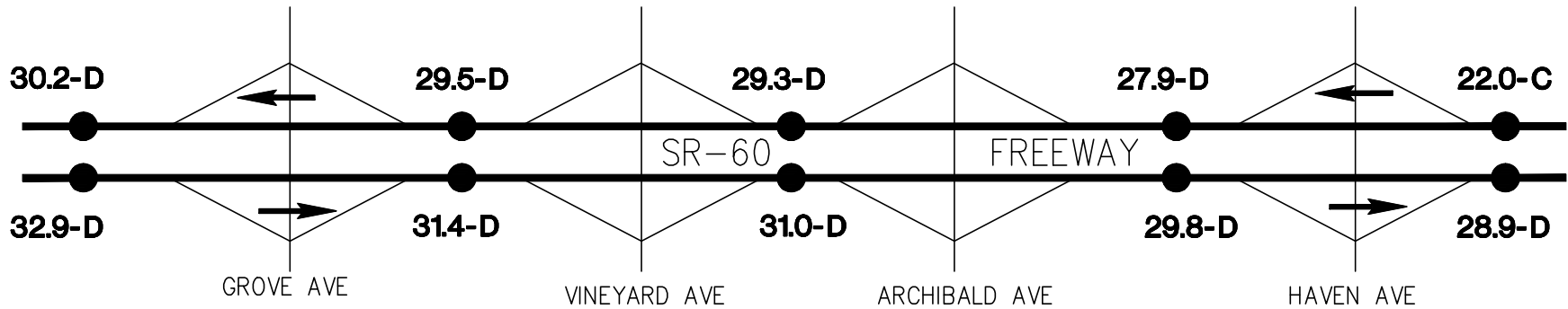

17.2 - PASSENGER CARS PER MILE PER LANE (PCPMPL)
 C - LOS

PREPARED BY:



**ARMSTRONG RANCH
 TRAFFIC IMPACT STUDY
 ONTARIO, CA**

**FIGURE 40
 BASELINE 2021 WITH PROJECT (WITH SCHOOL)
 SR-60 MAINLINE LEVEL OF SERVICE (LOS)**

SECTION IV TRAFFIC ANALYSIS

Baseline with Project traffic volumes as shown on Figures 28A through 39B were analyzed to determine phasing of roadway and intersection infrastructure improvements for each Project phase year and to confirm provided LOS. Roadway segment LOS was determined based on volume-to-capacity (v/c) analysis using City General Plan capacities for each roadway type. Intersection LOS was determined using the 2000 Highway Capacity Manual (HCM) signalized/unsignalized operational methods. The target level of service to be maintained throughout the project study area has been established by the City as Level of Service D for roadways and Level of Service E for intersections.

A.1 Project Phase 1 Baseline (2017) with Project Traffic Conditions

Table 7 shows that for forecast Phase 1 Baseline 2017 with Project conditions the following signalized intersections are predicted to operate at LOS F in at least one peak hour:

Intersection	Am Peak Hour		Pm Peak Hour	
	Delay (s)	LOS	Delay (s)	LOS
16. Vineyard Avenue/Riverside Drive	36.1	D	83.6	F
17. Archibald Avenue/Riverside Drive	56.1	E	97.5	F
19. Haven Avenue/Riverside Drive	458.5	F	531.5	F

Recommended intersection mitigation measures that will return these intersections to acceptable LOS are identified on Table 11 and an analysis of the Armstrong Ranch Project fair share contribution to each mitigation measure is provided on Table 12. With implementation of the recommended project mitigation measures, the LOS at each deficient intersection identified above is predicted to improve as follows:

Intersection (with Mitigation)	Am Peak Hour		Pm Peak Hour	
	Delay (s)	LOS	Delay (s)	LOS
16. Vineyard Avenue/Riverside Drive	39.6	D	30.1	C
17. Archibald Avenue/Riverside Drive	32.1	C	51.1	D
19. Haven Avenue/Riverside Drive	59.9	E	63.5	E
20. Grove Ave/Chino Ave	11.7	B	14.5	B
21. Vineyard Ave/Chino Ave	13.1	B	10.4	B

The stop-controlled Grove Avenue/Chino Avenue intersection is predicted to operate at overflow LOS F conditions in both the am and pm peak hours and the Vineyard Avenue/Chino Avenue stop-controlled intersection is predicted to operate at overflow LOS F during the am peak hour and LOS F during the pm peak hour. Signalization of each of these intersections is warranted under 2017 volume conditions and implementation will provide acceptable LOS at each location as shown above. Table 12 identifies the Armstrong Ranch Project fair share contribution towards providing signalization at each intersection.

All on-site intersections are forecast to operate at acceptable LOS with stop-control under Phase 1 Baseline (2017) with Project Traffic Conditions.

Figure 18 shows that study area roadway segments will have volume-to-capacity ratios of 0.90 or below indicating LOS D or better operation based on Phase 1 Baseline 2017 with Project 24-hour volumes.

A.2 Project Phase 2 Baseline (2019) with Project Traffic Conditions

Table 8 shows that for forecast Phase 2 Baseline 2019 with Project conditions all off-site signalized intersections are predicted to continue to operate at LOS E or above in both peak hours with implementation of the recommended Phase 1 mitigation measures shown on Table 11.

With Phase 2 Baseline (2019) with Project conditions the following on-site intersections are recommended to be signalized:

- A1. Carpenter Avenue and Riverside Drive
- B1. Hellman Avenue and Riverside Drive

The Carpenter Avenue and Riverside Avenue intersection LOS is predicted to become LOS F in the pm peak hour. The forecast volumes at this intersection satisfy signal warrants and signalization will restore acceptable LOS at the intersections as shown below. The Hellman Avenue and Riverside Drive intersection is close to satisfying signal warrants during this phase, but is predicted to not do so until Phase 3. However, without signalization, the intersection does not meet LOS criteria, and therefore, it is recommended that this intersection be signalized as part of Phase 2 improvements.

Intersection (with Mitigation)	Am Peak Hour		Pm Peak Hour	
	Delay (s)	LOS	Delay (s)	LOS
A1. Carpenter Ave/Riverside Drive	4.1	A	2.9	A
B1. Hellman Avenue/Riverside Drive	2.9	A	2.2	A

A.3 Project Phase 3 Baseline (2021) with Project (without school) Traffic Conditions

Table 9 shows that for forecast Phase 3 Baseline 2021 with Project (without school) conditions and with implementation of Phase 1 mitigation measures, only the following off-site signalized intersection is predicted to operate at LOS F during the pm peak hour:

Intersection	Am Peak Hour		Pm Peak Hour	
	Delay (s)	LOS	Delay (s)	LOS
13. Euclid Avenue/Riverside Drive	45.3	D	83.1	F

With implementation of the recommended mitigation for this intersection as shown on Table 11 the LOS at this intersection will improve as shown below:

Intersection (with Mitigation)	Am Peak Hour		Pm Peak Hour	
	Delay (s)	LOS	Delay (s)	LOS
13. Euclid Avenue/Riverside Drive	38.0	D	64.8	E

A.4 Project Phase 3 Baseline (2021) with Project (with school) Traffic Conditions

Table 10 shows that for forecast Phase 3 Baseline 2021 with Project (with school) conditions and with implementation of Phase 1 mitigation measures, only the following off-site signalized intersection is predicted to operate at LOS F during the pm peak hour:

Intersection	Am Peak Hour		Pm Peak Hour	
	Delay (s)	LOS	Delay (s)	LOS
13. Euclid Avenue/Riverside Drive	46.4	D	83.7	F

With implementation of the recommended mitigation for this intersection as shown on Table 11 the LOS at this intersection will improve as shown below:

Intersection (with Mitigation)	Am Peak Hour		Pm Peak Hour	
	Delay (s)	LOS	Delay (s)	LOS
13. Euclid Avenue/Riverside Drive	38.9	D	65.3	E

A.5 Project Phase 3 (2021) without Elementary School On-site Traffic Conditions

The project Phase 3 on-site intersection volumes shown on Figures 23A and 23B were analyzed to identify intersection control and LOS for site build-out conditions for the without elementary school scenario. The results of this analysis are shown on Table A.5-1. This table shows that all of the on-site intersections analyzed are predicted to operate at LOS B or better under Project build-out peak hour conditions (without elementary school) and stop-control. No traffic signal warrants were satisfied for these intersections. Peak hour traffic signal warrants are included in the appendices.

**Table A.5-1 Project Phase 3 (2021) On-site Build-out Intersection Conditions
(without Elementary School)**

Intersection (STOP – control)	Am Peak Hour		Pm Peak Hour	
	Delay (s)	LOS	Delay (s)	LOS
A6. Carpenter Ave/"A" and "C" St (2-way)	9.6	A	10.2	B
A7. Carpenter Ave/"AA" Street (1-way)	8.7	A	8.9	A
A8. "A" Street/"AA" Street (1-way)	8.9	A	9.2	A
B2. Hellman Ave/"C" Street (north) (2-way)	10.0	B	11.1	B
B3. Hellman Ave/"C" Street (south) (2-way)	9.7	A	10.4	B
C3. Hellman Ave/"B" Street (2-way)	9.3	A	9.8	A

A.6 Project Phase 3 (2021) with Elementary School On-site Traffic Conditions

The project Phase 3 on-site intersection volumes shown on Figures 26A and 26B were analyzed to identify intersection control and LOS for site build-out conditions for the with elementary school scenario. The results of this analysis are shown on Table A.5-2. This table shows that all on-site intersections analyzed are predicted to operate at LOS B or better under Project build-out peak hour conditions (with elementary school) and stop-control. No traffic signal warrants were satisfied for these intersections. Peak hour traffic signal warrants are included in the appendices.

**Table A.6-1 Project Phase 3 (2021) On-site Build-out Intersection Conditions
(with Elementary School)**

Intersection (STOP – control)	Am Peak Hour		Pm Peak Hour	
	Delay (s)	LOS	Delay (s)	LOS
A6. Carpenter Ave/"A" and "C" St (2-way)	9.6	A	10.2	B
A7. Carpenter Ave/"AA" Street (1-way)	8.7	A	8.9	A
A8. "A" Street/"AA" Street (1-way)	8.9	A	9.2	A
B2. Hellman Ave/"C" Street (north) (2-way)	11.0	B	11.2	B
B3. Hellman Ave/"C" Street (south) (2-way)	11.3	B	10.3	A
C3. Hellman Ave/"B" Street (2-way)	9.5	A	9.8	A

A.7 SR-60 Freeway Mainline Analysis for Phase 3 Baseline 2021 with Project Conditions

Figure 38C provides a summary of mainline LOS analysis for the SR-60 Freeway with Phase 3 Baseline 2021 with Project (with elementary school) peak hour volumes. This scenario represents the worst case for contributing traffic volumes to the SR-60 mainline. All other project phase years result in fewer volumes being assigned to the freeway and therefore would have even less impact. Figure 38C shows that all SR-60 study segments will continue to operate at LOS D or C with worst case 2021 Baseline and Phase 3 Project build-out volumes. The freeway mainline LOS calculations are included in the appendices.



TABLE 7
Phase 1 Baseline 2017 Level of Service at Study Area Intersections

Signalized Intersection	Phase 1 - 2017 Baseline				Phase 1 - 2017 Baseline plus Project			
	AM Peak Hour		PM Peak Hour		AM Peak Hour		PM Peak Hour	
	Delay (sec.)	LOS	Delay (sec.)	LOS	Delay (sec.)	LOS	Delay (sec.)	LOS
1. Grove Ave/Francis St	17.3	B	19.1	B	17.2	B	19.1	B
2. Vineyard Ave/Francis St	14.1	B	17.1	B	13.9	B	17.1	B
3. Grove Ave/Philadelphia St	18.0	B	30.8	C	18.0	B	30.9	C
4. Vineyard Ave/Philadelphia St	17.2	B	23.3	C	17.2	B	23.5	C
5. Archibald Ave/Philadelphia St	14.5	B	31.9	C	14.5	B	32.0	C
6. Haven Ave/Philadelphia St	30.0	C	24.6	C	30.2	C	23.9	C
7. Grove Ave/Fwy 60 WB Ramp	18.2	B	32.4	C	18.3	B	32.6	C
8. Grove Ave/Fwy 60 EB Ramp	31.9	C	24.2	C	32.2	C	24.3	C
9. Vineyard Ave/Fwy 60 WB Ramp	17.5	B	21.6	C	17.7	B	23.8	C
10. Vineyard Ave/Fwy 60 EB Ramp	26.6	C	14.7	B	28.2	C	20.9	C
11. Archibald Ave/Fwy 60 WB Ramp	35.8	D	32.0	C	35.9	D	37.2	D
12. Archibald Ave/Fwy 60 EB Ramp	22.5	C	55.0	D	23.2	C	57.0	E
13. Euclid Ave/Riverside Dr	41.4	D	67.2	E	39.9	D	67.4	E
14. Campus Ave/Riverside Dr	19.4	B	17.0	B	19.5	B	17.5	B
15. Grove Ave/Riverside Dr	18.5	B	46.7	D	18.7	B	42.8	D
16. Vineyard Ave/Riverside Dr	45.4	D	137.4	F	36.1	D	83.6	F
17. Archibald Ave/Riverside Dr	49.3	D	93.0	F	56.1	E	97.5	F
18. Turner Ave/Riverside Dr	21.7	C	16.3	B	21.9	C	16.3	B
19. Haven Ave/Riverside Dr	453.0	F	526.4	F	458.5	F	531.5	F
22. Archibald Ave/Chino Ave	23.8	C	20.2	C	24.3	C	21.4	C
Unsignalized Intersection	Phase 1 - 2017 Baseline				Phase 1 - 2017 Baseline plus Project			
	AM Peak Hour		PM Peak Hour		AM Peak Hour		PM Peak Hour	
	Delay (sec.)	LOS	Delay (sec.)	LOS	Delay (sec.)	LOS	Delay (sec.)	LOS
20. Grove Ave/Chino Ave	OVERFLOW	F	OVERFLOW	F	OVERFLOW	F	OVERFLOW	F
21. Vineyard Ave/Chino Ave	299.0	F	92.8	F	OVERFLOW	F	241.0	F
A1. Carpenter Ave / East Riverside Dr	-	-	-	-	15.7	C	43.0	E
A2. Vineyard Ave / "B" St (North)	-	-	-	-	9.6	A	9.4	A
A3. Vineyard Ave / "AA" St	-	-	-	-	10.0	B	10.9	B
A4. Vineyard Ave / "B" St (South)	-	-	-	-	9.3	A	9.2	A
A5. "A" St (West) / Chino Ave	-	-	-	-	11.1	B	12.6	B

V:\2065\active\2065000200\surmap\Eng\TechDocs\Reports\01 Traffic Study\02 Tables\REV. with CO-Watson Ind Added as Extra Cumul\Table 9 & 10- Baseline 2021 (elementary) project LOS .xls\TABLE 9



TABLE 8
Baseline 2019 with Project - Study Area Intersection Level of Service

Signalized Intersection	Phase 2 - 2019 Baseline				Phase 2 - 2019 Baseline plus Project			
	AM Peak Hour		PM Peak Hour		AM Peak Hour		PM Peak Hour	
	Delay (sec.)	LOS	Delay (sec.)	LOS	Delay (sec.)	LOS	Delay (sec.)	LOS
1. Grove Ave/Francis St	17.4	B	19.3	B	17.4	B	19.3	B
2. Vineyard Ave/Francis St	14.1	B	17.3	B	13.8	B	17.2	B
3. Grove Ave/Philadelphia St	18.2	B	32.4	C	18.2	B	32.6	C
4. Vineyard Ave/Philadelphia St	17.4	B	23.9	C	17.4	B	24.4	C
5. Archibald Ave/Philadelphia St	14.6	B	34.8	C	14.6	B	33.5	C
6. Haven Ave/Philadelphia St	32.7	C	25.8	C	26.3	C	24.8	C
7. Grove Ave/Fwy 60 WB Ramp	18.7	B	34.7	C	19.0	B	35.1	D
8. Grove Ave/Fwy 60 EB Ramp	34.3	C	25.5	C	34.9	C	25.9	C
9. Vineyard Ave/Fwy 60 WB Ramp	17.6	B	23.1	C	18.2	B	28.3	C
10. Vineyard Ave/Fwy 60 EB Ramp	28.3	C	19.4	B	32.2	C	24.8	C
11. Archibald Ave/Fwy 60 WB Ramp	38.5	D	36.7	D	38.7	D	48.7	D
12. Archibald Ave/Fwy 60 EB Ramp	24.3	C	60.1	E	26.2	C	64.7	E
13. Euclid Ave/Riverside Dr	41.8	D	68.7	E	42.8	D	75.4	E
14. Campus Ave/Riverside Dr	19.8	B	17.6	B	20.0	C	18.8	B
15. Grove Ave/Riverside Dr	18.9	B	52.8	D	19.2	B	48.2	D
16. Vineyard Ave/Riverside Dr	47.7	D	139.3	F	44.7	D	33.3	C
17. Archibald Ave/Riverside Dr	53.0	D	98.8	F	35.3	D	59.7	E
18. Turner Ave/Riverside Dr	22.4	C	16.5	B	22.7	C	16.6	B
19. Haven Ave/Riverside Dr	458.0	F	526.2	F	62.3	E	65.9	E
20. Grove Ave/Chino Ave	-	-	-	-	11.8	B	14.8	B
21. Vineyard Ave/Chino Ave	-	-	-	-	13.0	B	10.4	B
22. Archibald Ave/Chino Ave	24.9	C	20.8	C	26.1	C	22.9	C

Unsignalized Intersection	Phase 2 - 2019 Baseline				Phase 2 - 2019 Baseline plus Project			
	AM Peak Hour		PM Peak Hour		AM Peak Hour		PM Peak Hour	
	Delay (sec.)	LOS	Delay (sec.)	LOS	Delay (sec.)	LOS	Delay (sec.)	LOS
20. Grove Ave/Chino Ave	OVERFLOW	F	OVERFLOW	F	-	-	-	-
21. Vineyard Ave/Chino Ave	300.2	F	94.9	F	-	-	-	-
A1. Carpenter Ave / East Riverside Dr	-	-	-	-	23.8	C	184.4	F
A2. Vineyard Ave / "B" St (North)	-	-	-	-	9.6	A	9.4	A
A3. Vineyard Ave / "AA" St	-	-	-	-	10.3	B	11.4	B
A4. Vineyard Ave / "B" St (South)	-	-	-	-	9.4	A	9.4	A
A5. "A" St (West) / Chino Ave	-	-	-	-	11.2	B	12.7	B
B1. Hellman Ave / East Riverside Dr	-	-	-	-	27.1	D	150.6	F

V:\2065\active\2065000200\surmap\Eng\TechDocs\Reports\01 Traffic Study\02 Tables\REV. with CO-Watson Ind Added as Extra Cumul\Table 9 &10- Baseline 2021 (elementary) project LOS .xls\TABLE 9



TABLE 9
Baseline 2021 plus Project Level of Service at Study Area Intersections

Signalized Intersection	Phase 3 - 2021 Baseline				Phase 3 - 2021 Baseline plus Project (Without Elementary)			
	AM Peak Hour		PM Peak Hour		AM Peak Hour		PM Peak Hour	
	Delay (sec.)	LOS	Delay (sec.)	LOS	Delay (sec.)	LOS	Delay (sec.)	LOS
1. Grove Ave/Francis St	17.5	B	19.6	B	17.4	B	19.6	B
2. Vineyard Ave/Francis St	14.2	B	17.3	B	13.7	B	17.2	B
3. Grove Ave/Philadelphia St	18.4	B	33.8	C	18.4	B	34.2	C
4. Vineyard Ave/Philadelphia St	17.5	B	24.4	C	17.5	B	25.4	C
5. Archibald Ave/Philadelphia St	14.6	B	34.4	C	14.7	B	35.0	C
6. Haven Ave/Philadelphia St	35.6	D	25.6	C	27.8	C	25.7	C
7. Grove Ave/Fwy 60 WB Ramp	19.4	B	37.0	D	19.8	B	37.7	D
8. Grove Ave/Fwy 60 EB Ramp	37.2	D	27.3	C	38.4	D	27.9	C
9. Vineyard Ave/Fwy 60 WB Ramp	18.1	B	24.9	C	19.0	B	35.3	D
10. Vineyard Ave/Fwy 60 EB Ramp	30.4	C	20.2	C	38.1	D	31.2	C
11. Archibald Ave/Fwy 60 WB Ramp	41.3	D	39.8	D	41.8	D	60.7	E
12. Archibald Ave/Fwy 60 EB Ramp	25.8	C	63.6	E	29.5	C	70.7	E
13. Euclid Ave/Riverside Dr	47.2	D	72.4	E	45.3	D	83.1	F
14. Campus Ave/Riverside Dr	20.3	C	18.1	B	20.6	C	20.1	C
15. Grove Ave/Riverside Dr	19.3	B	45.0	D	19.9	B	54.2	D
16. Vineyard Ave/Riverside Dr	49.5	D	131.4	F	51.7	D	37.4	D
17. Archibald Ave/Riverside Dr	55.9	E	104.8	F	38.7	D	64.6	E
18. Turner Ave/Riverside Dr	23.1	C	16.8	B	23.7	C	16.9	B
19. Haven Ave/Riverside Dr	463.8	F	528.7	F	65.4	E	69.0	E
20. Grove Ave/Chino Ave	-	-	-	-	11.9	B	15.2	B
21. Vineyard Ave/Chino Ave	-	-	-	-	13.3	B	10.6	B
22. Archibald Ave/Chino Ave	25.8	C	21.2	C	27.4	C	26.0	C
A1. Carpenter Ave / East Riverside Dr	-	-	-	-	3.5	A	2.4	A
B1. Hellman Ave / East Riverside Dr	-	-	-	-	4.5	A	3.6	A
Unsignalized Intersection	Phase 3 - 2021 Baseline				Phase 3 - 2021 Baseline plus Project (Without Elementary)			
	AM Peak Hour		PM Peak Hour		AM Peak Hour		PM Peak Hour	
	Delay (sec.)	LOS	Delay (sec.)	LOS	Delay (sec.)	LOS	Delay (sec.)	LOS
20. Grove Ave/Chino Ave	OVERFLOW	F	OVERFLOW	F	-	-	-	-
21. Vineyard Ave/Chino Ave	302.6	F	96.5	F	-	-	-	-
A2. Vineyard Ave / "B" St (North)	-	-	-	-	10.8	B	9.5	A
A3. Vineyard Ave / "AA" St	-	-	-	-	10.4	B	11.6	B
A4. Vineyard Ave / "B" St (South)	-	-	-	-	9.5	A	9.4	A
A5. "A" St (West) / Chino Ave	-	-	-	-	11.8	B	13.3	B
C1. "A" St (East) / Chino Ave	-	-	-	-	11.1	B	12.7	B
C2. Hellman Ave / Chino Ave	-	-	-	-	11.8	B	12.5	B

V:\2065\active\2065000200\sumap\Eng\TechDocs\Reports\01 Traffic Study\02 Tables\REV. with CO-Watson Ind Added as Extra Cumul\Table 9 & 10- Baseline 2021 (elementary) project LOS .xls\TABLE 9



TABLE 10
Baseline 2021 plus Project Level of Service at Study Area Intersections
With Elementary School

Signalized Intersection	Phase 3 - 2021 Baseline				Phase 3 - 2021 Baseline plus Project (With Elementary)			
	AM Peak Hour		PM Peak Hour		AM Peak Hour		PM Peak Hour	
	Delay (sec.)	LOS	Delay (sec.)	LOS	Delay (sec.)	LOS	Delay (sec.)	LOS
1. Grove Ave/Francis St	17.5	B	19.6	B	17.4	B	19.6	B
2. Vineyard Ave/Francis St	14.2	B	17.3	B	13.7	B	17.2	B
3. Grove Ave/Philadelphia St	18.4	B	33.8	C	18.4	B	34.2	C
4. Vineyard Ave/Philadelphia St	17.5	B	24.4	C	17.5	B	25.4	C
5. Archibald Ave/Philadelphia St	14.6	B	34.4	C	14.7	B	35.0	C
6. Haven Ave/Philadelphia St	35.6	D	25.6	C	27.5	C	25.7	C
7. Grove Ave/Fwy 60 WB Ramp	19.4	B	37.0	D	19.8	B	37.8	D
8. Grove Ave/Fwy 60 EB Ramp	37.2	D	27.3	C	38.4	D	27.9	C
9. Vineyard Ave/Fwy 60 WB Ramp	18.1	B	24.9	C	19.2	B	35.5	D
10. Vineyard Ave/Fwy 60 EB Ramp	30.4	C	20.2	C	38.8	D	31.4	C
11. Archibald Ave/Fwy 60 WB Ramp	41.3	D	39.8	D	42.2	D	60.7	E
12. Archibald Ave/Fwy 60 EB Ramp	25.8	C	63.6	E	30.3	C	70.9	E
13. Euclid Ave/Riverside Dr	47.2	D	72.4	E	46.4	D	83.7	F
14. Campus Ave/Riverside Dr	20.3	C	18.1	B	20.9	C	20.1	C
15. Grove Ave/Riverside Dr	19.3	B	45.0	D	20.1	C	54.2	D
16. Vineyard Ave/Riverside Dr	49.5	D	131.4	F	52.8	D	37.6	D
17. Archibald Ave/Riverside Dr	55.9	E	104.8	F	40.1	D	64.6	E
18. Turner Ave/Riverside Dr	23.1	C	16.8	B	24.0	C	16.9	B
19. Haven Ave/Riverside Dr	463.8	F	528.7	F	66.6	E	70.0	E
20. Grove Ave/Chino Ave	-	-	-	-	11.9	B	15.2	B
21. Vineyard Ave/Chino Ave	-	-	-	-	13.3	B	10.5	B
22. Archibald Ave/Chino Ave	25.8	C	21.2	C	27.9	C	26.2	C
A1. Carpenter Ave / East Riverside Dr	-	-	-	-	4.0	A	2.4	A
B1. Hellman Ave / East Riverside Dr	-	-	-	-	5.8	A	3.5	A

Unsignalized Intersection	Phase 3 - 2021 Baseline				Phase 3 - 2021 Baseline plus Project (With Elementary)			
	AM Peak Hour		PM Peak Hour		AM Peak Hour		PM Peak Hour	
	Delay (sec.)	LOS	Delay (sec.)	LOS	Delay (sec.)	LOS	Delay (sec.)	LOS
20. Grove Ave/Chino Ave	OVERFLOW	F	OVERFLOW	F	-	-	-	-
21. Vineyard Ave/Chino Ave	302.6	F	96.5	F	-	-	-	-
A2. Vineyard Ave / "B" St (North)	-	-	-	-	9.7	B	9.5	A
A3. Vineyard Ave / "AA" St	-	-	-	-	10.4	B	11.6	B
A4. Vineyard Ave / "B" St (South)	-	-	-	-	9.5	A	9.4	A
A5. "A" St (West) / Chino Ave	-	-	-	-	11.9	B	13.3	B
C1. "A" St (East) / Chino Ave	-	-	-	-	11.2	B	12.7	B
C2. Hellman Ave / Chino Ave	-	-	-	-	12.1	B	12.6	B

V:\2065\active\2065000200\sumap\Eng\TechDocs\Reports\01 Traffic Study\02 Tables\REV. with CO-Watson Ind Added as Extra Cumul\Table 9 & 10- Baseline 2021 (elementary) project LOS .xls\TABLE 9

Table 11 – Recommended Project Study Area Mitigation Measures

Intersection	Phase -Year Mitigation Required	Mitigation Measure(s)	Preliminary Opinion of Cost	Comments
13. Euclid Ave/Riverside Dr	Phase 3 - 2021	Add 3 rd NB & SB through lanes	\$250,000	Cost shown assumes no R/W acquisition required
16. Vineyard Ave/Riverside Dr	Phase 1 - 2017	Add 2 nd SBLT	\$5,000	Cost assumes re-striping and minor signal modification only
17. Archibald Ave/Riverside Dr	Phase 1 - 2017	Provide dual left-turns on all approaches	\$550,000	Cost shown assumes no R/W acquisition required
19. Haven Ave/Riverside Dr	Phase 1 - 2017	SB: 1-Rt, 1-thru, 2-lts NB: 1-Lt, 1-thru, 1-thru/rt EB: Add 1-thru, 1-lt WB: Add Rt-turn lane	\$800,000	Cost does not include R/W acquisition, if necessary
20. Grove Ave/Chino Ave	Phase 1 - 2017	Install Traffic Signal	\$400,000	-
21. Vineyard Ave/Chino Ave	Phase 1 - 2017	Install Traffic Signal	\$400,000	-
A1. Carpenter Ave/E. Riverside Dr	Phase 2 - 2019	Install Traffic Signal	\$400,000	-
B1. Hellman Ave/E. Riverside Dr	Phase 2 - 2019	Install Traffic Signal	\$400,000	-

Table 12 – Armstrong Ranch Project Fair Share Analysis¹

Intersection	Cumulative Project Traffic Volumes (C)			Armstrong Ranch Traffic Volumes (AR)			Total Am/Pm Vol. (C+AR)	Armstrong Ranch Fair Share %
	AM Vol.	PM Vol.	Total Vol.	AM Vol.	PM Vol.	Total Vol.		
13. Euclid Ave/Riverside Dr	417	603	1020	116	130	246	1266	19.4%
16. Vineyard Ave/Riverside Dr	552	792	1344	419	482	901	2245	40.1%
17. Archibald Ave/Riverside Dr	1326	1610	2936	334	396	730	3666	19.9%
19. Haven Ave/Riverside Dr	1428	2248	3676	150	173	323	3999	8.1%
20. Haven Ave/Riverside Dr	576	690	1266	66	72	138	1404	9.8%
21. Haven Ave/Riverside Dr	798	975	1773	152	202	354	2127	16.6%
A1. Carpenter Ave/E. Riverside Dr	332	510	842	371	468	839	1681	49.9%
B1. Hellman Ave/E. Riverside Dr	332	510	842	525	563	1088	1930	56.4%

¹ Armstrong Ranch Project Volumes are Phase 3 Project Build-out with Elementary School Use

SECTION V FINDINGS AND RECOMMENDATIONS

A. ROADWAY AND INTERSECTION INFRASTRUCTURE IMPLEMENTATION PLAN

This analysis has confirmed that LOS D or better will be maintained throughout the project study area roadway segments for all project phases including build-out based on the infrastructure improvements identified in the Armstrong Ranch Specific Plan. Roadway improvements will be implemented to construct half-sections of ultimate roadway configurations along the Project frontage and full-width roadway improvements will be constructed for Hellman Avenue and other on-site collector and local roadways. Figures 41A and 41B provide the Specific Plan cross sections for the proposed project arterial, collector and local roadways.

The Specific Plan identifies that the intersections of Riverside Avenue/Hellman Avenue and Chino Avenue/Hellman Avenue are to be signalized with project development. Based on peak hour traffic signal warrant analysis only the Riverside Drive/Hellman Avenue intersection satisfied signal warrants. However, this analysis also identifies that the Carpenter Avenue and Riverside Drive intersection satisfies warrants for signalization. This analysis recommends that both of these intersections be signalized as part of Phase 2 project development. No other project access or on-site intersections require signalization and will provide desirable LOS with stop-control in both peak hours.

A.1 Off-site Intersection and Roadway Analysis and Mitigation Recommendations

This analysis confirms that all roadway segments included in this analysis will meet LOS D performance criteria for future with project and cumulative project conditions. Six (6) off-site study area intersections are predicted to not meet City LOS E criteria with future cumulative project and completion of Armstrong Ranch development. Specific recommended mitigation measures (Table 11) including an initial opinion of construction cost have been identified for each deficient intersection to restore acceptable LOS. An Armstrong Ranch Project fair share contribution (Table 12) has

July 2016

also been identified for each of these intersection mitigations. The identified mitigation measures have been considered in terms of feasibility and cost efficiency, however, the costs identified should be considered order of magnitude only and have not been developed based on a detailed engineering analysis. A preliminary feasibility analysis of proposed project mitigation measures is provided on Table 13.

A.2 SR-60 Freeway Mainline Analysis

This study analyzed existing freeway traffic volumes and future forecasts of cumulative project and worst-case Project build-out traffic volumes and identified that for existing and future conditions the SR-60 Freeway from east of Haven Avenue to West of Grove Avenue is operating and will continue to operate at desirable LOS D and C. No mitigation to State facilities is required by Project implementation.

MAJOR ARTERIAL:

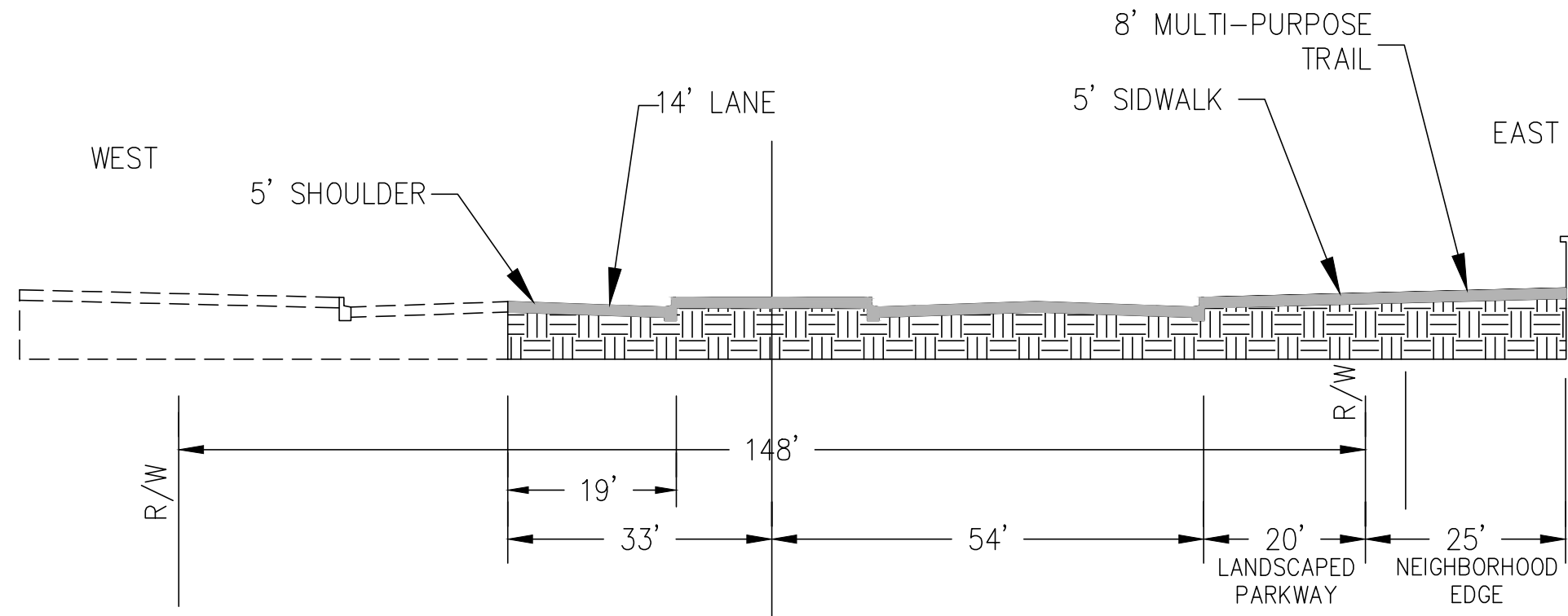

**VINEYARD AVENUE
N.T.S**

MINOR ARTERIAL:

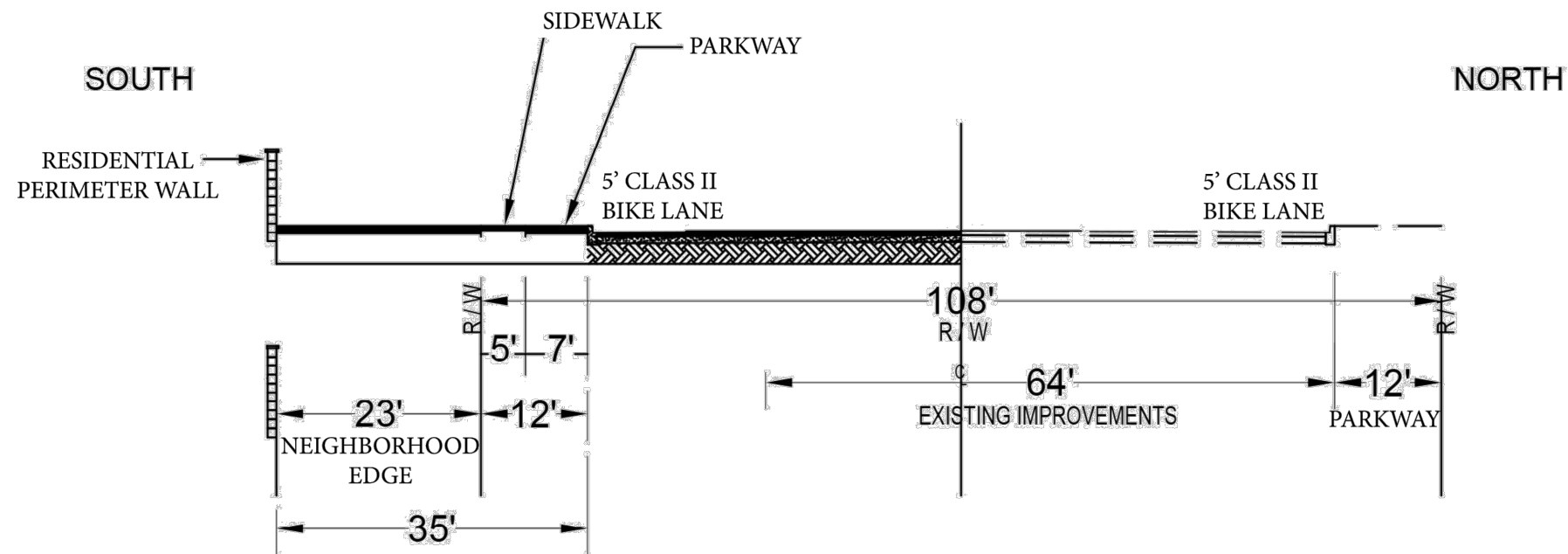

**RIVERSIDE DRIVE
N.T.S**

PREPARED BY:



**ARMSTRONG RANCH
TRAFFIC IMPACT STUDY
ONTARIO, CA**

**FIGURE 41A
PROPOSED ARTERIAL ROADWAY SECTIONS**

4-LANE COLLECTOR:

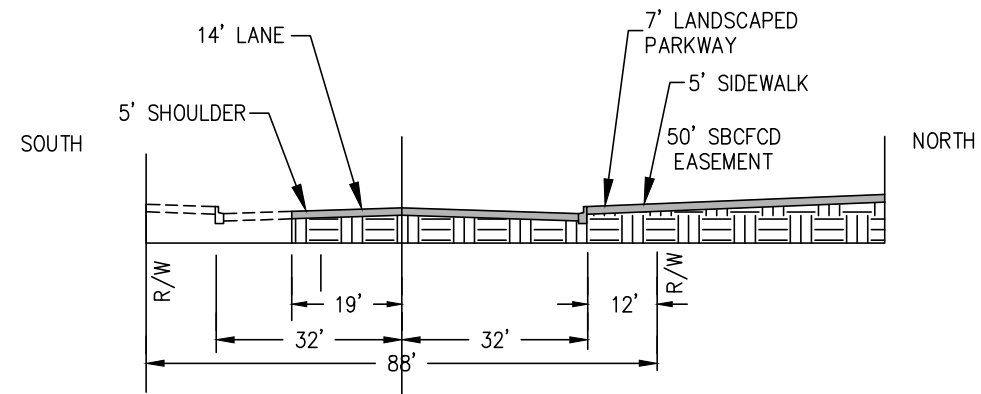

CHINO AVENUE
N.T.S.

LOCAL STREET:

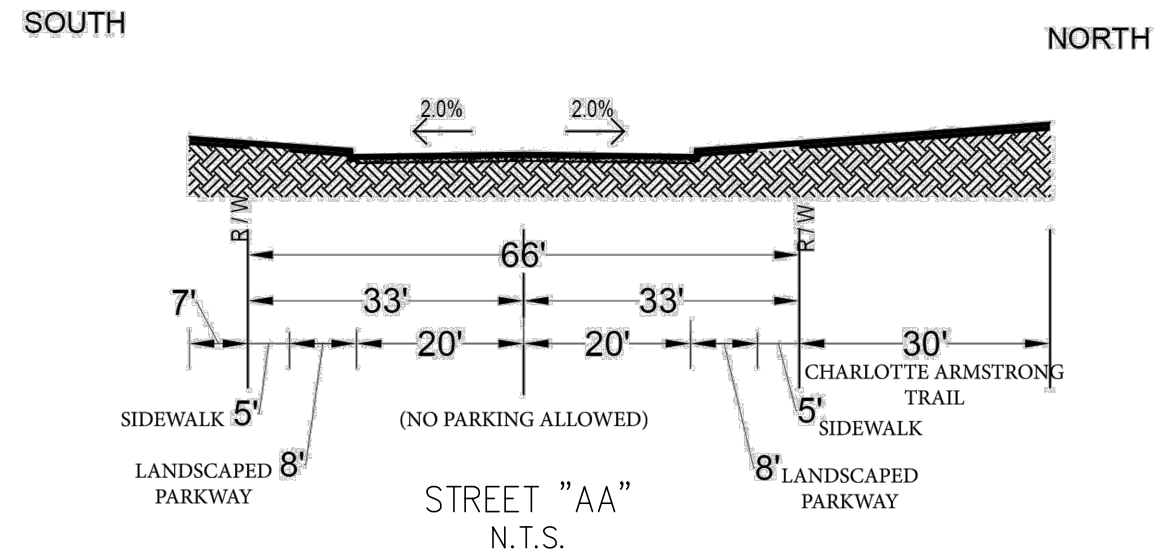

STREET "AA"
N.T.S.

2-LANE COLLECTOR:

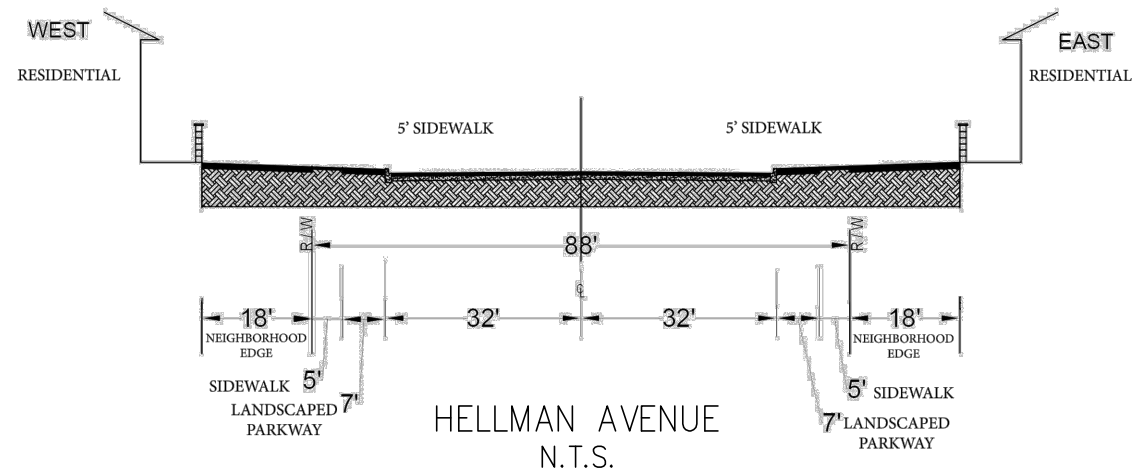

HELLMAN AVENUE
N.T.S.

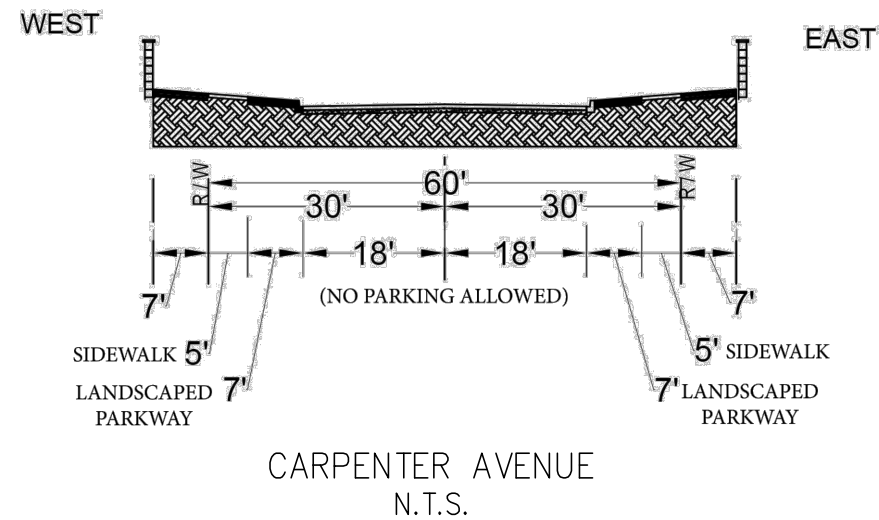

CARPENTER AVENUE
N.T.S.

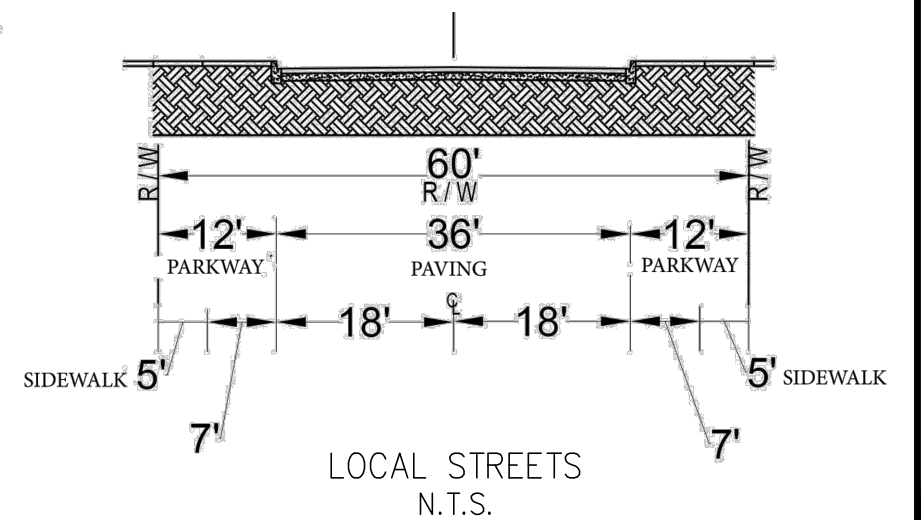

LOCAL STREETS
N.T.S.

PREPARED BY:



ARMSTRONG RANCH
TRAFFIC IMPACT STUDY
ONTARIO, CA

FIGURE 41B
PROPOSED COLLECTOR AND
LOCAL ROADWAY SECTIONS



TABLE 13
Preliminary Feasibility Analysis of Proposed Project Mitigation Measures

Intersection	Mitigation	Preliminary Opinion of Cost	Right-of-Way Required?	Utility Impacts/ Comments	Other Significant Impacts/Constraints	Overall Feasibility	Description of Improvements
13. Euclid Ave/Riverside Dr	Add 3rd NB & SB through lanes	\$250,000	No	Ex. OH power lines/ utilities along S/S of Riverside Drive to remain in place	None Noted	High	Exist. construction project at time of study widening NEC. Widen SEC within exst. R/W to provide 3rd NB lane through intersection and maintain a NB Rt-turn lane. Construct C&G on SB egress leg (SWC) to join existing and restripe to provide 3rd SB lane through intersection; modify traffic signal.
16. Vineyard Ave/Riverside Dr	Add 2nd SB Left-turn Lane	\$5,000	No	Ex. OH power lines and utilities along north, south and east side of intersection. OH lines along project frontage will be relocated or underground	None Restriping Only	High	Proposed mitigation requires restriping and minor traffic signal modification within existing R/W on the northerly approach. Project implementation will require roadway and traffic signal improvements on the south side of the intersection and are not included as part of this mitigation.
17. Archibald Ave/Riverside Dr	Provide dual left-turn lanes on all approaches	\$550,000	No	Ex. OH power lines/ utilities along E/S of Archibald & S/S Riverside to remain	None Noted	High	Proposed mitigation requires reconstruction of southerly approach within existing R/W and restriping intersection and modifying traffic signal to provide dual left-turn lanes on
19. Haven Ave/Riverside Dr	SB: 1-Rt, 1-thru, 2-Lts NB: 1-Lt, 1-thru; 1-thru/Rt EB: Add 1-thru and 1-Lt WB: Add Rt-turn lane	\$800,000	Unknown - R/W acquisition not Included in cost	There are existing power lines along the S/S of Riverside Dr that may require relocation or undergrounding	There is an existing triple-box culvert crossing Haven on the N/S of the intersection. There are also ex. private prop. Imps. near the roadway on the southerly leg.	Medium	This mitigation requires reconstructing and/or removing the raised median on the northery approach and widening the northbound, eastbound, and westbound approaches, and major modification of the existing traffic signal. R/W acquisition and private property improvements may be required for implementation and these costs have not been included.
20. Grove Ave/Chino Ave	Install Traffic Signal	\$400,000	No	Ex. OH power lines/ utilities along E/S of Grove & S/S Chino to remain in place	None Noted	High	Construction of traffic signal and curb returns/landings with ADA-compliant ramps
21. Vineyard Ave/Chino Ave	Install Traffic Signal	\$400,000	No	Ex. OH power lines/ utilities along S/S of Chino to remain	None Noted	High	Construction of traffic signal and curb returns/landings with ADA-compliant ramps
A1. Carpenter Ave/Riverside Dr	Install Traffic Signal	\$400,000	No	Ex. OH power lines and utilities along north and south side of Riverside Dr.; OH lines along project frontage will be relocated or underground	Carpenter Ave approach should align with Whispering Lakes Lane	High	Construction of traffic signal
B1. Hellman Ave/Riverside Dr	Install Traffic Signal	\$400,000	No	Ex. OH power lines and utilities along north and south side of Riverside Dr.; OH lines along project frontage will be relocated or underground	None Noted	High	Construction of traffic signal