

# Section 4

# Infrastructure and Public Facilities

To accommodate the development envisioned in the Ontario Festival Specific Plan, infrastructure and public facility improvements will be constructed to tie into existing utility facilities.

“Land Use Summary”, Tables 4.1 and 4.2 offer a breakdown of potential land uses.

**Table 4.1**

Land Use Summary

Land Use	Acres	% Of Total Acres
Planned Residential (PR)	26.4 AC±	72%
Non-Participating PR	0.96 AC±	3%
Garden Commercial II	3.6 AC±	10%
Existing Commercial	5.7 AC±	15%
Total	36.7 AC±	100%

**Table 4.2**

Land Use Summary with Planned Residential Overlay

Land Use	Acres	% Of Total Acres
Planned Residential (PR)	27.1 AC±	74%
Non-Participating PR	3.9 AC±	11%
Existing Commercial	5.7 AC±	15%
Total	36.7 AC±	100%

## 4.1 Water Facilities

The City of Ontario water main is a 12-inch line located in Inland Empire Boulevard. The on-site water system for the Brookfield Residential Development will be a public system. A 12-inch recycled water line also exists in Inland Empire Boulevard. See Exhibit 4-1, “Existing Domestic and Recycled Water Utility”.

### 4.2 Sewer Facilities

The existing 30" sewer line sewer main in Inland Empire Boulevard and the existing 24" sewer main in Turner Avenue are owned by the Inland Empire Utilities Agency (IEUA). Ontario Regional Connection, number 0-61, located in Inland Empire Boulevard, approximately 1,050 feet east of Archibald Avenue, has previously been approved and constructed to accept sewage flows based on the project demand for the previously approved site plan. The work has not been completed. See Exhibit 4-2, "Existing Sewer Utility". There is also a 30" industrial waste line belonging to the Inland Empire Utilities Agency (IEUA) in the south side of Inland Empire Boulevard. See Exhibit 4-3, "Existing Industrial Waste Utility".

### 4.3 Storm Drain System

There are no permanent storm drain lines or facilities adjacent to the proposed project. There is an existing 42" storm drain, which terminates approximately 130 feet east of the Archibald Avenue and Inland Empire Boulevard intersection. Approximately 140 feet of storm drain was as-built per previous approved plans. The existing storm drain system extends westerly in Inland Empire Boulevard and outlets into an open ditch on the north side of the I-10 Freeway. The open ditch drains southerly parallel to North Archibald Avenue and connects to a system that takes it under the freeway to another series of open ditches. The water is then conveyed to a system crossing Airport Drive to a RCB that runs westerly within the Airport, ultimately connecting to the Cucamonga Creek Channel.

To drain the project site, a proposed 42" storm drain line will be constructed from the site westerly along Inland Empire Boulevard and connected to the existing 42" storm drain. Exhibit 4-4, "Existing and Proposed Storm Drain Utility" shows the location of the existing and proposed storm drains. Since the downstream portion of the storm drain system is not at its ultimate completion, the project must detain storm water runoff on site such that post project development peak Q100 runoff is 80% of the existing peak pre-development runoff. A detention basin or basins will be constructed on site to detain the peak flow. The basin or basins would be maintained by the Property Owners Association. All basins constructed will be temporary until the time in which ultimate downstream drainage improvements are constructed. Storm flows from the project site tributary to Inland Empire Boulevard shall not extend outside of the parking lane. The parking lane is described as the northerly 8' of the street measured from the northerly curb.

The grading and drainage of the Ontario Festival Specific Plan shall be designed to retain, infiltrate and/or treat surface runoff to achieve NPDES compliance.

Exhibit 4-5, "Conceptual NPDES Compliance Concept", portrays a possible drainage routing and design concept to accomplish NPDES mitigation. It is based on the "Conceptual Site Plan" as shown on Exhibit 3-4.

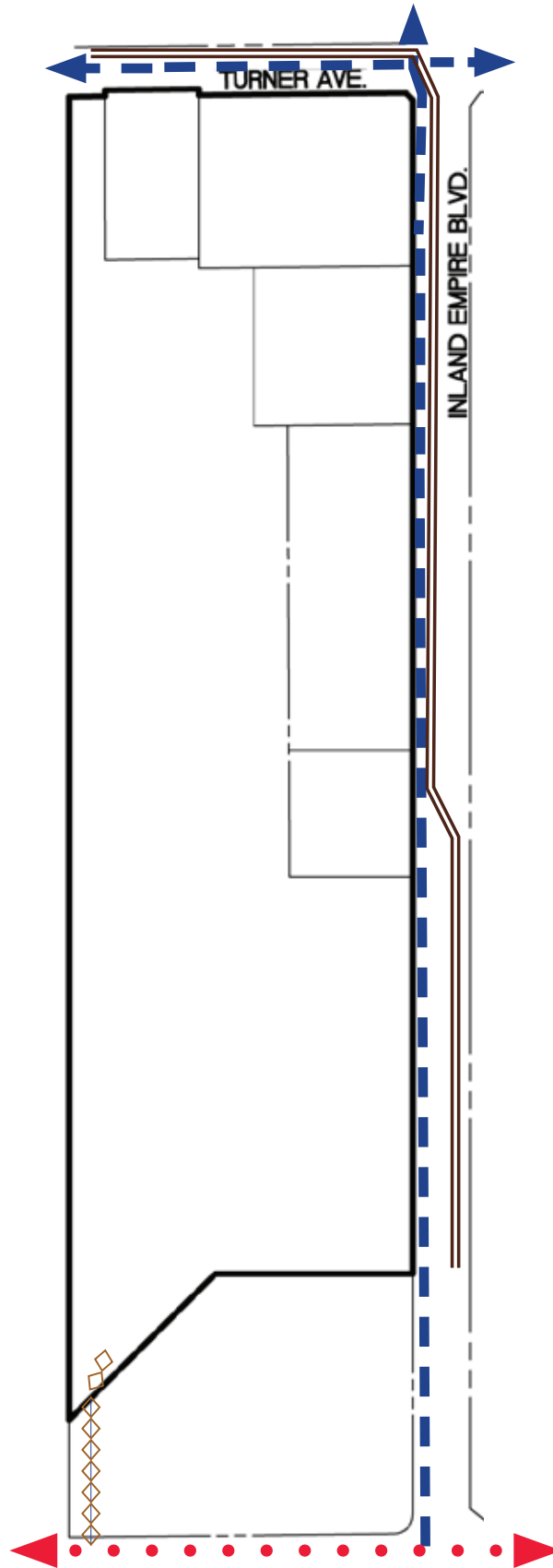

**LEGEND**

- 12-INCH DOMESTIC WATER
- 10-INCH DOMESTIC WATER
- 8-INCH DOMESTIC WATER
- 12-INCH RECYCLED WATER

Existing Domestic and Recycled Water Utility

Exhibit 4-1

# ONTARIO FESTIVAL

Specific Plan

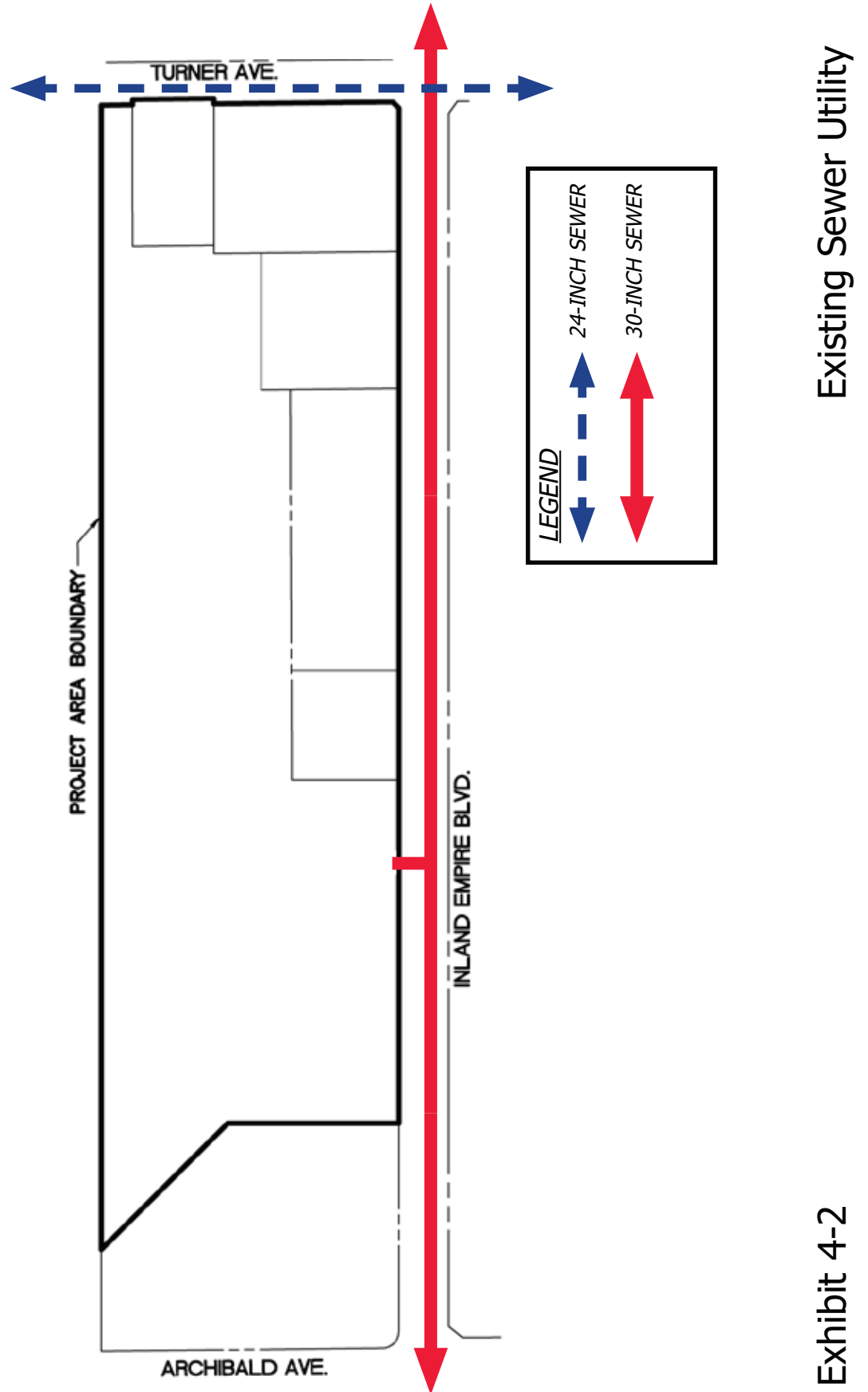

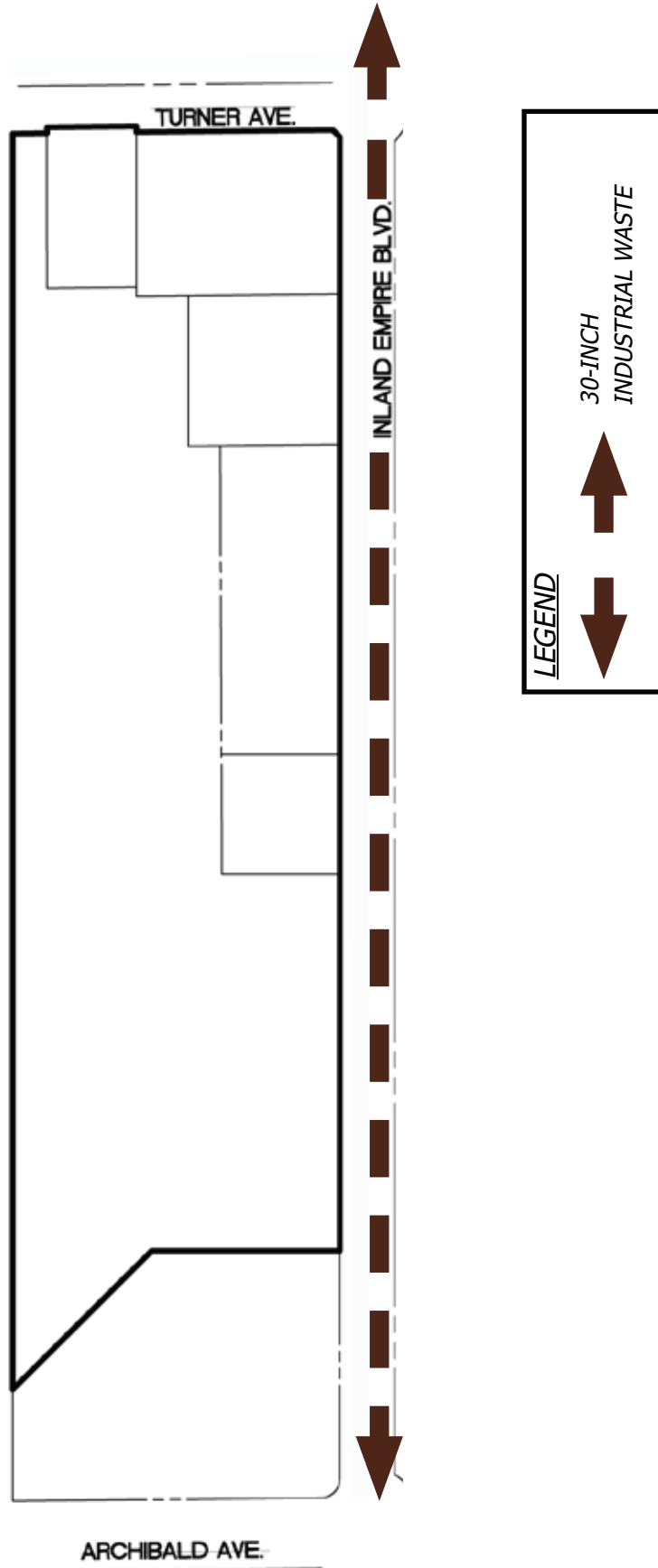

Existing Industrial Waste Utility

Exhibit 4-3

# ONTARIO FESTIVAL

Specific Plan

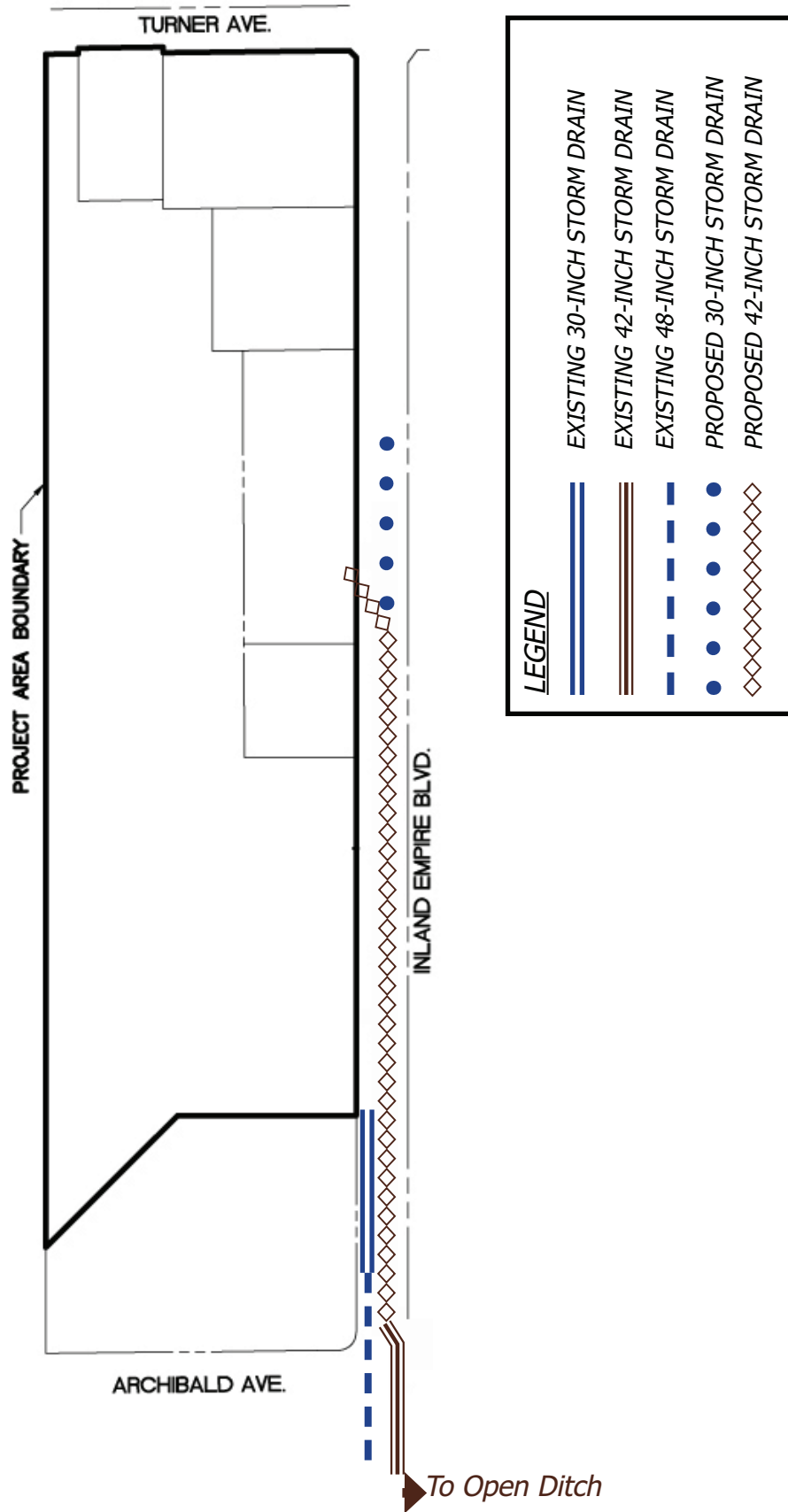

Existing & Proposed Storm Drain Utility

Exhibit 4-4

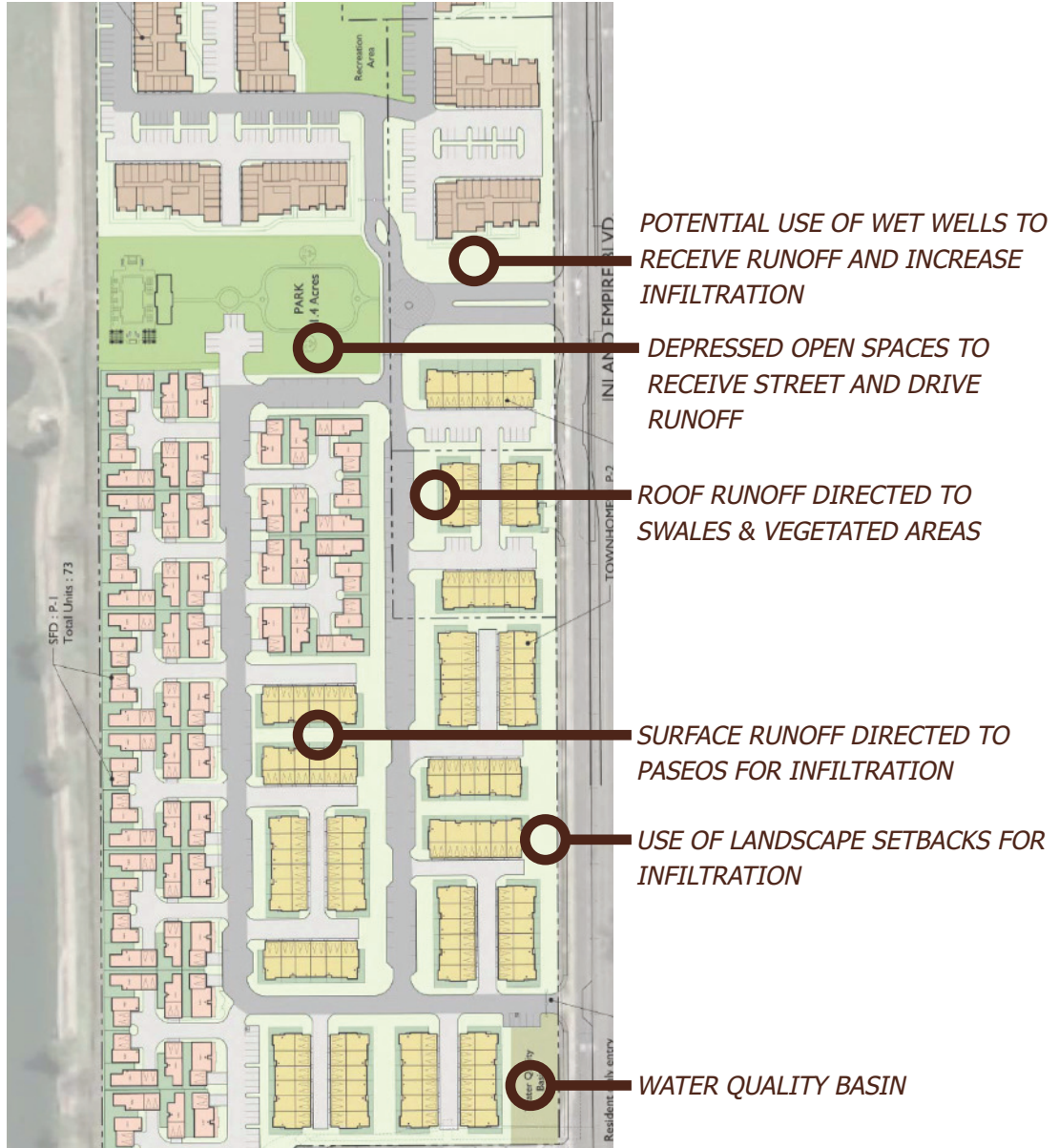

Site Plan Concept Shown for Illustrative Purposes Only

## Conceptual NPDES Compliance Concept

## Exhibit 4-5

## **4.4 Fire Department Services**

The City of Ontario provides fire protection for the project. The nearest fire station (3429 E. Shelby St.) is approximately 1 mile away from the proposed project.

## **4.5 Police Department Services**

The City of Ontario provides police protection for the project. The police station (200 N. Cherry Avenue) is approximately 4.4 miles away from the proposed project. Response time varies based on location of police units and type of calls according to Police Department statements.

## **4.6 Solid Waste**

It is anticipated that, pursuant to the Ontario Festival Specific Plan, solid waste collection and disposal will be accomplished by city crews through the City of Ontario Public Works Agency.

Ontario Festival supports any City-sponsored recycle program and diversion of special wastes such as tires, construction material, etc.

## **4.7 Electricity and Natural Gas**

Southern California Edison (SCE) provides electricity to the Project Site. SCE has overhead facilities in the area servicing commercial areas to the south of Inland Empire Boulevard. All existing overhead utility lines along Inland Empire Boulevard and Turner Avenue will be relocated underground concurrent with improvements to the frontages of Inland Empire Boulevard and Turner Avenue. The development of the Ontario Festival Specific Plan area will increase electrical power requirements, and SCE will develop the required distribution system.

The Southern California Gas Company has natural gas service within the Project area. There are existing gas lines located in Archibald Avenue.

## **4.8 Communication Systems**

Verizon provides telephone service within the Project area. Currently, telephone service is provided to commercial areas to the south of Inland Empire Boulevard.



## 4.9 Vehicular Circulation

The Project Site will be served by a system of existing and proposed roadways. Existing roadways include Inland Empire Boulevard (Divided Arterial Street) serving as the southerly boundary of the Project Site, Turner Avenue (Collector Street) serving as the easterly boundary of the Project Site and Archibald Avenue serving as the westerly boundary of the site. Inland Empire Boulevard with the NP parcels as GC2 will provide four (4) right in/out access points. The NP parcels will not have right in/out access points when developed as Planned Residential as they will take access internally. One (1) full vehicular entry/exit point of access on Inland Empire Blvd. will serve as the major entry to the Planned Residential areas of the project. Turner Avenue will have a full vehicular entry/exit point of access, which will serve as minor entry. Fully improved Archibald Avenue provides access to the existing commercial site at the northeast corner of Inland Empire Boulevard and Archibald Avenue. These streets will provide access to and from the Project Site. Additionally, offsite regional access to and from I-10 will be from Archibald Avenue to the west and Haven Avenue to the east.

On-site circulation within the Ontario Festival Specific Plan will be provided through a system of local private streets to be constructed internal to the project. All interior neighborhoods will have a minimum of two (2) points of access and two right in/out only. Inland Empire Boulevard will connect east/west traffic and Turner Avenue will connect north/south traffic flow.

A Traffic Impact Report, performed in January 2012, was prepared by Linscott, Law & Greenspan, Engineers (LLG), for the project. A traffic generation comparison was conducted between the previously approved SP and the proposed development.

Circulation improvements proposed as part of the Ontario Festival Specific Plan are described and illustrated on Exhibit 4-6, "Circulation Plan, Entry and Roadway Classifications".

### *Divided Arterial—Inland Empire Boulevard*

The Divided Arterial Street, Inland Empire Boulevard, is designed to carry regionally oriented traffic safely and efficiently between various points along the I-10 corridor, and acts as a frontage road from the freeway to various uses along the corridor.

In conjunction with development of the project Inland Empire Boulevard will be improved to a ½ width street improvement of 39 feet of paving along the project boundary. A 14 foot wide landscaped median will be constructed from Turner Avenue to the westerly tract boundary. The median will continue westerly, after the intersection of Inland Empire Boulevard and intersecting drive approaches, as a 4 foot wide median to Archibald Avenue. A median opening will be provided at the main project entry. A 12 foot parkway will be provided and will serve as a landscape buffer from the development. There is a Class 3 2 Bike Route proposed in the street right-of-way, as required by the City of Ontario General Plan. A major full turn signalized entry into the Project Site is planned at the major entry intersection. A right turn in-out minor entry is planned for the Planned Residential land use area fronting on Inland Empire Boulevard. Likewise, an existing drive from Inland Empire Boulevard for the existing Garden Commercial I land use area will be signalized. A bus turnout will be provided on the north and south side of Inland Empire Boulevard between Archibald and Turner Avenue and a bus shelter shall be

provided on the north side of Inland Empire Boulevard between Archibald and Turner Avenue. The bus turnouts shall be installed to City standards. The bus shelter shall be designed to complement the architectural style of the proposed development. A possible transit stop location is shown on Exhibit 4-6, “Circulation Plan Entry and Roadway Classifications”. Exhibit 4-6a, “Inland Empire Boulevard - Street Section”, illustrates the proposed improved Inland Empire Boulevard.

### *Collector—Turner Avenue*

The Collector Street, Turner Avenue, is an 88-foot wide right-of-way, with ½ street improvements along the east boundary of the Project Site. It provides north/south access for the project, a full vehicular entry/exit into the Garden Commercial I area and a full vehicular entry/exit for the Planned Residential area. The Ontario Festival project will improve the west half of the street with 32 feet of paving and a 12 foot landscaped parkway.

Exhibit 4-6b, “Turner Avenue Street Section” illustrates the Turner Avenue proposed improvements.

### *Primary Entry –Private Street, from Inland Empire Boulevard*

The major entry is located at an approximate mid-point along the Inland Empire street frontage. This heavily landscaped entry will consist of an 88 foot right-of-way, divided by a ten foot (10’) raised landscaped median. Seven foot (7’) landscaped parkways are proposed on each side of the entry street. Five foot (5’) sidewalks will be contained within the parkways framed on the outside edges by an additional seven foot (7’) landscaped parkway/buffer. The pavement width in each direction will be 20 feet with rolled curb. As the street enters the residential portion of the project, it may circulate to an access controlled gate. Primary thematic entry monumentation will be established at the intersection with Inland Empire Boulevard.

The main entry and streets are designed to easily accommodate school bus and fire truck access and circulation.





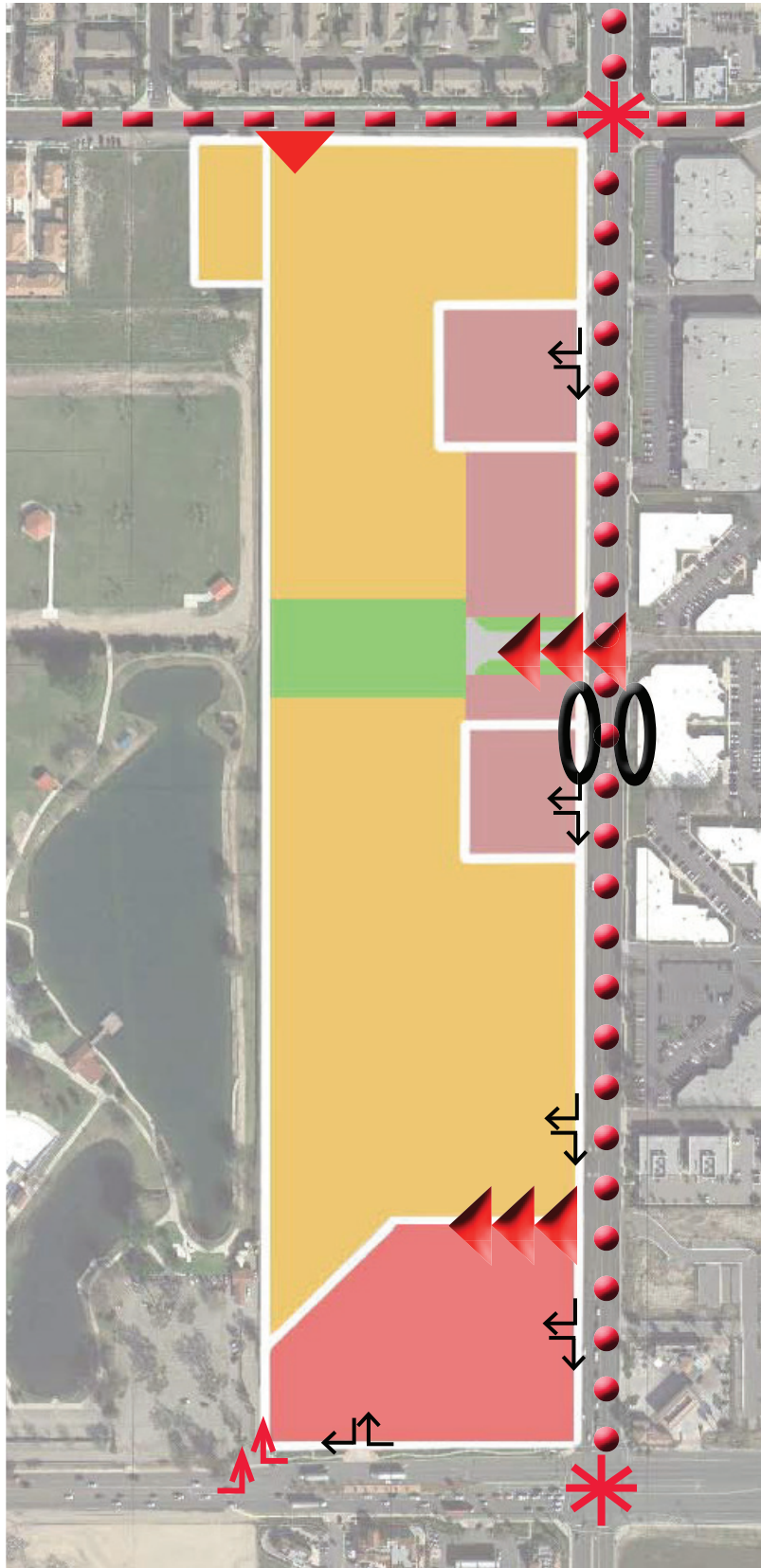

The Primary Entry Street sections are shown on Exhibit 4-6c and 4-6h, “Primary Entry Street Section from Inland Empire Boulevard”.

### *Private Residential Streets*

Interior circulation will be provided by residential streets consisting of a 36 foot wide right-of-way. The paving width will consist of 36 feet with 10 foot driving lanes and eight foot parking lanes with rolled curbing in both directions. An eight foot landscaped parkway will be installed on at least one side of the street containing a four foot wide sidewalk in which case a minimum 5 foot landscape buffer would be required opposite.

The street improvements for the Private Residential Streets are illustrated in Exhibit 4-6d, “Typical Private Residential Street Section”.



-  Proposed Signalized Access
-  Existing Signal
-  Right In/Right Out Access (for NP parcels, only when developed as GC II)
-  Right In/Left In Access
-  Collector
-  Divided Arterial
-  Bus Turnout (Conceptual location)
-  Full Access

Circulation Plan, Entry & Roadway Classification

Exhibit 4-6

# ONTARIO FESTIVAL

## Specific Plan

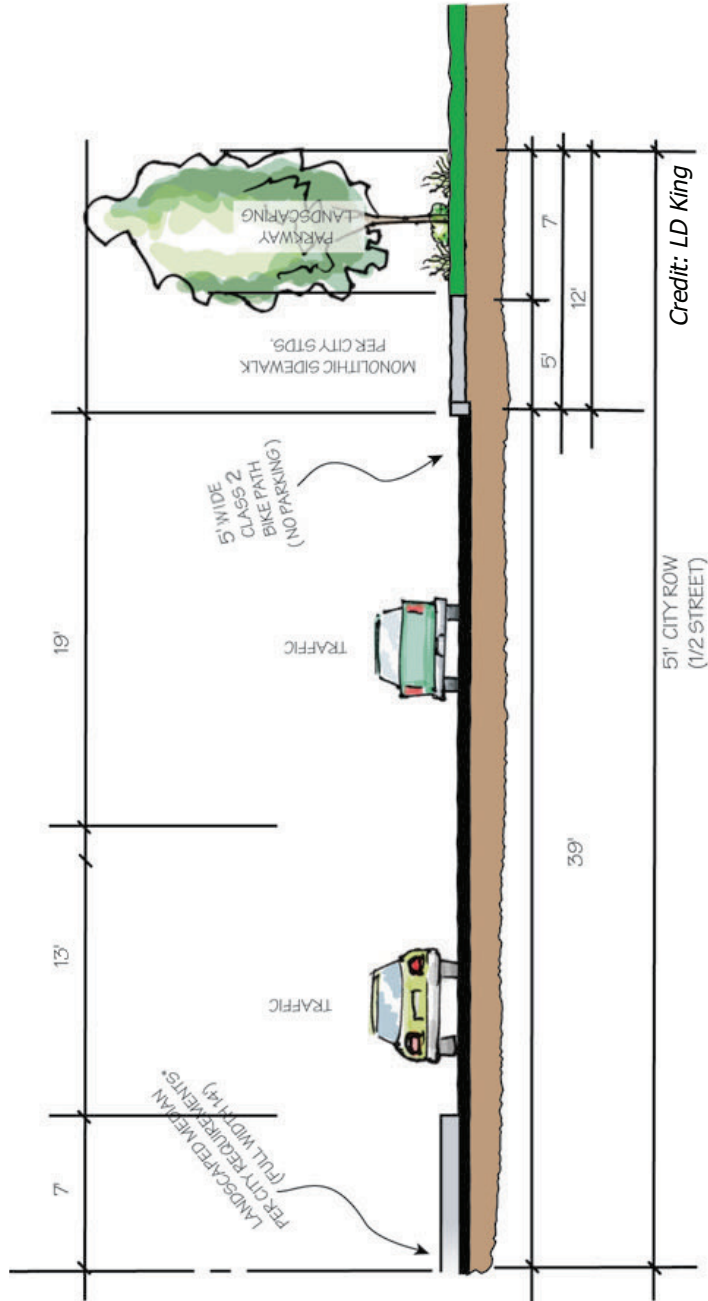

Inland Empire Blvd.

Exhibit 4-6a

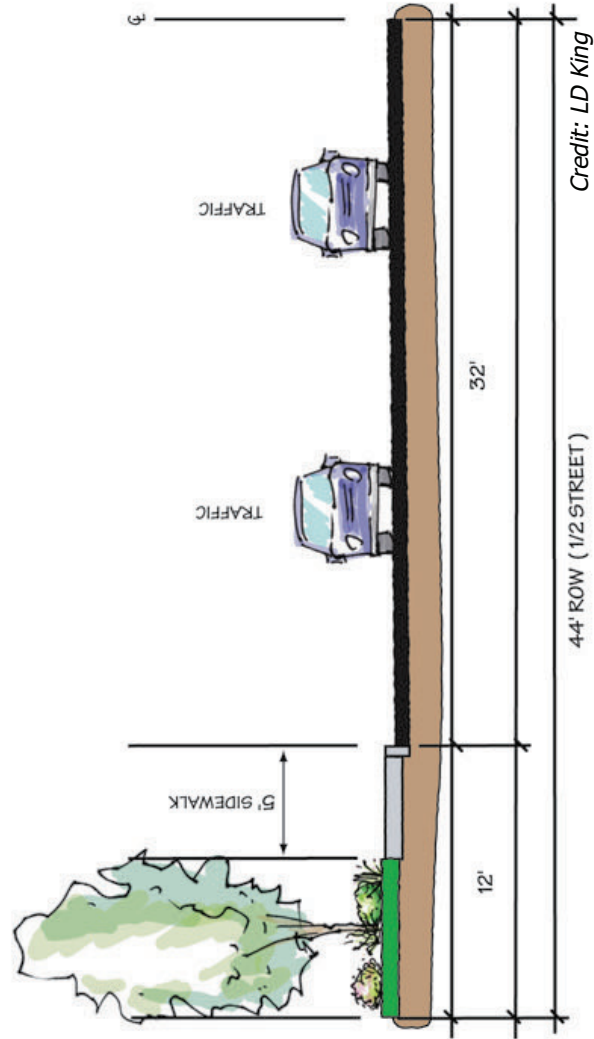

## Turner Ave. Section

## Exhibit 4-6b

# ONTARIO FESTIVAL

## Specific Plan

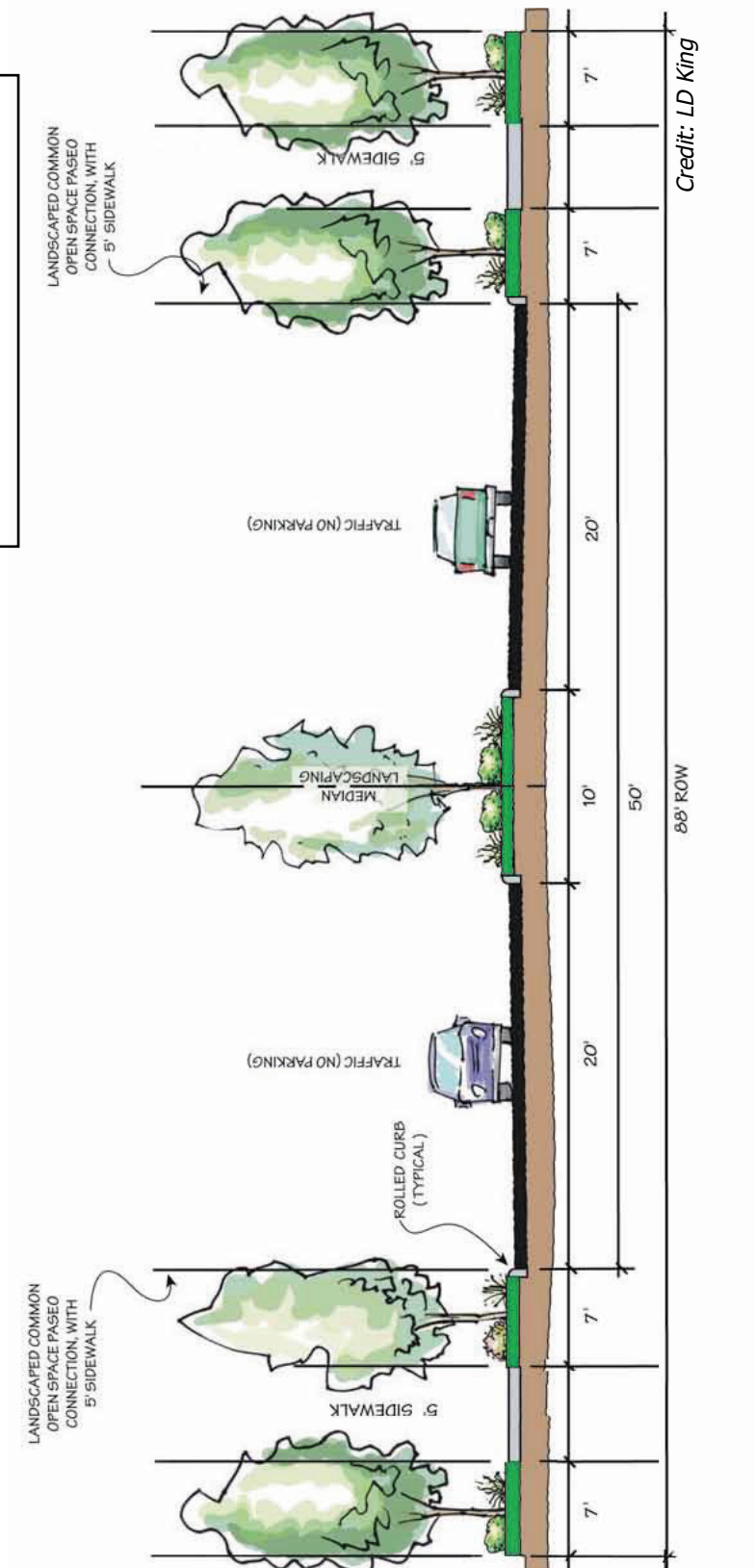
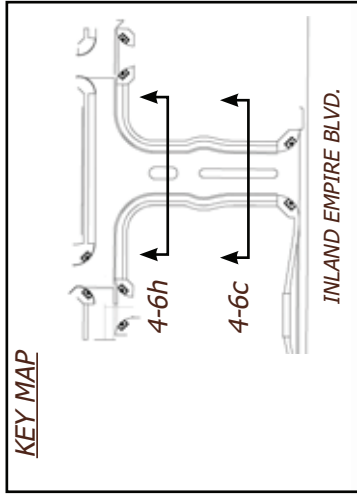

Primary Entry from Inland Empire Blvd.

Exhibit 4-6c

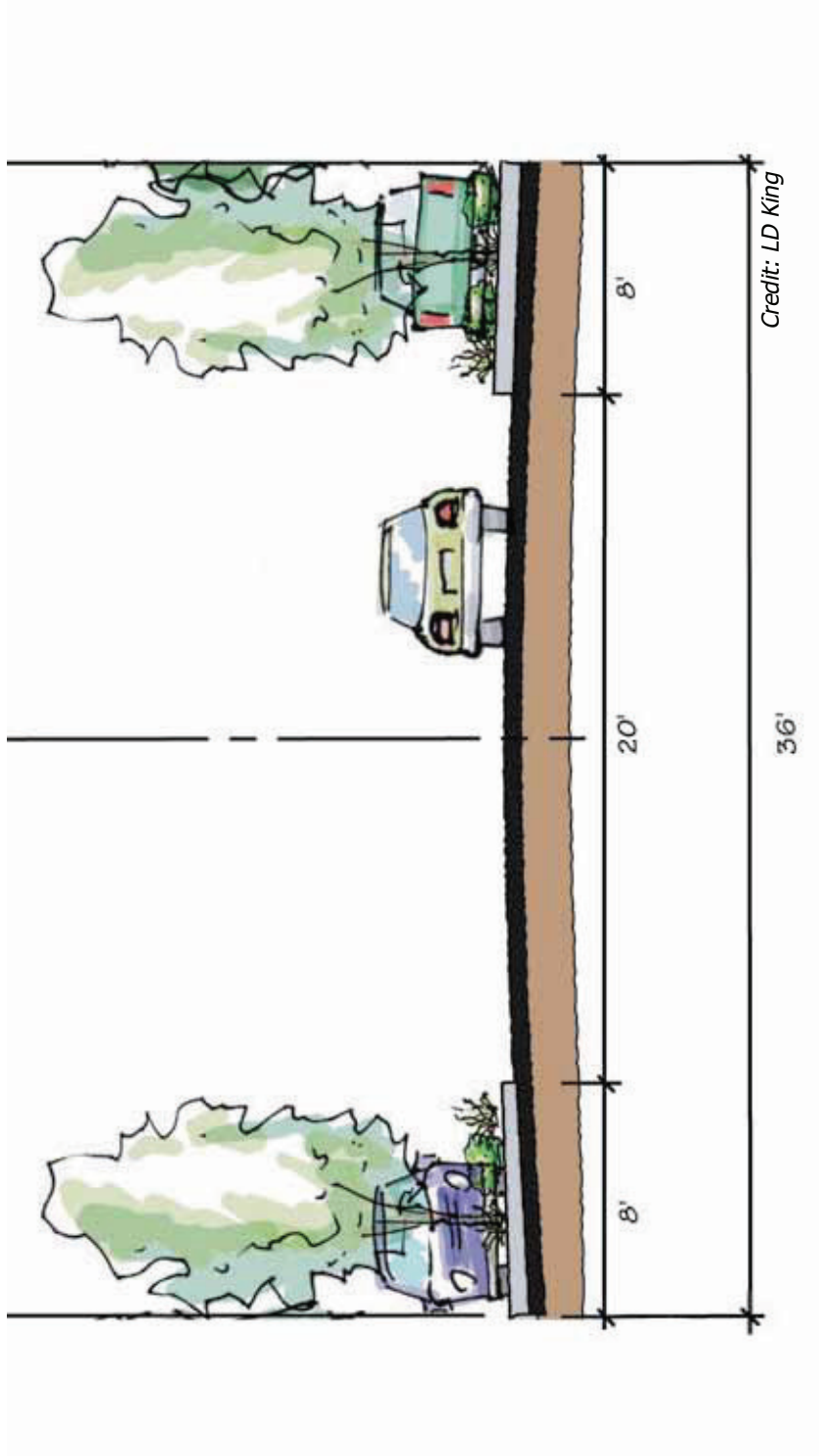

Typical Private Residential Street-Type 1

Exhibit 4-6d

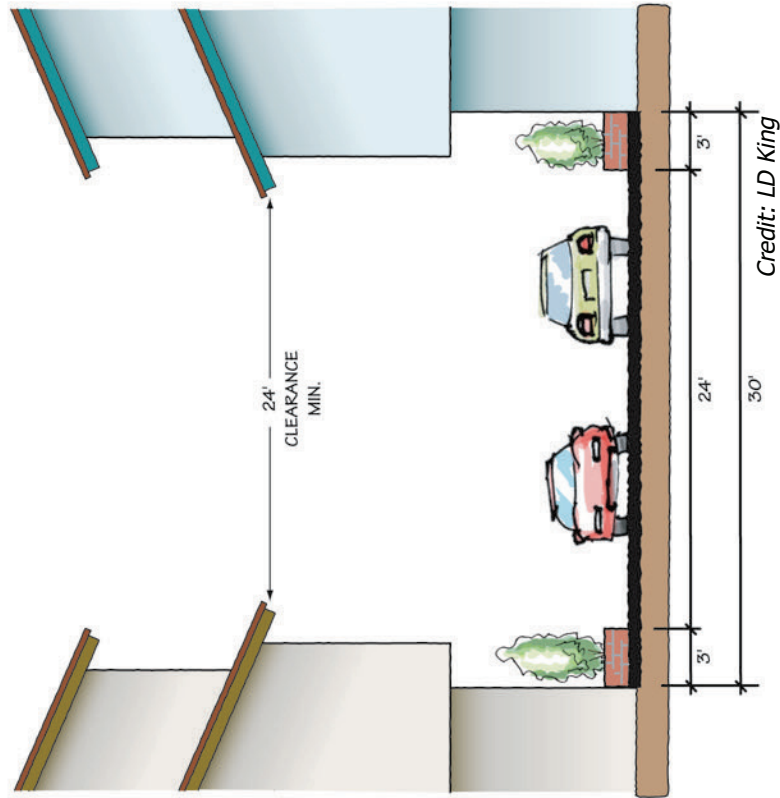

NOTE: Alleys may have a 20' clear drive aisle with 5' setbacks to garage or 24' clear paveway with 3' setbacks to garage to meet the minimum 30' garage to garage setbacks. In either case, a 24' eave to eave separation must be maintained.



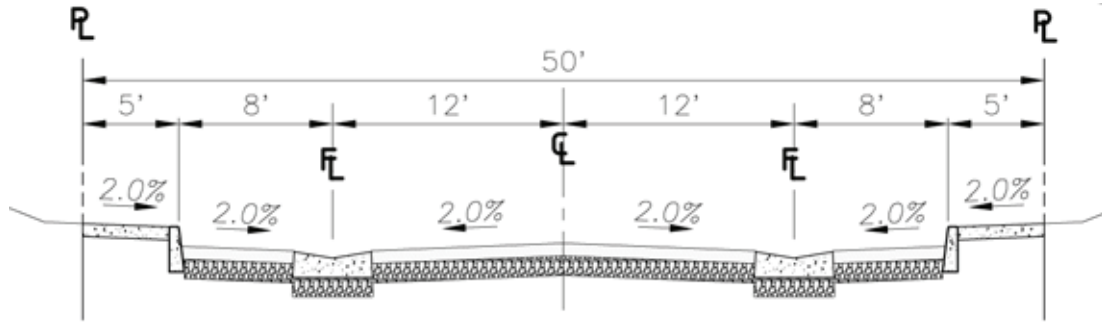

Type 2 Private Residential Street

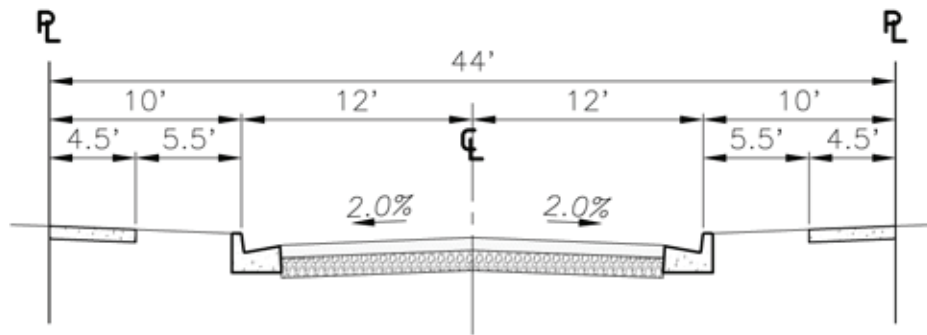

Type 3 Private Residential Street

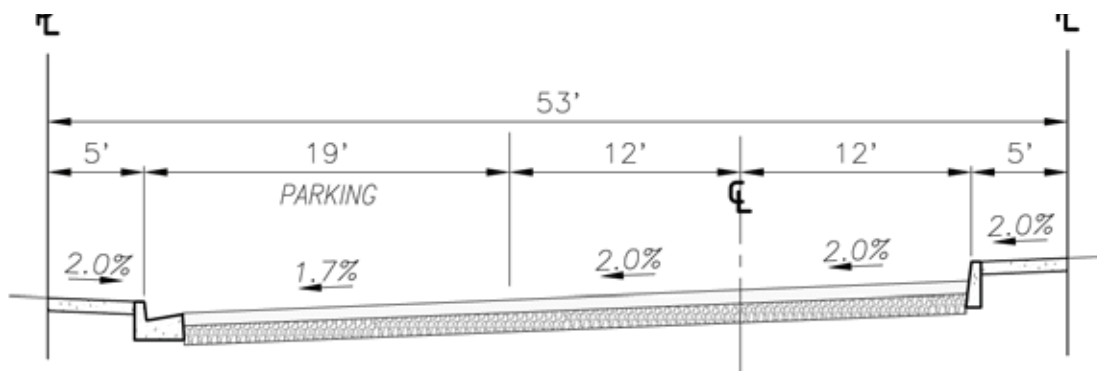

Type 4 Private Residential Street

Typical Private Residential Street - Types 2, 3 & 4

Exhibit 4-6f

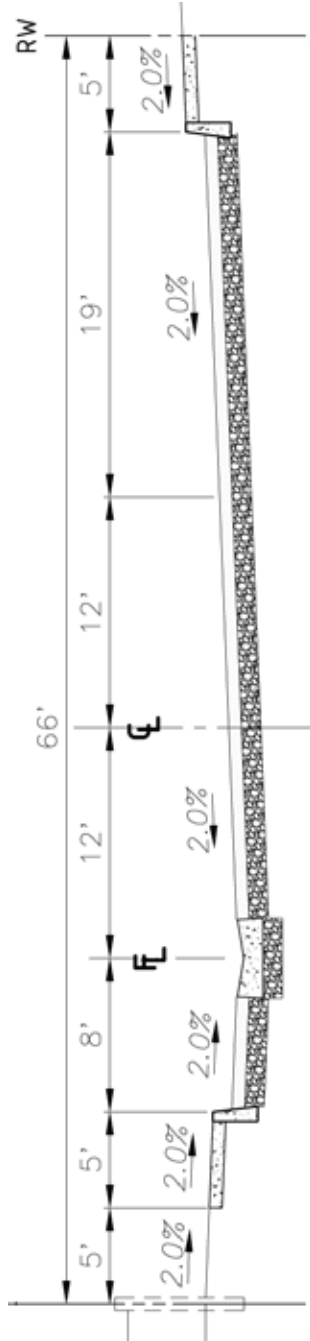

Type 5 Private Residential Street

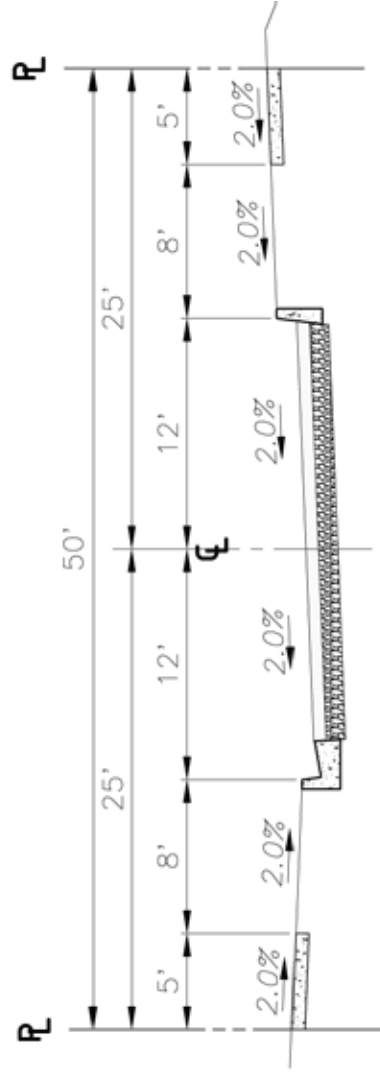

Type 6 Private Residential Street

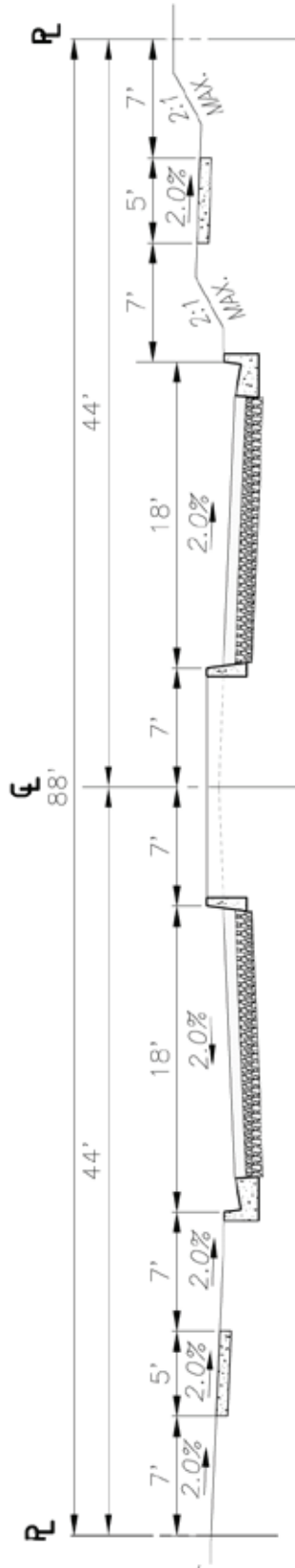
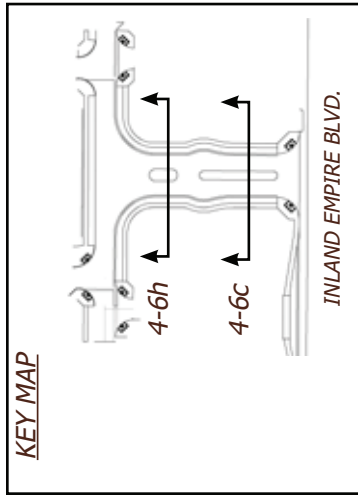

Primary Entry from Inland Empire Blvd.

Exhibit 4-6h

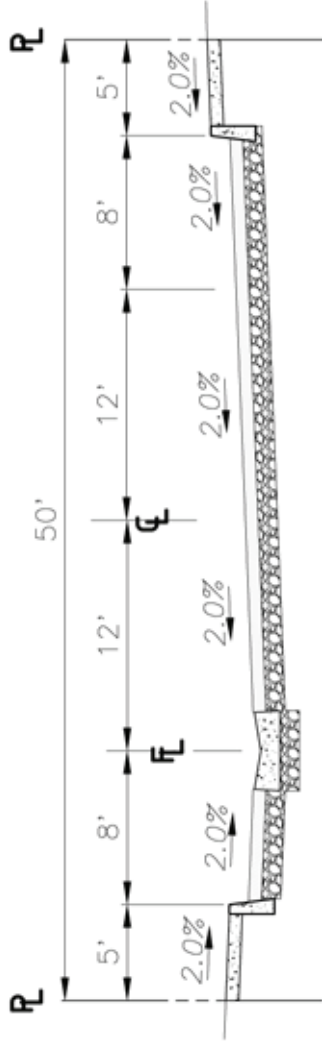

Type 7 Private Residential Street

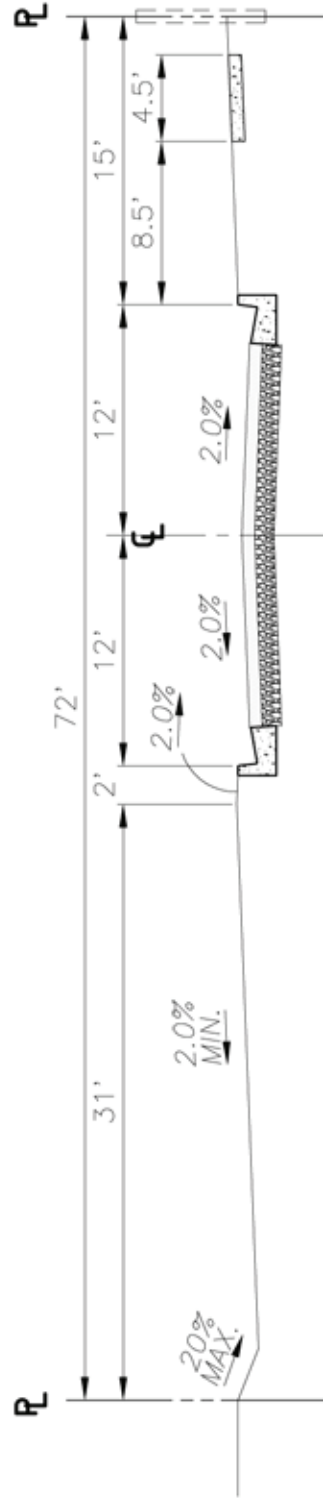

Type 8 Private Residential Street

## *Short Access Alleys*

Short Access alleys will provide access for the residential areas not fronting directly onto the Private Interior Streets. The street improvements will consist of 24 feet of paving with rolled curbs. No parking will be allowed in the alleyways. A 3 foot wide landscape strip will be installed on both sides. An alternative paveway condition consists of 20 feet of paving with a 5 foot wide landscape strip/setback to the garage. Exhibit 4-6e, “Typical Alley Section” depicts the alleyway section.

## *Commercial Site Access*

There is an existing driveway located adjacent to the western boundary of the Planned Residential land use area that provides right-in and right-out access to the rear of the commercial site. At the north end of this segment the driveway splits into a circulation drive and a parking area/service drive. As part of the residential development, the residential developer will provide an access easement of 4 feet to this drive at which point the developer will construct a wall to provide a degree of privacy and noise protection from the drive. To the west of this access point on Inland Empire Blvd. there is a right-in/right-out driveway accessing the main parking field as shown on Exhibit 4-6, “Circulation Plan, Entry & Roadway Classification”. A 5-foot deep landscape buffer shall be provided immediately adjacent to the existing one-way drive aisle located on the east side of the Garden Commercial I property. A 6-foot high boundary wall shall separate the Garden Commercial I and Planned Residential areas.

At the northwest corner of the project there is an existing one-way access lane that splits and serves both as an entry to Guasti Park and as a circulation drive from the northwest portion of the commercial center to the rear parking area/service drive. The existing one-way access lane located adjacent to the east side of the Garden Commercial I boundary shall remain. The owner(s) of the Planned Residential land use area shall provide an access easement to the east of the existing commercial center, at the northwest corner of the Planned Residential land use area, to ensure that vehicular access will be maintained to the rear parking area and service drive of the commercial center, as depicted on Exhibit 4-6f.

To the south of the Guasti joint access point on Archibald there is a right-in/right-out driveway accessing the main parking field as shown on Exhibit 4-6, “Circulation Plan, Entry & Roadway Classification”.

## **4.10 Grading**

The existing ground has been mostly rough graded per previously approved grading plans, slopes towards the southwest, and will not require a large grading operation, nor will it result in noticeable cut or fill slope banks. The grading operation will generally consist of clearing and grubbing, demolition of existing structures, and moving surface soils to construct residential building pads and streets.

Grading plans for each tract in the Specific Plan area will be reviewed and approved by the City of Ontario Building, Planning, and Engineering Departments prior to the issuance of grading permits. All grading plans and activities will conform to the City grading ordinance and dust control and erosion control requirements.

# ONTARIO FESTIVAL

## Specific Plan



Exhibit 4-7

Existing Commercial Driveway and Improvements