

Appendix G1 2016 Geotechnical Report

Appendices

This page intentionally left blank.



CV COMMUNITIES

3121 Michleson Drive, Suite 150
Irvine, California 92612

April 14, 2015

Project Number 1-0152

Attention: Mr. Adam Smith

Subject: **PRELIMINARY GEOTECHNICAL INVESTIGATION**
Armstrong Ranch Specific Plan, DeBoer Parcels
City of Ontario, County of San Bernardino, California

References: See Appendix A

Mr. Smith

Presented herein is Alta California Geotechnical, Inc.'s (Alta) preliminary geotechnical investigation for the proposed Armstrong Ranch Specific Plan, located in the City of Ontario, California. The conclusions and recommendations presented in this report are based on Alta's recent subsurface investigation, laboratory testing, review of the Conceptual Site Grading Plan (Plate 1), and review of the referenced reports.

Alta's review of the data and site plan indicates that the proposed development is feasible, from a geotechnical standpoint, provided that the recommendations presented in this report are incorporated into the grading and improvement plans and implemented during site development. Included in this report are:

- Discussion of the site geotechnical conditions;
- Unsuitable soil removal and grading recommendations;
- Geotechnical site construction recommendations;
- Foundation design parameters.

If you have any questions or should you require any additional information, please contact the undersigned at (951) 509-7090. Alta appreciates the opportunity to provide geotechnical consulting services for your project.

Sincerely,
Alta California Geotechnical, Inc.

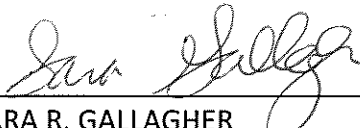
By: 
SARA R. GALLAGHER
Engineering Geology Associate

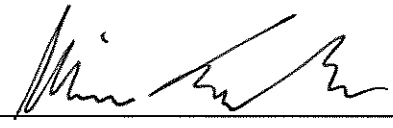

MINA TAWFIK
Civil Engineer Associate

Reviewed by:

SCOTT A. GRAY/RGE 2857
Reg. Exp.: 12-31-16
Registered Geotechnical Engineer
Vice President

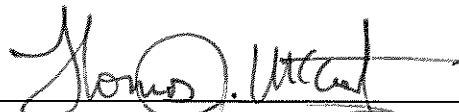

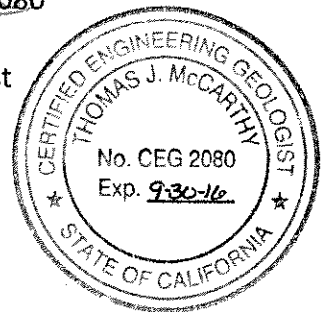
THOMAS J. MCCARTHY/CEG 2080
Reg. Exp.: 9-30-16
Certified Engineering Geologist
Vice President



Distribution: (3) Addressee

SRG: SAG: MT: TJM: skt-1-0152, April 14, 2015 (Prelim Geo Investigation, Armstrong Ranch)

Table of Contents

1.0 INTRODUCTION6

 1.1 Purpose6

 1.2 Scope of Work.....6

 1.3 Report Limitations.....7

2.0 PROJECT DESCRIPTION.....7

 2.1 Site Location and Existing Conditions7

 2.2 Proposed Development7

3.0 SITE INVESTIGATION8

 3.1 Previous Subsurface Investigation and Laboratory Testing8

 3.2 Current Subsurface Investigation8

4.0 GEOLOGIC CONDITIONS.....9

 4.1 Geologic and Geomorphic Setting9

 4.2 Stratigraphy.....9

 4.2.1 Artificial Fill - undocumented (map symbol afu)9

 4.2.2 Topsoil (no map symbol).....9

 4.2.3 Young alluvial-fan deposits (map symbol Qyf)10

 4.3 Geologic Structure10

 4.3.1 Tectonic Framework10

 4.3.2 Regionally Mapped Active Faults.....11

 4.3.3 Geologic Structure11

 4.4 Groundwater.....11

 4.5 Earthquake Hazards11

 4.5.1 Local and Regional Faulting12

 4.5.2 Liquefaction12

 4.5.3 Surface Rupture13

 4.5.4 Seiches13

 4.5.5 Tsunami.....13

 4.5.6 Dry Sand Settlement14

 4.5.7 Seismically Induced Landsliding.....14

5.0 ENGINEERING PROPERTIES AND ANALYSIS14

 5.1 Materials Properties14

 5.1.1 Excavation Characteristics14

 5.1.2 Hydro-Consolidation14

 5.1.3 Compressibility.....15

 5.1.4 Expansion Potential15

5.1.5	Shear Strength Characteristics.....	15
5.1.6	Earthwork Adjustments	16
5.1.7	Chemical Analyses.....	16
5.1.8	Pavement Support Characteristics	17
5.2	Engineering Analysis	17
5.2.1	Bearing Capacity and Lateral Earth Pressures	17
6.0	CONCLUSIONS AND RECOMMENDATIONS.....	17
6.1	General Earthwork Recommendations.....	18
6.1.1	Demolition of Existing Improvements	18
6.1.2	Site Preparation	18
6.1.3	Unsuitable Soil Removals.....	18
6.1.4	Over-excavation	19
6.1.5	Compaction Standards.....	20
6.1.6	Organic Content	20
6.1.7	Groundwater/Seepage	21
6.1.8	Documentation of Removals	21
6.1.9	Treatment of Removal Bottoms	22
6.1.10	Fill Placement.....	22
6.1.11	Benching.....	22
6.1.12	Mixing.....	22
6.1.13	Import Soils	22
6.1.14	Fill Slope Construction	23
6.1.15	Utility Trenches	24
6.1.16	Backcut Stability.....	25
6.2	Infiltration Type WQMP Systems.....	26
6.3	Methane Testing.....	26
7.0	DESIGN CONSIDERATIONS	26
7.1	Structural Design.....	26
7.1.1	Foundations	27
7.1.2	Conventional Foundation Systems	27
7.1.3	Post-Tensioned Slabs/Foundation Design Recommendations.....	29
7.2	Moisture Barrier.....	29
7.3	Seismic Design.....	30
7.4	Retaining Wall Design	30
7.5	Fence and Garden Walls	32
7.6	Footing Excavations	32
7.7	Exterior Slabs and Walkways	32
7.7.1	Subgrade Compaction.....	33
7.7.2	Subgrade Moisture	33

7.7.3	Concrete Slab Thickness	33
7.7.4	Concrete Slab Reinforcement	33
7.7.5	Control Joints	33
7.8	Concrete Design	34
7.9	Corrosion.....	34
7.10	Pavement Design	34
7.11	Site Drainage	35
7.12	Deepend Footings and Setbacks.....	35
8.0	FUTURE PLAN REVIEWS	37
9.0	CLOSURE.....	37
9.1	Geotechnical Review.....	37
9.2	Limitations.....	38

APPENDIX A: REFERENCES

APPENDIX B: SUBSURFACE INVESTIGATION

APPENDIX B-1: PREVIOUS SUBSURFACE INVESTIGATION

APPENDIX C: LABORATORY TESTING

APPENDIX C-1: PREVIOUS LABORATORY TESTING

APPENDIX D: EARTHWORK SPECIFICATIONS

APPENDIX E: STANDARD PLATES

1.0 INTRODUCTION

This report contains Alta California Geotechnical, Inc.'s (Alta's) findings, conclusions, and geotechnical recommendations for the development of the proposed Armstrong Ranch residential project.

1.1 Purpose

The purpose of this report is to examine the existing geotechnical conditions and evaluate their impact on the proposed residential development that is conceptually depicted on the enclosed site plan (Plate 1). This report is intended to be suitable for submittal to governing agencies and for use as a contractor bid document.

1.2 Scope of Work

Alta's *Scope of Work* for this geotechnical investigation includes the following:

- Reviewing the referenced reports pertinent to the subject site;
- Incorporating data generated from a previous field investigation and laboratory analyses conducted by GeoKinetics (2004) into this report;
- Excavating, logging, and sampling thirty (30) backhoe excavations to a maximum of 10.5 feet below the existing surface (Appendix B);
- Excavating, logging, and sampling four (4) hollow-stem auger excavations to a maximum of 10 feet below the existing surface (Appendix B);
- Conducting four (4) infiltration tests;
- Conducting laboratory testing on samples obtained during our investigation (Appendix C);
- Evaluating geologic and laboratory data to develop recommendations for site grading, foundations, and utilities;
- Preparing this report and accompanying exhibits.

1.3 Report Limitations

The conclusions and recommendations in this report are based on the information generated during this investigation, our review of the referenced reports, and our review of the conceptual site plan. The materials immediately adjacent to or beneath those observed may have different characteristics than those observed and no representations are made as to the quality or extent of materials not observed.

2.0 PROJECT DESCRIPTION

2.1 Site Location and Existing Conditions

The irregular-shaped, 112+-acre site is located southwest of the intersection of Riverside Drive and the Cucamonga Channel, in the City of Ontario. The site is bounded to the north by Riverside Drive, to the northeast by agricultural land, to the east by Cucamonga Channel, to the south by Chino Avenue, to the southwest by Vineyard Avenue, and to the northwest by agricultural land.

Past land use consisted of agriculture and dairy operations. A review of historic aerial photographs (Historic Aerials, 2015), indicates that the agricultural operations onsite extend at least as far back as 1938. The dairy operation started sometime between 1966 and 1980.

Dairy operations have ceased, but the infrastructure remains, including concrete feed lines, barns, concrete slabs, and fences. The southwest portion of the site is currently used for agricultural purposes. There is a truck storage yard in the proposed Planning Area 1. The single-family residential structures onsite are occupied and there are horse corrals in the southeast corner of the site.

2.2 Proposed Development

Approximately 624 residential lots with associated interior streets and infrastructure are proposed. A school site is proposed in the southeast corner of

the property. Minimal slopes are proposed and are estimated to be less than 5 feet high.

3.0 SITE INVESTIGATION

3.1 Previous Subsurface Investigation and Laboratory Testing

Alta has reviewed the referenced preliminary geotechnical report by GeoKinetics. Twelve (12) hollow-stem auger borings, fifty (50) shallow hand auger borings (testing for organic content), and nine (9) backhoe test pits were excavated, logged, and sampled as part of their subsurface investigation. The locations of the hollow-stem auger borings and test pits are shown on the attached Plate 1 and the logs are presented in Appendix B-1 of this report. Laboratory test results, including the organic test results from the hand auger borings, are presented in Appendix C-1.

3.2 Current Subsurface Investigation

Alta conducted a subsurface investigation of the Armstrong Ranch property in March of 2015. The investigation consisted of the excavation, logging, and selective sampling of thirty (30) backhoe test pits and the drilling of four (4) hollow-stem auger borings to evaluate the infiltration characteristics of the native soils. The locations of the infiltration borings and test pits are shown on the attached Plate 1 and the logs are presented in Appendix B of this report.

Laboratory testing was performed on bulk samples obtained during the field investigation. A brief description of laboratory test procedures and the test results are presented in Appendix C.

Access to Planning Area 1 and the school site was not available at the time of our investigation. Further discussion of this issue is presented in Section 8.0.

4.0 GEOLOGIC CONDITIONS

4.1 Geologic and Geomorphic Setting

Regionally, the site is located in the Peninsular Ranges geomorphic province, which characterizes the southwest portion of southern California. The Peninsular Ranges province is composed of plutonic and metamorphic rock, lesser amounts of Tertiary volcanic and sedimentary rock, and Quaternary drainage in-fills and sedimentary veneers. The proposed project is located in the Riverside sub-block (Jennings and Bryant, 2010), which is bounded by the Elsinore fault zone to the west and by the San Jacinto fault zone to the east.

4.2 Stratigraphy

A digital preparation of geologic mapping by Morton and Miller (2003) depicts the Armstrong Ranch project to be underlain by middle Holocene age "Young alluvial-fan deposits." Thin veneers of topsoil cover a majority of the property. A stockpile of artificial fill exists along the south central property line. The pile is approximately 800 feet in length, 100 feet wide, and approximately 15 feet high at the tallest point. The geologic units are briefly described below. Their distribution is shown on enclosed Plate 1.

4.2.1 Artificial Fill - undocumented (map symbol afu)

The materials are composed of brown, fine grained silty sand with some cobbles in a dry and loose to dense condition.

4.2.2 Topsoil (no map symbol)

Topsoil blankets much of the site and has been disturbed by agricultural cultivation. Topsoil consists primarily of brown, moist, loose, fine silty sand. Organics, including mulch and manure, are present in the top one-half foot in some locations. The average thickness of the topsoil is one foot.

4.2.3 Young alluvial-fan deposits (map symbol Qyf)

Middle Holocene-aged surficial deposits, termed "Young alluvial-fan deposits" by Morton and Miller (2003), underlie the site. The deposits observed at the site consist primarily of fine-grained, silty sands and fine- to medium-grained sand. The unit is brown, gray, or yellowish brown, moist, and moderately dense.

4.3 Geologic Structure

4.3.1 Tectonic Framework

Jennings and Bryant (2010) defined eight structural provinces within California that have been classified by predominant regional fault trends and similar fold structure. These provinces are in turn divided into blocks and sub-blocks that are defined by "major Quaternary faults". These blocks and sub-blocks exhibit similar structural features. Within this framework, the subject site is located within Structural Province I, which is controlled by the dominant northwest trend of the San Andreas Fault and is divided into two blocks, the Coast Range Block and the Peninsular Range Block. The Peninsular Range Block, on which this site is located, is characterized by a series of parallel, northwest trending faults that exhibit right lateral dip-slip movement. These faults are terminated by the Transverse Range block to the north and extend southward to the Baja Peninsula. These northwest trending faults divide the Peninsular Range block into eight sub-blocks. The Riverside Sub-block, one of the eight sub-blocks, is bound on the west by the Elsinore fault zone and on the east by the San Jacinto fault zone.

The site is located on the northwest portion of the Riverside sub-block, approximately 6.6 miles from the Chino-Central Avenue fault, 8.3 miles

from the San Jose fault, 9.7 miles from the Cucamonga fault, 10.7 miles from the Sierra Madre fault, and 11.3 miles from the Elsinore fault. The property is not within an Alquist-Priolo earthquake fault zone.

4.3.2 Regionally Mapped Active Faults

Several other large, active fault systems, including the Whittier, San Jacinto, Sierra Madre and San Andreas faults, occur in the region surrounding the subject site. These fault systems have been studied extensively and in a large part control the geologic structure of southern California.

4.3.3 Geologic Structure

Based upon our site investigation and literature review, the onsite alluvial deposits have not been folded, faulted or fractured. The deposits are typically massive with erosion/infill contacts and repeating fining upwards sequences.

4.4 Groundwater

Groundwater was not encountered during this firm's subsurface investigation or by Geokinetics during their subsurface investigation in 2004. Groundwater in the vicinity is generally at a depth of approximately 190 feet, based on available data from a water well located approximately 2.5 miles from the site (Department of Water Resources, 2015).

4.5 Earthquake Hazards

The subject site is located in southern California, which is a tectonically active area. The type and magnitude of seismic hazards affecting a site are dependent on the distance to the causative fault and the intensity and magnitude of the seismic event. The seismic hazard may be primary, such as surface rupture

and/or ground shaking, or secondary, such as liquefaction and/or ground lurching.

4.5.1 Local and Regional Faulting

The nearest active fault is the Chino-Central Avenue fault, which is located approximately 6.6 miles to the west. This fault has been identified as a Fault Rupture Hazard Zone by the State of California (Hart, 2007). "Active" faults have not been identified on the Armstrong ranch site, and therefore the probability of primary surface rupture or deformation at the site is considered unlikely.

Ground shaking hazards caused by earthquakes along the Chino fault and other active regional faults do exist. The 2013 California Building Code requires use-modified spectral accelerations and velocities for most structural designs. Seismic design parameters using soil profile types identified in the 2013 California Building Code are presented in Section 7.3.

4.5.2 Liquefaction

Seismic agitation of relatively loose saturated sands, silty sands, and some silts can result in a buildup of pore pressure. If the pore pressure exceeds the overburden stresses, a temporary quick condition known as liquefaction can occur. Liquefaction effects can manifest in several ways including: 1) loss of bearing; 2) lateral spread; 3) dynamic settlement; and 4) flow failure. Lateral spreading has typically been the most damaging mode of failure.

In general, the more recent that a sediment has been deposited, the more likely it will be susceptible to liquefaction. Other factors that must

be considered are: groundwater, confining stresses, relative density, and the intensity and duration of seismically-induced ground shaking.

Due to the depth to groundwater (approximately 190 feet below the existing ground surface), the potential for liquefaction to occur based on the existing conditions is nil. There may be some potential for localized liquefaction if infiltration-type WQMP systems are utilized onsite.

Further discussion of this potential is presented in Section 6.2.

4.5.3 Surface Rupture

Surface rupture is a break in the ground surface during or as a consequence of seismic activity. The potential for surface rupture at the site may be considered remote.

4.5.4 Seiches

A seiche is a free or standing-wave oscillation on the surface of water in an enclosed or semi-enclosed basin. The wave can be initiated by an earthquake and can vary in height from several centimeters to a few meters. The potential for a seiche impacting the property is considered to be non-existent.

4.5.5 Tsunami

A tsunami is a great sea wave produced by a submarine earthquake, landslide, or volcanic eruption. It is characterized by great speed of propagation and low observable amplitude on the open sea but can attain heights of several tens of feet upon encountering shallow water. Significant damage can occur along coastal areas subjected to such a wave. The site is not within the State of California Tsunami Inundation

Zone (Department of Conservation, 1997) due to the considerable distance from the coastline.

4.5.6 Dry Sand Settlement

Dry sand settlement is the process of non-uniform settlement of the ground surface during a seismic event. In consideration of the great depth of the groundwater and upon accomplishment of recommended removals, the potential for this type of settlement will be minimal.

4.5.7 Seismically Induced Landsliding

Due to a lack of slopes within or around the property seismically induced landsliding is not anticipated to pose a danger to the site.

5.0 ENGINEERING PROPERTIES AND ANALYSIS

5.1 Materials Properties

Presented herein is a general discussion of the engineering properties of the onsite materials that will be encountered during construction of the proposed project. Descriptions of the soil (Unified Soil Classification System) and in-place moisture/density results are presented on the boring logs in Appendix B.

5.1.1 Excavation Characteristics

Based on the data provided from the subsurface investigation, it is our opinion that the majority of the on-site materials possess favorable excavation characteristics.

5.1.2 Hydro-Consolidation

Hydro-consolidation is the effect of introducing water into soil that is prone to collapse. Upon loading and initial wetting, the soil structure and apparent strength are altered resulting in almost immediate settlement.

That settlement can have adverse impacts on engineered structures, particularly in areas where it is manifested differentially. Differential settlements are typically associated with differential wetting, irregularities in the subsurface soil conditions, or irregular loading patterns.

Based on a review of the previous testing conducted by Geokinetics (2004), there is a potential for hydro-collapse in the upper portions of the young alluvial fan deposit onsite. However, based on Alta's removal recommendations (Section 6.1.2), the potential for hydro-collapse to occur at the site will be low and within foundation design tolerances upon the completion of recommended unsuitable soil removals and recompaction.

5.1.3 Compressibility

The undocumented artificial fill and upper portions of the young alluvial fan deposits onsite are considered compressible and unsuitable to support the proposed improvements.

5.1.4 Expansion Potential

Expansion index testing was performed during the previous subsurface investigation (Geokinetics, 2004). Based on the results from the previous investigation, it is anticipated that the majority of materials onsite will vary in expansion potential from "low" to "medium".

5.1.5 Shear Strength Characteristics

Direct shear testing was performed during the previous subsurface investigation (Geokinetics, 2004) to assist in the development of shear strength characteristics of the onsite soils. The values presented in Table

5-1 are based on laboratory testing and our previous experience with similar geologic units.

TABLE 5-1 Shear Strength Characteristics		
Geologic Unit	Cohesion, C (psf)	Friction Angle, ϕ (degrees)
Engineered Artificial Fill	200	28

5.1.6 Earthwork Adjustments

The values presented in Table 5-2 are deemed appropriate for estimating purposes and may be used in an effort to balance earthwork quantities. As is the case with every project, contingencies should be made to adjust the earthwork balance when grading is in-progress and actual conditions are better defined.

TABLE 5-2 Earthwork Adjustment Factors		
Geologic Unit	Adjustment Factor Range	Recommended Average
Undocumented Artificial Fill/Topsoil	Shrink 12 to 16%	14%
Young alluvial fan Deposits	Shrink 8 to 12%	10%

5.1.7 Chemical Analyses

Chemical testing was performed during the previous subsurface investigation (Geokinetics, 2004), Soluble sulfate test results indicate that the soluble sulfate concentrations of the soils tested are classified as negligible per ACI 318-11 per the 2013 CBC (Category S0). Resistivity testing indicates that the soils are "severely corrosive" to buried metals (per Romanoff, 1989). Chloride concentrations of 69 ppm were detected onsite.

5.1.8 Pavement Support Characteristics

The onsite soils can be expected to provide moderate to good pavement support characteristics. Preliminary testing resulted in an R-Value of 62. Specific testing should be conducted upon completion of grading and be used as a basis for design of pavement.

5.2 Engineering Analysis

Presented below is a general discussion of the engineering analysis methods that were utilized to develop the conclusions and recommendations presented in this report.

5.2.1 Bearing Capacity and Lateral Earth Pressures

Ultimate bearing capacity values were obtained using the graphs and formula presented in NAVFAC DM-7.1. Allowable bearing was determined by applying a factor of safety of at least 3 to the ultimate bearing capacity. Static lateral earth pressures were calculated using Rankine methods for active and passive cases. If it is desired to use Coulomb forces, a separate analysis specific to the application can be conducted.

6.0 CONCLUSIONS AND RECOMMENDATIONS

Based on Alta's findings during our subsurface investigation, the previous field investigation, the laboratory test results, our staff's previous experience in the area, and a review of the proposed site plan, it is Alta's opinion that the development of the site is feasible from a geotechnical perspective. Presented below are recommendations that should be incorporated into site development and construction plans.

6.1 General Earthwork Recommendations

All grading shall be accomplished under the observation and testing of the project geotechnical consultant in accordance with the recommendations contained herein and the City of Ontario criteria.

6.1.1 Demolition of Existing Improvements

Remnants of past site use such as feeding pens, fencing, and dairy structures should be demolished and removed from the site.

Concrete may be crushed and reused in deeper (>10 feet below finish grade) fill areas, provided it is reduced in size such that the maximum dimension does not exceed the least dimension by more than two times and reinforcing steel is cut off at the face of the concrete.

6.1.2 Site Preparation

Vegetation, construction debris, manure, and other deleterious materials are unsuitable as structural fill material and should be disposed of off-site prior to commencing grading/construction.

6.1.3 Unsuitable Soil Removals

Presented below are the unsuitable soil removal recommendations for the onsite geologic units. Organics encountered in these units should be handled in accordance with the recommendations presented in Section 6.1.6. All removal bottoms should be observed by the Project Geotechnical Consultant in the field during grading to determine that suitable (non-weathered, limited porosity) soils have been exposed.

6.1.3.1 Artificial fill/Topsoil

The artificial fill/topsoil onsite is unsuitable to support the proposed fills and/or structures and should be removed and recompacted to project specifications. Removal bottoms should be observed by the Project Geotechnical Consultant in the field during grading to finally determine the depth of unsuitable soil removals.

6.1.3.2 Young alluvial fan deposits

The upper portions of the "Young alluvial fan deposits" are unsuitable to support the proposed fills and/or structures and should be removed and recompacted to project specifications. It is anticipated that the upper 4 to 5 feet of these deposits will require removal and recompaction. Removal bottoms should be observed by the Project Geotechnical Consultant in the field during grading to finally determine the depth of unsuitable soil removals.

6.1.4 Over-excavation

Lots should be underlain by a minimum of three (3) feet of compacted fill. As such, cut lots and the cut portion of transition lots should be over-excavated a minimum of three (3) feet in areas where the recommended removals do not provide the minimum amount of compacted fill. Over-excavations should be observed and approved by the Project Geotechnical Consultant in the field during grading.

6.1.5 Compaction Standards

All fill and processed natural ground shall be compacted to a minimum relative compaction of 90 percent, as determined by ASTM Test Method: D-1557. Fill material should be moisture conditioned to optimum moisture or above, and as generally discussed in Alta's Earthwork Specification Section presented in Appendix E. Compaction shall be achieved with the use of sheepsfoot rollers or similar kneading type equipment. Mixing and moisture conditioning will be required in order to achieve the recommended moisture conditions.

6.1.6 Organic Content

The amount of organic material that can be incorporated into fills should be limited. Geokinetics (2004) performed organic testing on the onsite soils in the project and the results are presented in Appendix C-1. The test results indicate that a majority of soils have an organic concentration of <1%.

Soils with organic concentrations greater than 1% can either be: 1) removed from the site; or 2) blended with soils with limited to no organics. This blending can be accomplished by repeatedly corner-plowing the material with a dozer as well as discing the material with a tractor-drawn disc. After blending, the soils can be disposed of in structural fill areas throughout the site at a rate of approximately 1 scraper load of blended material for each 10 scrapers loads of fill material placed. Once fill material is placed in structural fill areas, it should be thoroughly mixed with a tractor-

drawn disc, brought to above optimum moisture content, and compacted in-place to project specifications.

Periodic observation pits should be excavated during the rough grading. If any concentration of organics are detected during the excavation of the observation pits or compaction test pits, the area should be completely removed or re-mixed until no concentrations of organics are present.

Limited concentrations of manure were observed onsite and were primarily within the upper one foot of the topsoil. If large concentrations of manure are encountered during grading, this material will likely need to be disposed of offsite.

6.1.7 Groundwater/Seepage

It is anticipated that groundwater will not be encountered during grading/construction. It is possible that perched water conditions could be encountered depending on the time of year construction occurs.

6.1.8 Documentation of Removals

All removal/overexcavation bottoms should be observed and approved by the project Geotechnical Consultant prior to fill placement. Removal bottoms and undercuts should be surveyed after approval by the geotechnical consultant prior to the placement of fill. Staking should be provided in order to verify undercut locations and depths.

6.1.9 Treatment of Removal Bottoms

At the completion of removals/over-excavation, the exposed removal bottom should be ripped to a minimum depth of eight inches, moisture-conditioned to above optimum moisture content and compacted in-place to the project standards.

6.1.10 Fill Placement

After removals, scarification, and compaction of in-place materials are completed, additional fill may be placed. Fill should be placed in eight-inch bulk maximum lifts, moisture conditioned to optimum moisture content or above, compacted and tested as grading/construction progresses until final grades are attained.

6.1.11 Benching

Where the natural slope is steeper than 5-horizontal to 1-vertical and where designated by the project Geotechnical Consultant, compacted fill material shall be keyed and benched into competent bedrock or firm artificial fill.

6.1.12 Mixing

Mixing of materials may be necessary to prevent layering of different soil types and/or different moisture contents. The mixing should be accomplished prior to and as part of compaction of each fill lift.

6.1.13 Import Soils

Import soils, if necessary, should consist of clean, low expansive, structural quality, compactable materials similar to the on-site soils and should be free of trash, debris or other objectionable

materials. The project Geotechnical Consultant should be notified not less than 72 hours in advance of the locations of any soils proposed for import. Import sources should be sampled, tested, and approved by the project Geotechnical Consultant at the source prior to the importation of the soils to the site. The project Civil Engineer should include these requirements on plans and specifications for the project.

6.1.14 Fill Slope Construction

Fill slopes should be overfilled to an extent determined by the contractor, but not less than two (2) feet measured perpendicular to the slope face, so that when trimmed back to the compacted core a minimum 90 percent relative compaction is achieved.

Compaction of each fill lift should extend out to the temporary slope face. Back-rolling during mass filling at intervals not exceeding four (4) feet in height is recommended, unless more extensive overfilling is undertaken.

As an alternative to overfilling, fill slopes may be built to the finish slope face in accordance with the following recommendations:

1. Compaction of each fill lift should extend to the face of the slopes.
2. Back-rolling during mass grading should be undertaken at intervals not exceeding four (4) feet in height. Back-rolling at more frequent intervals may be required.
3. Care should be taken to avoid spillage of loose materials down the face of any slopes during grading. Spill fill will require complete removal prior to compaction, shaping, and grid rolling.

4. At completion of mass filling, the slope surface should be watered, shaped, and compacted by track walking with a D-8 bulldozer, or equivalent, such that compaction to project standards is achieved to the slope face.

Proper seeding and planting of the slopes should follow as soon as practical to inhibit erosion and deterioration of the slope surfaces. Proper moisture control will enhance the long-term stability of the finish slope surface.

6.1.15 Utility Trenches

6.1.15.1 Excavation

Utility trenches should be supported, either by laying back excavations or shoring, in accordance with applicable OSHA standards. In general, existing site soils are classified as Soil Types "B" and "C" per OSHA standards. Upon completion of the recommended removals and recompaction, the artificial fill will be classified as Soil Type "B". The Project Geotechnical Consulting should be consulted if geologic conditions vary from what is presented in this report. Flatter backcuts or shoring may be required depending on the depth of the utility lines.

6.1.15.2 Backfill

Trench backfill should be compacted to at least 90 percent of maximum dry density as determined by ASTM D-1557.

Onsite soils will not be suitable for use as bedding material but will be suitable for use in backfill provided oversized materials are removed. No surcharge loads should be imposed above excavations. This includes spoil piles, lumber,

concrete trucks, or other construction materials and equipment. Drainage above excavations should be directed away from the banks. Care should be taken to avoid saturation of the soils. Compaction should be accomplished by mechanical means. Jetting of native soils will not be acceptable.

6.1.16 Backcut Stability

Temporary backcuts, if required during unsuitable soil removals, should be made no steeper than 1:1 without review and approval of the geotechnical consultant. Flatter backcuts may be necessary where geologic conditions dictate and where minimum width dimensions are to be maintained.

Care should be taken during remedial grading operations in order to minimize risk of failure. Should failure occur, complete removal of the disturbed material will be required.

In consideration of the inherent instability created by temporary construction backcuts for stabilization fills and removals, it is imperative that grading schedules are coordinated to minimize the unsupported exposure time of these excavations. Once started these excavations and subsequent fill operations should be maintained to completion without intervening delays imposed by avoidable circumstances. In cases where five-day workweeks comprise a normal schedule, grading should be planned to avoid exposing at-grade or near-grade excavations through a non-work weekend. Where improvements may be affected by temporary instability, either on or offsite, further restrictions such as slot

cutting, extending work days, implementing weekend schedules, and/or other requirements considered critical to serving specific circumstances may be imposed.

6.2 Infiltration Type WQMP Systems

It is Alta's understanding that infiltration basins are going to be utilized onsite for storm water control. Alta will prepare an infiltration study report utilizing the testing conducted as part of our investigation once the design is available. However, it should be noted that utilization of infiltration-type systems onsite could increase the potential for localized liquefaction around the basins. Post-tensioned slabs may be recommended for structures adjacent to the basins.

6.3 Methane Testing

Preliminary methane testing was discussed as part of the previous Phase 1 environmental report (GeoKinetics, 2012). Elevated levels of methane were detected in six of the forty-two probe locations onsite. Based on City of Ontario specifications, it should be anticipated that a post-grading methane study will need to be conducted onsite. Methane mitigation measures, such as enhanced vapor barriers or vent lines may be necessary if levels exceed controlling authority limits.

7.0 DESIGN CONSIDERATIONS

7.1 Structural Design

It is anticipated that a one to two-story, wood-frame and masonry residential structure with slab on-grade and shallow foundations will be constructed. Upon the completion of rough grading, finish grade samples should be collected and tested in order to provide specific recommendations as they relate to the individual building pad. These test results and corresponding design

recommendations should be presented in a final rough grading report. Final slab and foundation design recommendations should be made based upon specific structure sitings, loading conditions, and as-graded soil conditions.

It is anticipated that the majority of onsite soils will possess "low" to "medium" expansion potential when tested in general accordance with ASTM Test Method D: 4829. Recommendations for conventional and post-tensioned slabs/foundation systems are presented below. As discussed in Section 6.3, post-tensioned slabs may be recommended for structures in the vicinity of infiltration-type WQMP systems.

7.1.1 Foundations

Foundations may be preliminary designed based on the values presented in Table 7-1 below.

Table 7-1 Foundation Design Parameters*	
Allowable Bearing	2000 lbs/ft ²
Lateral Bearing	250 lbs/ft ² at a depth of 12 inches plus 250 lbs/ft ² for each additional 12 inches of embedment to a maximum of 2000 lbs/ft ²
Sliding Coefficient	0.30
Differential Settlement	Dynamic: Differential = 1 inch in 40 feet Static: Differential = 0.75 inch in 40 feet

*These values may be increased as allowed by Code to resist transient loads such as wind or seismic. Building code and structural design considerations may govern depth and reinforcement requirements and should be evaluated.

7.1.2 Conventional Foundation Systems

Based on the onsite soils conditions and information supplied by the CBC 2013, conventional foundation systems may be designed in accordance with Tables 7-1 and 7-2.

TABLE 7-2 CONVENTIONAL FOUNDATION DESIGN PARAMETERS		
Expansion Potential	<i>Very Low to Low</i>	<i>Medium</i>
Soil Category	I	II
Design Plasticity Index	10	20
Minimum Outer Footing Embedment	12 inches*	18 inches*
<p>*The minimum footing embedments presented herein are based on expansion indexes. The structural engineer should determine minimum embedments based on the number of floors supported by the footings, the structural loading, and the requirements of the latest California Building Code.</p>		
Minimum Footing Width	12-inches-The structural engineer should determine the minimum footing width based on loading and the latest California Building Code.	
Footing Reinforcement	No. 4 rebar, one (1) on top, one (1) on bottom	No. 4 rebar, one (1) on top, one (1) on bottom
Slab Thickness	4 inches (actual)	4 inches (actual)
Slab Reinforcement	No. 3 rebar spaced 18 inches on center, each way	No. 3 rebar spaced 15 inches on center, each way
Under-Slab Requirement	See Section 7.2	See Section 7.2
Slab Subgrade Moisture	Minimum of 110 percent of optimum moisture to a depth of 12 inches prior to placing concrete.	Minimum of 120 percent of optimum moisture to a depth of 12 inches prior to placing concrete.
Footing Embedment Adjacent to Swales and Slopes	If exterior footings adjacent to drainage swales are to exist within five (5) feet horizontally of the swale, the footing should be embedded sufficiently to assure embedment below the swale bottom is maintained. Footings adjacent to slopes should be embedded such that at least five- (5) feet is provided horizontally from edge of the footing to the face of the slope.	
Garages	A grade beam reinforced continuously with the garage footings shall be constructed across the garage entrance, tying together the ends of the perimeter footings and between individual spread footings. This grade beam should be embedded at the same depth as the adjacent perimeter footings. A thickened slab, separated by a cold joint from the garage beam, should be provided at the garage entrance. Minimum dimensions of the thickened edge shall be six (6) inches deep. Footing depth, width and reinforcement should be the same as the structure. Slab thickness, reinforcement and under-slab treatment should be the same as the structure.	

7.1.3 Post-Tensioned Slabs/Foundation Design Recommendations

Post-tensioned slabs for the project may be preliminarily designed utilizing the parameters presented in Tables 7-1 and 7-3. The parameters presented herein are based on methodology provided in the Design of Post-Tensioned Slabs-On-Ground, Third Edition, by the Post-Tensioning Institute, in accordance with the 2013 CBC.

TABLE 7-3 POST-TENSION SLAB DESIGN PARAMETERS						
Category	Expansion Potential	Minimum Embedment*	Edge Lift		Center Lift	
			Em (ft)	Ym (inch)	Em (ft)	Ym (inch)
I	Low	12 inches	5.4	0.61	9.0	0.26
II	Medium	18 inches	5.2	1.10	9.0	0.46
Slab Subgrade Moisture						
Category I		Minimum 110% of optimum moisture to a depth of 12 inches prior to pouring concrete				
Category II		Minimum 120% of optimum moisture to a depth of 12 inches prior to pouring concrete				
Embedment*						
The minimum footing embedments presented herein are based on expansion indexes. The structural engineer should determine minimum embedments based on the number of floors supported by the footings, the structural loading, and the requirements of the latest California Building Code. If mat slabs are utilized, alternate embedment depths can be provided.						
Moisture Barrier						
A moisture barrier should be provided in accordance with the recommendations presented in Section 7.2						
<i>The parameters presented herein are based on procedures presented in the <u>Design of Post-Tensioned Slabs-On-Ground, Third Edition</u>. No corrections for vertical barriers at the edge of the slab, or for adjacent vegetation have been assumed. The design parameters are based on a Constant Suction Value of 3.9 pF.</i>						

7.2 Moisture Barrier

A moisture and vapor retarding system should be placed below the slabs-on-grade in portions of the structure considered to be moisture sensitive and should be capable of effectively preventing the migration of water and reducing the transmission of water vapor to acceptable levels. Historically, a 10-mil plastic

membrane, such as Visqueen, placed between one to four inches of clean sand, has been used for this purpose. The use of this system or other systems can be considered, at the discretion of the designer, provided the system reduces the vapor transmission rates to acceptable levels.

7.3 Seismic Design

The following seismic design parameters are presented to be code compliant to the California Building Code (2013). The site has been identified as "D" site class in accordance with CBC, 2013, Table 1613.5.3 (1). Utilizing this information, the computer program USGS Seismic Design Maps Version 3.1.0 and ASCE 7-10 criterion, the spectral response accelerations are as follows.

Ss (period 0.2 sec)	1.500
SMs (period 0.2 sec)	1.500
SDs (period 0.2 sec)	1.000
S1 (period 1.0 sec)	0.600
SM1 (period 1.0 sec)	0.900
SD1 (period 1.0 sec)	0.600

These parameters should be verified by the structural engineer. Additional parameters should be determined by the structural engineer based on the Occupancy Category of the proposed structures.

7.4 Retaining Wall Design

Retaining walls should be founded on compacted fill and should be backfilled with granular soils that allow for drainage behind the wall. Foundations may be designed in accordance with the recommendations presented in Table 7-1, above. Unrestrained walls, free to rotate at least 0.001 radians, may be designed to resist lateral pressures imposed by a fluid with a unit weight determined in accordance with the Table 7-4 below. The table also presents

design parameters for restrained (at-rest) retaining walls. These parameters may be used to design retaining walls that may be considered as restrained due to the method of construction or location (corner sections of unrestrained retaining walls).

Backfill	Active (psf/ft)	At-Rest (psf/ft)
Level	38	59
2:1	59	106

Per the requirements of the 2013 CBC, the seismic force acting on the retaining walls may be resolved utilizing the formula $19H^2$ lb/lineal ft (H =height of the wall). This force acts at approximately $0.67H$ above the base of the wall.

- Restrained retaining walls should be designed for “at-rest” conditions.
- The design loads presented in the above table are to be applied on the retaining wall in a horizontal fashion and as such friction between wall and retained soils should not be allowed in the retaining wall analyses.
- Additional allowances should be made in the retaining wall design to account for the influence of construction loads, temporary loads, and possible nearby structural footing loads.
- Select backfill should be granular, structural quality backfill with a Sand Equivalent of 20 or better and an ASCE Expansion Index of 20 or less. The backfill must encompass the full active wedge area; otherwise, the values presented in the Native Backfill column must be used for the design. Native backfill should have an ASCE Expansion Index of 50 or less. The upper one foot of backfill should be comprised of native on-site soils (see Plate A).
- The wall design should include waterproofing (where appropriate) and backdrains or weep holes for relieving possible hydrostatic pressures. The backdrain should be comprised of a 4-inch perforated PVC pipe in a 1 ft. by 1 ft., $\frac{3}{4}$ -inch gravel matrix, wrapped with a geofabric. The backdrain should be installed with a minimum gradient of 2 percent and should be outletted to an appropriate location.

RETAINING WALL BACKFILL DETAIL

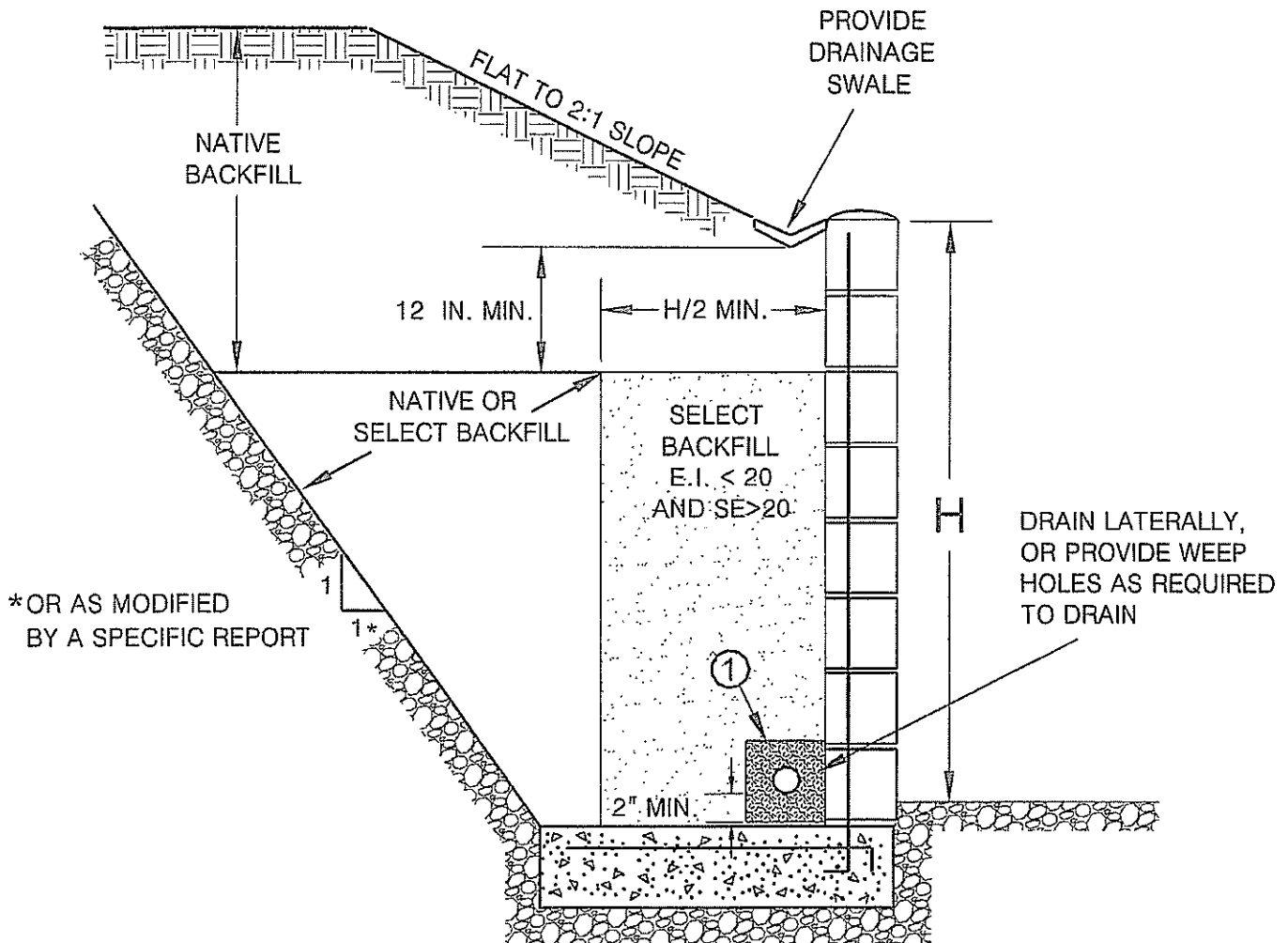

①

PIPE: 4-INCH PERFORATED PVC, SCHEDULE 40, SDR35 OR APPROVED ALTERNATE
 MINIMUM 8 PERFORATIONS (1/4-IN. DIA.) PER LINEAL FT. IN BOTTOM HALF OF PIPE

ROCK: MINIMUM VOLUME OF 1 CU. FT. OF 3/4-IN. MAX. ROCK PER. LINEAL FOOT OF PIPE, OR APPROVED ALTERNATE

FILTER FABRIC: MIRAFI 140 FILTER FABRIC OR APPROVED EQUIVALENT



ALTA CALIFORNIA GEOTECHNICAL, INC.
 VER. 1/10

PLATE A

- No backfill should be placed against concrete until minimum design strengths are achieved in compression tests of cylinders.

It should be noted that the allowable bearing and passive resistance values presented in Table 7-1 are based on level conditions at the toe. Modified design parameters can be presented for retaining walls with descending slope conditions at the toe.

7.5 Fence and Garden Walls

Block walls, if used, should be embedded a minimum of 2 feet below the lowest adjacent grade. In the vicinity of descending slopes, the foundations should be embedded to provide for a minimum distance of $H/6$ (where H is the height of the slope) from the face of the slope to the outside edge of the bottom of the footing (to a maximum of 20 feet).

Construction joints (not more than 20 feet apart) should be included in the block wall construction. Side yard walls should be structurally separated from the rear yard wall.

7.6 Footing Excavations

Soils from the footing excavations should not be placed in slab-on-grade areas unless properly compacted and tested. The excavations should be cleaned of all loose/sloughed materials and be neatly trimmed at the time of concrete placement.

7.7 Exterior Slabs and Walkways

Exterior concrete slabs and walkways should be designed and constructed in consideration of the following recommendations.

7.7.1 Subgrade Compaction

The subgrade below exterior concrete slabs should be compacted to a minimum of 90 percent relative compaction as determined by ASTM Test Method: D 1557.

7.7.2 Subgrade Moisture

The subgrade below concrete slabs should be moisture conditioned to a minimum of 110 percent of optimum moisture content (low expansion) or 120 percent of optimum moisture (medium expansion) prior to concrete placement.

7.7.3 Concrete Slab Thickness

Concrete flatwork and driveways should be designed utilizing four-inch minimum thickness.

7.7.4 Concrete Slab Reinforcement

Utilization of reinforcement for flatwork and driveways is subject to a cost/benefit analysis. Reinforcement will decrease the amount of cracking that may occur in flatwork, however, planning for occasional repairs may be more cost effective. Utilizing closely spaced control joints is likely more cost-effective than utilizing reinforcement. The majority of the soils onsite are classified as low to medium in expansion potential. Consideration should be given to reinforcing flatwork with irregular (non-square/rectangular) shapes.

7.7.5 Control Joints

Weakened plane joints should be installed on walkways at intervals of approximately eight feet (maximum) or less. Exterior slabs should be designed to withstand shrinkage of the concrete.

7.8 Concrete Design

As stated in Section 5.1.6, negligible concentrations of sulfates were detected in the onsite soils. Therefore, the use of sulfate resistant concrete is not required per ACI 318-11. Post-grading conditions should be evaluated and final recommendations made at that time.

7.9 Corrosion

Based on preliminary testing, the onsite soils are corrosive to buried metal objects. Buried ferrous metals should be protected against the effects of corrosive soils in accordance with the manufacture's recommendations. Typical measures may include using non-corrosive backfill, protective coatings, wrapping, plastic pipes, or a combination of these methods. A corrosion engineer should be consulted if specific design recommendations are required by the improvement designer.

Per ACI 318-11, an exposure class of C1 would be applicable to metals encased in concrete (rebar in footings) due to being exposed to moisture from surrounding soils.

7.10 Pavement Design

Pavement sections for the proposed streets should be designed based on laboratory testing conducted on samples taken from the soil subgrade.

Preliminarily, based on an assumed R-Value of 50 and a traffic index of 5.5, the streets may be designed utilizing a pavement section of 4-inches of asphalt over 6-inches of aggregate base (City of Ontario minimum). This section should be verified upon the completion of grading, based on R-Value testing.

Construction of the streets should be accomplished in accordance with the current criteria of the City of Ontario and under the observation and testing of the Project Geotechnical Consultant.

Prior to the placement of base material, the subgrade should be suitably moisture conditioned, processed and compacted to a minimum 95 percent of the laboratory maximum density (ASTM: D 1557) to at least twelve (12) inches below subgrade. After subgrade compaction, the exposed grade should then be "proof"-rolled with heavy equipment to ensure the grade does not "pump" and is verified as non-yielding. Aggregate base material should be placed on the compacted subgrade and compacted in-place to a minimum 95 percent of the laboratory standard obtained per ASTM: D 1557.

7.11 Site Drainage

Positive drainage away from the proposed structures should be provided and maintained. Roof, pad and lot drainage should be collected and directed away from the structures toward approved disposal areas through drainage terraces, gutters, down drains, and other devices. Design fine grade elevations should be maintained through the life of the structure or if design fine grade elevations are altered, adequate area drains should be installed in order to provide rapid discharge of water, away from structures. Residents or Homeowner Associations should be made aware that they are responsible for maintenance and cleaning of all drainage terraces, down drains, and other devices that have been installed to promote site and structure drainage.

7.12 Deepend Footings and Setbacks

It is generally recognized that improvements constructed in proximity to properly constructed slopes can, over a period of time, be affected by natural processes including gravity forces, weathering of surficial soils and long term

(secondary) settlement. Most building codes, including the California Building Code (CBC), require that structures be set back or footings deepened, where subject to the influence of these natural processes. For the subject site, where foundations for residential structures are to exist in proximity to slopes, the footings should be embedded to satisfy the requirements presented in the following figure.

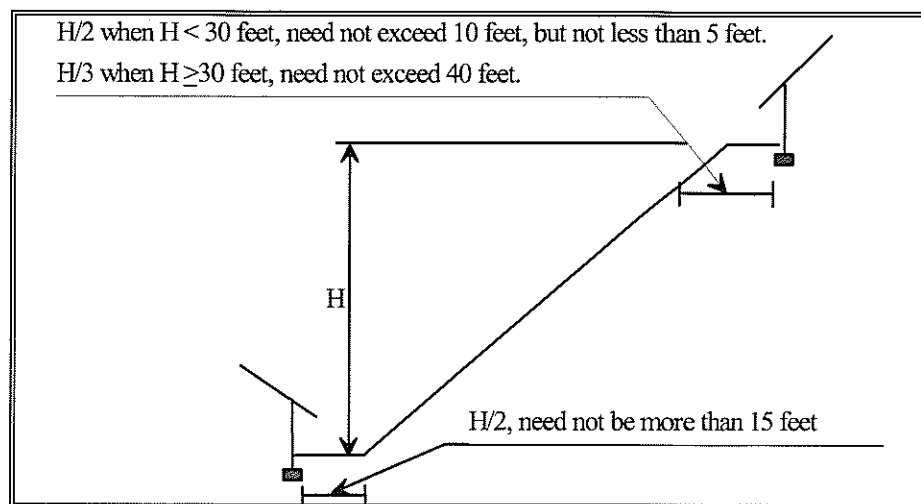

Consideration of these natural processes should be undertaken in the design and construction of other improvements. Homeowners are advised to consult with qualified geotechnical engineers, designers, and contractors in the design and construction of future improvements. Each lot and proposed improvement should be evaluated in relation to the specific site conditions, accounting for the hillside nature and specific soil conditions. Suggested homeowner and improvement considerations are provided in the Appendix of this report.

8.0 FUTURE PLAN REVIEWS

This report represents a geotechnical review of the conceptual site plan. As the project design progresses, site specific geologic and geotechnical issues should be considered in the design and construction of the project. Consequently, future plan reviews may be necessary. These reviews may include reviews of:

- Grading Plans
- Foundation Plans
- Utility Plans

These plans should be forwarded to the project Geotechnical Consultant for review.

As noted in Section 3.2, the proposed P.A. 1 and school site areas were not accessible during the current or previous subsurface investigations. It is anticipated that similar geotechnical conditions as to what was encountered throughout the remainder of the site will be present. As such, from a preliminary planning/design standpoint, the recommendations presented herein are suitable for use in these areas. However, a subsurface investigation and subsequent laboratory testing should be conducted in these areas to verify that the recommendations contained herein are suitable.

9.0 CLOSURE

9.1 Geotechnical Review

For the purposes of this report, multiple working hypotheses were established for the project, utilizing the available data and the most probable model is used for the analysis. Future information collected during the proposed grading operations is intended to evaluate the hypothesis and as such, some of the assumptions summarized in this report may need to be changed. Some modifications of the grading recommendations may become necessary, should

the conditions encountered in the field differ from the conditions hypothesized in this report.

Plans and sections of the project specifications should be reviewed by Alta, to evaluate conformance with the intent of the recommendations contained in this report. If the project description or final design varies from that described in herein, Alta must be consulted regarding the applicability of the recommendations contained herein and whether any changes are required. Alta accepts no liability for any use of its recommendations if the project description or final design varies and Alta is not consulted regarding the alterations.

9.2 Limitations

This report is based on the following: 1) the project as presented on the attached plan; 2) the information obtained from the subsurface investigation at the approximate locations indicated on the plan included herein; 3) laboratory test results; and 4) from the information presented in the referenced reports. The findings and recommendations are based on the results of the subsurface investigation, laboratory testing, and office analysis combined with an interpolation and extrapolation of conditions between and beyond the subsurface excavation locations. However, the materials adjacent to or beneath those observed may have different characteristics than those observed and no precise representations are made as to the quality or extent of the materials not observed. The findings are also based on information from previous investigations/geotechnical reports contained in the references. The results reflect an interpretation of the direct evidence obtained. Work performed by Alta has been conducted in a manner consistent with the level of care and skill ordinarily exercised by members of the geotechnical profession currently practicing in the same locality under similar conditions. No other representation,

either expressed or implied, and no warranty or guarantee is included or intended.

The recommendations presented in this report are based on the assumption that an appropriate level of field review will be provided by a geotechnical consultant who is familiar with the design and site geologic conditions. That field review shall be sufficient to confirm that geotechnical and geologic conditions exposed during grading are consistent with the geologic representations and corresponding recommendations presented in this report.

The conclusions and recommendations included in this report are applicable to the specific design of this project as discussed in this report. They have no applicability to any other project or to any other location and any and all subsequent users accept any and all liability resulting from any use or reuse of the data, opinions, and recommendations without the prior written consent of Alta.

Alta has no responsibility for construction means, methods, techniques, sequences, procedures, safety precautions, programs in connection with the construction, acts or omissions of the CONTRACTOR or any other person performing any of the construction, or for the failure of any of them to carry out the construction in accordance with the final design drawings and specifications.

APPENDIX A

REFERENCES

APPENDIX A

Selected References

- Bryant, W.A., and Hart, E.W., 2007, Fault Rupture Hazard Zones in California, Alquist-Priolo Earthquake Zoning Act with Index to Earthquake Fault Zones Map, Special Publication 42, interim revision, California Department of Conservation, California Geological Survey.
- California Division of Mines and Geology, 2008, Guidelines for evaluating and mitigating seismic hazards in California: Department of Conservation, Special Publication 117a.
- California Code of Regulations, 2013, California Building Code, Title 24, Part 2, Volume 2, Based on the 2012 International Building Code, Effective Date January 1, 2014.
- Department of Conservation, Division of Mines and Geology, 2000, Seismic Hazard Zone Report for the Ontario 7.5 minute Quadrangles, Los Angeles County California, Seismic Hazard Zone Report 040.
- Department of Water Resources, 2015, <http://www.water.ca.gov/waterdatalibrary/>, Station 340186N1175642W001, accessed April 10, 2015.
- Geokinetics Geotechnical & Environmental Engineers, 2012, Phase 1 Environmental Site Assessment, 9155 East Riverside Drive, Ontario, California, dated September 18, 2012.
- Geokinetics Geotechnical & Environmental Engineers, 2004, Preliminary Geotechnical Site Investigation, Deboer Property, 9155 East Riverside Drive, Ontario, California, dated December 8, 2004.
- Historic Aerials, 2015, <http://www.historicaerials.com/>, dates reviewed: 2012, 2005, 2002, 1994, 1980, 1966, 1959, 1948, 1938, copyright 2011, accessed April 10, 2015.
- Jennings, C. W., and Bryant, W.A., 2010, Fault activity map of California: California Geologic Survey geologic map no. 6, scale 1:750,000.
- Jennings, C. W., and Bryant, W.A., 2010, An explanatory text to accompany the Fault Activity Map of California: California Department of Conservation, California Geological Survey.
- Morton, D. M. and Miller, C. H., 2003, Preliminary Geologic Map of the San Bernardino 30' X 60' Quadrangle, California, Version 1.0: United States Geologic Survey, Open File Report 03-293.
- Rogers, Thomas H., 1965, California Division of Mines and Geology: Geologic Map of California, Santa Ana sheet, scale 1:250,000.
- Romanoff, Melvin, 1989, Underground Corrosion, NBS Circular 579, Reprinted by NACE, Houston, TX, 1989.

Project No. 1-0152
April 14, 2015

Page A-2

USGS, 2013, Seismic Design Maps.
<http://earthquake.usgs.gov/hazards/designmaps/usdesign.php>

APPENDIX B



Subsurface Investigation

APPENDIX B
Subsurface Investigation

Alta's subsurface investigation consisted of excavating, logging, and sampling thirty (30) backhoe test pits and four (4) hollow-stem auger borings. Details of the subsurface investigation are presented in Table B. The approximate locations of the exploratory excavations are shown on the accompanying site plan (Plate 1) and the Geotechnical Logs are attached. In-situ density/moisture testing was conducted utilizing a nuclear test gauge. The results are presented in Table B-1.

TABLE B SUBSURFACE INVESTIGATION DETAILS			
Equipment	Range of Depths	Sampling Methods	Sample Locations
Backhoe	5 to 10.5 feet	1. Bulk	1. Bulk-Select Depths
Hollow-Stem Auger	10 feet	1. Ring Sampler	1. Ring-Select Depths

UNIFIED SOIL CLASSIFICATION SYSTEM

Major Divisions		grf	ltr	Description	Major Divisions		grf	ltr		
Coarse Grained Soils More than 50% retained on No. 200 sieve	Gravel and Gravelly Soils	More than 50% of coarse fraction retained on No. 4 sieve	GW	Well-graded gravels or gravel sand mixtures, little or no fines	Fine Grained Soils More than 50% passes on No. 200 sieve	Silts And Clays LL, <50		ML	Inorganic silts and very fine sands, rock flour, silty or clayey fine sands or clayey silts with slight plasticity	
			GP	Poorly-graded gravels or gravel sand mixture, little or no fines				CL	Inorganic clays of low to medium plasticity, gravelly clays, sandy clays, silty clays, lean clays	
			GM	Silty gravels, gravel-sand-silt mixtures				OL	Organic silts and organic silt-clays of low plasticity	
	GC	Clayey gravels, gravel-sand-clay mixtures	MH	Inorganic silts, micaceous or diatomaceous fine or silty soils, elastic silts						
	Sand and Sandy Soils	More than 50% of coarse fraction passes on No. 4 sieve	SW	Well-graded sands or gravelly sands, little or no fines		Silts And Clays LL, <50		VH	Inorganic clays of high plasticity, fat clays	
			SP	Poorly-graded sands or gravelly sands, little or no fines				OH	Organic clays of medium to high plasticity	
			SM	Silty sands, sand-silt mixtures				PT	Peat and other highly organic soils	
			SC	Clayey sands, and-clay mixtures		Highly Organic Soils				

BOUNDARY CLASSIFICATION: Soils possessing characteristics of two groups are designated by combinations of group symbols.

PARTICLE SIZE LIMITS

	U.S. STANDARD SERIES SIEVE			CLEAR SQUARE SIEVE OPENINGS				
	200	40	10	4	3/4"	3"	12"	
Silts and Clays	Sand			Gravel		Cobbles	Boulders	
	Fine	Medium	Coarse	Fine	Coarse			

RELATIVE DENSITY

Sands and Gravels	Blows/Foot (SPT)
Very Loose	<4
Loose	4-10
Medium Dense	11-30
Dense	31-50
Very Dense	>50

CONSISTENCY CLASSIFICATION

Silts and Clays	Criteria
Very Soft	Thumb penetrates soil >1 in.
Soft	Thumb penetrates soil 1 in.
Firm	Thumb penetrates soil 1/4 in.
Stiff	Readily indented with thumbnail
Very Stiff	Thumbnail will not indent soil

HARDNESS

Bedrock
Soft
Moderately Hard
Hard
Very Hard

LABORATORY TESTS

Symbol	Test
DS	Direct Shear
DSR	Direct Shear (Remolded)
CON	Sieve Analysis
SA	Maximum Density
MAX	Resistance (R) Value
RV	Expansion Index
EI	Sand Equivalent
SE	Atterberg Limits
AL	Chemical Analysis
CHEM	Hydrometer Analysis
HY	

SOIL MOISTURE

Increasing Visual Moisture Content

↓
 Dry - Dry to touch
 Moist - Damp, but no visible free water
 wet - Visible free water

SIZE PROPORTIONS

Trace - <5%
 Few - 5 to 10%
 Some - 15 to 25%



GEOTECHNICAL BORING LOG

PROJECT NO. 1-0152
 DATE STARTED 3/23/15
 DATE FINISHED 3/23/15
 DRILLER Martini drilling
 TYPE OF DRILL RIG Hollow stem auger

PROJECT NAME Armstrong Ranch
 GROUND ELEV. _____
 GW DEPTH (FT) _____
 DRIVE WT. 140 lbs.
 DROP 30 in.

BORING DESIG. P-1
 LOGGED BY MT
 NOTE _____

DEPTH (Feet)	ELEV	SAMPLE TYPE	BLOWS	LITHOLOGY	GROUP SYMBOL	GEOTECHNICAL DESCRIPTION	MOISTURE CONT (%)	DRY (pcf) DENSITY	SAT. URATION (%)	OTHER TESTS
5		R	8	[Dotted Pattern]	SM	<p>TOPSOIL: SILTY SAND, fine grained, dark brown, dry to damp, loose.</p> <p>YOUNG ALLUVIAL FAN DEPOSITS (Qyf): SILTY SAND, fine grained, dark brown, moist, loose.</p> <p>@5 ft. dark yellow brown, trace gravel.</p>				
		R	13	[Dotted Pattern]	SM	<p>@10 ft. gravel.</p>				
<p>TOTAL DEPTH 10 FEET NO GROUNDWATER ENCOUNTERED NO CAVING OBSERVED</p>										

<p>SAMPLE TYPES:</p> <p><input checked="" type="checkbox"/> RING (DRIVE) SAMPLE</p> <p><input checked="" type="checkbox"/> SPT (SPLIT SPOON) SAMPLE</p> <p><input type="checkbox"/> BULK SAMPLE <input type="checkbox"/> TUBE SAMPLE</p>	<p><input checked="" type="checkbox"/> GROUNDWATER</p> <p><input checked="" type="checkbox"/> SEEPAGE</p> <p>J: JOINTING C: CONTACT</p> <p>B: BEDDING F: FAULT</p> <p>S: SHEAR RS: BURTURE SURFACE</p>	<p>Alta California Geotechnical, Inc.</p> <p>P.N. 1-0152 PLATE P-1</p>
--	---	--

GEOTECHNICAL BORING LOG

PROJECT NO. 1-0152
 DATE STARTED 3/23/15
 DATE FINISHED 3/23/15
 DRILLER Martini drilling
 TYPE OF DRILL RIG Hollow stem auger

PROJECT NAME Armstrong Ranch
 GROUND ELEV. _____
 GW DEPTH (FT) _____
 DRIVE WT. 140 lbs.
 DROP 30 in.

BORING DESIG. P-2
 LOGGED BY MT
 NOTE _____

DEPTH (Feet)	ELEV	SAMPLE TYPE	BLOWS	LITHOLOGY	GROUP SYMBOL	GEOTECHNICAL DESCRIPTION	MOISTURE CONT (%)	DRY (pcf) DENSITY	SAT-URATION (%)	OTHER TESTS
					SM	TOPSOIL: SILTY SAND, fine grained, dark brown, dry to damp, loose.				
					SM	YOUNG ALLUVIAL FAN DEPOSITS (Qyf): SILTY SAND, fine grained, dark yellow brown, moist, loose, trace gravel.				
5		R	7	[Pattern]		@5 ft. brown				
10		R	17	[Pattern]		@10 ft. medium dense, some gravel.				
						TOTAL DEPTH 10 FEET NO GROUNDWATER ENCOUNTERED NO CAVING OBSERVED				

SAMPLE TYPES:
 RING (DRIVE) SAMPLE
 SPT (SPLIT SPOON) SAMPLE
 BULK SAMPLE TUBE SAMPLE

GROUNDWATER
 SEEPAGE
 J: JOINTING C: CONTACT
 B: BEDDING F: FAULT
 S: SHEAR RS: RUPTURE SURFACE

Alta California Geotechnical, Inc.
 P.N. 1-0152 PLATE P-2

GEOTECHNICAL BORING LOG

PROJECT NO. 1-0152
 DATE STARTED 3/23/15
 DATE FINISHED 3/23/15
 DRILLER Martini drilling
 TYPE OF DRILL RIG Hollow stem auger

PROJECT NAME Armstrong Ranch
 GROUND ELEV. _____
 GW DEPTH (FT) _____
 DRIVE WT. 140 lbs.
 DROP 30 in.

BORING DESIG. P-3
 LOGGED BY MT
 NOTE _____

DEPTH (Feet)	ELEV	SAMPLE TYPE	BLOWS	LITHOLOGY	GROUP SYMBOL	GEOTECHNICAL DESCRIPTION	MOISTURE CONT (%)	DRY (pcf) DENSITY	SATURATION (%)	OTHER TESTS
5		R	14	[Pattern]	SM	<p>TOPSOIL: SILTY SAND, fine grained, dark brown, dry to damp, loose.</p>				
				[Pattern]	SM	<p>YOUNG ALLUVIAL FAN DEPOSITS (Qyf): SILTY SAND, fine grained, yellow brown, slightly moist.</p> <p>@5 ft. moist, few gravel, found a piece of broken rock approximately 2 inches in diameter.</p>				
10		R	33	[Pattern]	SP	<p>@10 ft. SAND, fine to medium grained, yellow brown, moist, medium dense, some gravel.</p> <p>TOTAL DEPTH 10 FEET NO GROUNDWATER ENCOUNTERED NO CAVING OBSERVED</p>				

<p>SAMPLE TYPES:</p> <p><input checked="" type="checkbox"/> RING (DRIVE) SAMPLE</p> <p><input checked="" type="checkbox"/> SPT (SPLIT SPOON) SAMPLE</p> <p><input type="checkbox"/> BULK SAMPLE <input type="checkbox"/> TUBE SAMPLE</p>	<p>▼ GROUNDWATER</p> <p>▶ SEEPAGE</p> <p>J: JOINTING C: CONTACT</p> <p>B: BEDDING F: FAULT</p> <p>S: SHEAR RS: BURSTURE SURFACE</p>	<p>Alta California Geotechnical, Inc.</p> <p>P.N. 1-0152</p> <p>PLATE P-3</p>
--	--	---

GEOTECHNICAL BORING LOG

PROJECT NO. 1-0152
 DATE STARTED 3/23/15
 DATE FINISHED 3/23/15
 DRILLER Martini drilling
 TYPE OF DRILL RIG Hollow stem auger

PROJECT NAME Armstrong Ranch
 GROUND ELEV. _____
 GW DEPTH (FT) _____
 DRIVE WT. 140 lbs.
 DROP 30 in.

BORING DESIG. P-4
 LOGGED BY MT
 NOTE _____

DEPTH (Feet)	ELEV	SAMPLE TYPE	BLOWS	LITHOLOGY	GROUP SYMBOL	GEOTECHNICAL DESCRIPTION	MOISTURE CONT (%)	DRY (pcf) DENSITY	SAT-URATION (%)	OTHER TESTS
					SM	<u>TOPSOIL</u> : SILTY SAND, fine grained, light tan, dry to damp, loose.				
					SM	<u>YOUNG ALLUVIAL FAN DEPOSITS</u> (Qyf): SILTY SAND, fine grained, light tan brown, damp to moist, some gravel.				
5		R	35	[Lithology: Silty Sand]		@5 ft. dark tan brown, moist, dense, few rocks.				
10		R	23	[Lithology: Sand]	SP	@10 ft. SAND, fine to medium grained, dark tan, moist, dense, gravel up to 3" in diameter.				
						TOTAL DEPTH 10 FEET NO GROUNDWATER ENCOUNTERED NO CAVING OBSERVED				

<p>SAMPLE TYPES:</p> <p><input checked="" type="checkbox"/> RING (DRIVE) SAMPLE</p> <p><input checked="" type="checkbox"/> SPT (SPLIT SPOON) SAMPLE</p> <p><input checked="" type="checkbox"/> BULK SAMPLE <input type="checkbox"/> TUBE SAMPLE</p>	<p>▼ GROUNDWATER</p> <p>▶ SEEPAGE</p> <p>J: JOINTING C: CONTACT</p> <p>B: BEDDING F: FAULT</p> <p>S: SHEAR RS: CRUSTURE SURFACE</p>	<p>Alta California Geotechnical, Inc.</p> <p>P.N. 1-0152</p> <p>PLATE P-4</p>
--	--	---

Project No.	1-0152
Date Excavated	March 18, 2015
Excavated by	SG
Equipment	JD 410J

TABLE I
LOG OF TEST PITS

Test Pit No.	Depth (ft.)	USCS	Description
T-1	0.0-1.0	SM	TOPSOIL: Very fine, SILTY SAND, dark brown, moist, medium dense.
	1.0-9.0	SM	YOUNG ALLUVIAL FAN DEPOSIT (Qyf): Fine grained, SILTY SAND, brown, moist, friable.
	9.0-10.0	SP	Fine to medium SAND, trace SILT, light brown, moist, friable, some cobbles, rounded.
TOTAL DEPTH 10.0 FT NO GROUNDWATER ENCOUNTERED CAVING OBSERVED 0-10 FT			

Test Pit No.	Depth (ft.)	USCS	Description
T-2	0.0-3.5	SM	TOPSOIL: Fine grained, SILTY SAND, moist, medium dense, organic smell, some pebbles, some trash and debris. @ 0-1-ft. brown @ 2-3-ft. dark gray
	3.5-6.5	SM	YOUNG ALLUVIAL FAN DEPOSIT (Qyf): Fine grained, SILTY SAND, gray brown, moist, dense, trace pebbles.
TOTAL DEPTH 6.5 FT. NO GROUNDWATER ENCOUNTERED NO CAVING OBSERVED			

Test Pit No.	Depth (ft.)	USCS	Description
T-3	0.0-4.0	SM	ARTIFICIAL FILL (afu): Fine grained, SILTY SAND, moist, moderately dense, concrete pipe, trace pebbles, organic smell. @ 0-3-ft. brown @ 3-4-ft. dark gray @ 4-ft. concrete pipe
	4.0-6.0	SM	Fine grained, SILTY SAND, light gray, moist, moderately dense, trace pebbles.
			TOTAL DEPTH 6.0 FT NO GROUNDWATER ENCOUNTERED NO CAVING OBSERVED

Test Pit No.	Depth (ft.)	USCS	Description
T-4	0.0-3.0	SM	ARTIFICIAL FILL (afu): Very fine, SILTY SAND, light yellowish brown. @ 1-ft. dry, loose @ 2-3-ft. moist, moderately loose, abundant roots and rootlets.
	3.0-6.0	SM	YOUNG ALLUVIAL FAN DEPOSIT (Qyf): Fine grained, SILTY SAND, brownish gray, moist, moderately dense, trace pebbles.
			TOTAL DEPTH 6.0 FT NO GROUNDWATER ENCOUNTERED NO CAVING OBSERVED

Test Pit No.	Depth (ft.)	USCS	Description
T-5	0.0-5.0	SM	STOCK PILE, UNDOCUMENTED ARTIFICIAL FILL (afu): Fine grained SILTY SAND, brown, dry, dense, some cobbles.
			TOTAL DEPTH 5.0 FT NO GROUNDWATER ENCOUNTERED NO CAVING OBSERVED

Test Pit No.	Depth (ft.)	USCS	Description
T-6	0.0-1.5	SM	TOPSOIL: Fine grained, SILTY SAND, light brown, moist, moderately dense, trace pebbles, abundant roots and rootlets. @ 0.5-ft. loose, abundant rootlets.
	1.5-7.0	SM	YOUNG ALLUVIAL FAN DEPOSIT (Qyf): Fine grained, SILTY SAND, brown, moist, moderately dense, trace pebbles.
			TOTAL DEPTH 7.0 FT NO GROUNDWATER ENCOUNTERED NO CAVING OBSERVED

Test Pit No.	Depth (ft.)	USCS	Description
T-7	0.0-1.5	SM	TOPSOIL: Fine grained, SILTY SAND, light brown, moist, moderately dense, trace pebbles, abundant roots and rootlets. @ 0.5-ft. loose, abundant rootlets.
	1.5-6.5	SM	YOUNG ALLUVIAL FAN DEPOSIT (Qyf): Fine grained, SILTY SAND, light brown, trace medium and coarse SAND, trace pebbles, moist, moderately dense, some roots to 3-ft.
	6.5-7.5	SP-SM	Fine grained SAND, some SILT, trace medium and coarse SAND, trace pebbles and cobbles, yellowish brown.
			TOTAL DEPTH 7.5 FT NO GROUNDWATER ENCOUNTERED NO CAVING OBSERVED

Test Pit No.	Depth (ft.)	USCS	Description
T-8	0.0-1.5	SM	TOPSOIL: Fine grained, SILTY SAND, light brown, moist, moderately dense, trace pebbles, abundant roots and rootlets. @ 0.5-ft. loose, abundant rootlets.
	1.5-6.5	SM	YOUNG ALLUVIAL FAN DEPOSIT (Qyf): Fine grained, SILTY SAND, light brown, trace medium and coarse SAND, trace pebbles, moist, moderately dense, some roots to 3-ft.
	6.5-7.5	SP-SM	Fine grained SAND, some SILT, trace medium and coarse SAND, trace pebbles and cobbles, yellowish brown.
			TOTAL DEPTH 7.5 FT NO GROUNDWATER ENCOUNTERED NO CAVING OBSERVED

Test Pit No.	Depth (ft.)	USCS	Description
T-9	0.0-1.0	SP-SM	TOPSOIL: Fine grained SAND, some SILT, some medium grained SAND, brown, moist, loose, abundant roots and rootlets, trace pebbles.
	1.0-6.0	SP-SM	YOUNG ALLUVIAL FAN DEPOSIT (Qyf): Fine grained SAND, some SILT, some medium grained SAND, trace cobbles and pebbles, moist, moderately dense.
			TOTAL DEPTH 6.0 FT NO GROUNDWATER ENCOUNTERED CAVING OBSERVED AT 1-5 FT

Test Pit No.	Depth (ft.)	USCS	Description
T-10	0.0-1.0	SM	TOPSOIL: Fine grained SILTY SAND, light gray brown, moist, loose, abundant roots and rootlets.
	1.0-2.5	SP	YOUNG ALLUVIAL FAN DEPOSIT (Qyf): Medium to coarse SAND, some gravel, trace SILT, gray brown, moist, moderately dense, fining upward, abundant pebbles, cobbles at 2.5-ft.
	2.5-6.0		Reddish brown, moist, trace cobbles, moderately dense.
			TOTAL DEPTH 6.0 FT NO GROUNDWATER ENCOUNTERED CAVING OBSERVED AT 2-6 FT

Test Pit No.	Depth (ft.)	USCS	Description
T-11	0.0-1.0	SM	TOPSOIL: Very fine grained, SILTY SAND, brown, moist, loose, abundant roots and rootlets.
	1.0-7.0	SW	YOUNG ALLUVIAL FAN DEPOSIT (Qyf): Very fine grained, SILTY SAND, yellowish brown, moist, moderately dense, massive.
			TOTAL DEPTH 7.0 FT. NO GROUNDWATER ENCOUNTERED NO CAVING OBSERVED

Test Pit No.	Depth (ft.)	USCS	Description
T-12	0.0-3.0		TOPSOIL: @ 1-ft. Mulch, dark brown. @ 2-3-ft. manure/organics, black and greenish gray.
	3.0-5.0	SM	YOUNG ALLUVIAL FAN DEPOSIT (Qyf): Fine grained, SILTY SAND, brown, moist, moderately dense, trace coarse grained SAND.
	5.0-6.0	SP	Coarse SAND, some very coarse SAND fine gravel, trace pebbles and cobbles, trace SILT, yellowish brown, moist, moderately dense.
	6.0-7.0	SM	Fine grained, SILTY SAND, reddish brown, moist, moderately dense, trace cobbles and pebbles.
			TOTAL DEPTH 7.0 FT. NO GROUNDWATER ENCOUNTERED NO CAVING OBSERVED

Test Pit No.	Depth (ft.)	USCS	Description
T-13	0.0-2.0	SM	TOPSOIL: Fine grained, SILTY SAND, dark brown, moist, loose to moderately dense, organic rich, abundant roots and rootlets, trace pebbles.
	2.0-7.0	SM	YOUNG ALLUVIAL FAN DEPOSIT (Qyf): Fine grained, SILTY SAND, brown, moist, moderately dense, trace pebbles, massive.
			TOTAL DEPTH 7.0 FT. NO GROUNDWATER ENCOUNTERED NO CAVING OBSERVED

Test Pit No.	Depth (ft.)	USCS	Description
T-14	0.0-1.0	SM	TOPSOIL: Fine grained, SILTY SAND with some organics, brown, moist, moderately loose, trace pebbles, some rootlets.
	1.0-5.5	SM	YOUNG ALLUVIAL FAN DEPOSIT (Qyf): Fine grained SILTY SAND, brown, moist, moderately dense, trace pebbles, massive.
	5.5-7.5	SP	YOUNG ALLUVIAL FAN DEPOSIT (Qyf): Medium to coarse grained SAND, some very coarse, some gravel, trace pebbles and cobbles, yellowish brown, moist, fining upward, cobbles at 7.5-ft.
			TOTAL DEPTH 7.5 FT. NO GROUNDWATER ENCOUNTERED NO CAVING OBSERVED

Test Pit No.	Depth (ft.)	USCS	Description
T-15	0.0-1.0	SM	TOPSOIL: Very fine grained SILTY SAND, brown, moist, moderately loose, trace rootlets, some mulch in upper 0.5-ft.
	1.0-8.0	ML	YOUNG ALLUVIAL FAN DEPOSIT (Qyf): SANDY SILT, with very fine grained SAND, moist, low plasticity, medium stiff, trace pebbles, massive.
			TOTAL DEPTH 8.0 FT. NO GROUNDWATER ENCOUNTERED NO CAVING OBSERVED

Test Pit No.	Depth (ft.)	USCS	Description
T-16	0.0-1.0	SM	TOPSOIL: Very fine grained SILTY SAND, brown, moist, moderately loose, trace rootlets, no mulch.
	1.0-7.0	SM	YOUNG ALLUVIAL FAN DEPOSIT (Qyf): Very fine grained SILTY SAND, brown with some gray mottling, moist, moderately dense, massive, trace pebbles.
	7.0-9.0	SM	Fine grained SILTY SAND, some medium grained, yellowish brown, trace gravel and pebbles.
			TOTAL DEPTH 9.0 FT. NO GROUNDWATER ENCOUNTERED NO CAVING OBSERVED

Test Pit No.	Depth (ft.)	USCS	Description
T-17	0.0-1.0	SM	TOPSOIL: Very fine grained SILTY SAND, brown, moist, moderately loose, trace rootlets, some mulch in upper 0.5-ft.
	1.0-7.0	SM	YOUNG ALLUVIAL FAN DEPOSIT (Qyf): Very fine grained SILTY SAND, brown with some gray mottling, moist, moderately dense, massive, trace pebbles.
	7.0-8.0	SM	Fine grained SILTY SAND, yellowish brown, trace gravel and pebbles.
			TOTAL DEPTH 8.0 FT. NO GROUNDWATER ENCOUNTERED NO CAVING OBSERVED

Test Pit No.	Depth (ft.)	USCS	Description
T-18	0.0-1.0	SM	TOPSOIL: Very fine grained SILTY SAND, brown, moist, moderately loose, trace rootlets, some mulch in upper 0.5-ft.
	1.0-6.5	SM	YOUNG ALLUVIAL FAN DEPOSIT (Qyf): Very fine grained SILTY SAND, brown with some gray mottling, moist, moderately dense, massive, trace pebbles.
	6.5-7.0	SM	Fine grained SILTY SAND, some medium grained, yellowish brown, trace gravel and pebbles.
			TOTAL DEPTH 7.0 FT. NO GROUNDWATER ENCOUNTERED NO CAVING OBSERVED

Test Pit No.	Depth (ft.)	USCS	Description
T-19	0.0-1.0	SM	TOPSOIL: Very fine grained SILTY SAND, brown, moist, moderately loose, trace rootlets.
	1.0-8.0	SM	YOUNG ALLUVIAL FAN DEPOSIT (Qyf): Very fine grained SILTY SAND, brown with some gray mottling, moist, moderately dense, massive, trace pebbles, and cobbles.
			TOTAL DEPTH 8.0 FT. NO GROUNDWATER ENCOUNTERED NO CAVING OBSERVED

Test Pit No.	Depth (ft.)	USCS	Description
T-20	0.0-2.0	SM	TOPSOIL: Very fine grained SILTY SAND, brown, moist, moderately loose, trace rootlets, some mulch in upper 0.5-ft. @ 1.5-ft. PVC water line.
	2.0-7.5	SM	YOUNG ALLUVIAL FAN DEPOSIT (Qyf): Very fine grained SILTY SAND, brown with some gray mottling, moist, moderately dense, massive, trace pebbles.
<p>TOTAL DEPTH 7.5 FT. NO GROUNDWATER ENCOUNTERED NO CAVING OBSERVED</p>			

Test Pit No.	Depth (ft.)	USCS	Description
T-21	0.0-1.0	SM	TOPSOIL: Very fine grained SILTY SAND, brown, moist, moderately loose, 2-inch of manure at surface, some rootlets.
	1.0-8.5	SM	YOUNG ALLUVIAL FAN DEPOSIT (Qyf): Fine grained SILTY SAND, trace pebbles, brown, moist, moderately dense, sand lenses with fine grained SAND, gravel, and pebbles.
	8.5-10.5	SP	Medium grained SAND, trace SILT, some gravel, some pebbles, trace cobbles, yellowish brown.
<p>TOTAL DEPTH 10.5 FT. NO GROUNDWATER ENCOUNTERED NO CAVING OBSERVED</p>			

Test Pit No.	Depth (ft.)	USCS	Description
T-22	0.0-1.0	SM	TOPSOIL: Very fine grained SILTY SAND, brown, moist, moderately loose, 2-inch of manure at surface, some rootlets.
	1.0-8.0	SM	YOUNG ALLUVIAL FAN DEPOSIT (Qyf): Fine grained SILTY SAND, trace pebbles, brown, moist, moderately dense.
			TOTAL DEPTH 8.0 FT. NO GROUNDWATER ENCOUNTERED NO CAVING OBSERVED

Test Pit No.	Depth (ft.)	USCS	Description
T-23	0.0-1.0	SM	TOPSOIL: Very fine grained SILTY SAND, brown, moist, moderately loose, 2-inch of manure at surface, some rootlets.
	1.0-7.0	SM	YOUNG ALLUVIAL FAN DEPOSIT (Qyf): Fine grained SILTY SAND, trace pebbles, brown, moist, moderately dense, sand lenses with fine grained sand, gravel, and pebbles.
			TOTAL DEPTH 7.0 FT. NO GROUNDWATER ENCOUNTERED NO CAVING OBSERVED

Test Pit No.	Depth (ft.)	USCS	Description
T-24	0.0-1.0	SM	TOPSOIL: Very fine grained SILTY SAND, brown, moist, moderately loose, trace rootlets, some mulch in upper 0.5-ft.
	1.0-5.0	SM	YOUNG ALLUVIAL FAN DEPOSIT (Qyf): Very fine grained SILTY SAND, brown, moist, moderately dense, trace pebbles, massive.
	5.0-9.0	SP	Fine to medium grained SAND, trace SILT, some gravel and cobbles, light brown.
			TOTAL DEPTH 9.0 NO GROUNDWATER ENCOUNTERED NO CAVING OBSERVED

Test Pit No.	Depth (ft.)	USCS	Description
T-25	0.0-2.5	SM	TOPSOIL: Very fine grained SILTY SAND, trace pebbles, brown, moist. @ 1-ft. loose @ 1-2-ft. moderately loose, trace pebbles, some reddish brown organic material.
	2.5-3.5	SM	YOUNG ALLUVIAL FAN DEPOSIT (Qyf): Very fine grained SILTY SAND, trace pebbles, brown, moist, moderately dense.
	3.5-7.0	SP	Fine to medium grained SAND, trace SILT, some coarse SAND, gravel, pebbles and cobbles.
			TOTAL DEPTH 7.0 FT. NO GROUNDWATER ENCOUNTERED POTENTIAL CAVING OBSERVED

Test Pit No.	Depth (ft.)	USCS	Description
T-26	0.0-1.0	SM	TOPSOIL: Very fine grained SILTY SAND, brown, moist, moderately loose, 2-inch of manure at surface, some rootlets.
	1.0-8.0	SM	YOUNG ALLUVIAL FAN DEPOSIT (Qyf): Fine grained SILTY SAND, trace gravel and pebbles, brown, moist, moderately dense, massive.
			TOTAL DEPTH 8.0 FT. NO GROUNDWATER ENCOUNTERED NO CAVING OBSERVED

Test Pit No.	Depth (ft.)	USCS	Description
T-27	0.0-1.0	SM	TOPSOIL: Very fine grained SILTY SAND, brown, moist, moderately loose, some rootlets, trace cobbles, faint organic smell. @ 4- inch of manure at surface
	1.0-8.5	SM	YOUNG ALLUVIAL FAN DEPOSIT (Qyf): Fine grained SILTY SAND, trace gravel and pebbles, brown, moist, moderately dense, massive.
			TOTAL DEPTH 8.5 FT. NO GROUNDWATER ENCOUNTERED NO CAVING OBSERVED

Test Pit No.	Depth (ft.)	USCS	Description
T-28	0.0-1.5	SM	TOPSOIL: Gravel with fine grained SILTY SAND, some medium grained SAND, tan colored, moist, moderately loose. @ 2-inches manure on surface, abundant rootlets in top 0.5-ft.
	1.5-7.0	SM	YOUNG ALLUVIAL FAN DEPOSIT (Qyf): Fine grained SILTY SAND, trace pebbles, brown, moist, moderately dense.
			TOTAL DEPTH 7.0 FT. NO GROUNDWATER ENCOUNTERED NO CAVING OBSERVED

Test Pit No.	Depth (ft.)	USCS	Description
T-29	0.0-1.0	SM	TOPSOIL: Very fine grained SILTY SAND, brown, moist, moderately loose, 2-inches of manure at surface, some rootlets.
	1.0-3.5	SM	YOUNG ALLUVIAL FAN DEPOSIT (Qyf): Fine grained SILTY SAND, trace gravel and pebbles, brown, moist, moderately dense, massive.
	3.5-9.0	SP-SM	Fine to medium grained SAND, some SILT, some gravel, coarse SAND, and cobbles, yellowish brown.
			TOTAL DEPTH 9.0 FT. NO GROUNDWATER ENCOUNTERED NO CAVING OBSERVED CAVING POTENTIAL BELOW 3.5 FT.

Test Pit No.	Depth (ft.)	USCS	Description
T-30	0.0-1.0	SM	TOPSOIL: Very fine grained SILTY SAND, brown, moist, moderately loose, 2-inches of manure at surface, some rootlets.
	1.0-8.5	SM	YOUNG ALLUVIAL FAN DEPOSIT (Q_{vf}): Fine grained SILTY SAND, trace pebbles, brown, moist, moderately dense, sand lenses with fine grained sand, gravel, and pebbles.

TOTAL DEPTH 8.5 FT.
NO GROUNDWATER ENCOUNTERED
NO CAVING OBSERVED

TABLE B

Date	Test Location	Depth (ft)	Moisture (%)	Wet Density (pcf)	Dry Density (pcf)
3/18/2015	TP-2	-2	15.0	115.4	100.3
3/18/2015	TP-2	-4	5.5	122.7	116.3
3/18/2015	TP-3	-3	18.1	119.6	101.3
3/18/2015	TP-4	-2	5.9	107.3	101.3
3/18/2015	TP-4	-4	5.5	102.6	97.2
3/18/2015	TP-8	-2	12.1	109.2	97.4
3/18/2015	TP-8	-4	7.2	103.1	96.2
3/19/2015	TP-15	-3	16.0	108.2	93.3
3/19/2015	TP-15	-5	12.6	114.8	102.0
3/19/2015	TP-16	-2	9.5	106.2	97.0
3/19/2015	TP-16	-4	10.7	101.2	91.4
3/19/2015	TP-17	-2	11.2	106.1	95.4
3/19/2015	TP-17	-4	11.2	107.6	96.8
3/19/2015	TP-18	-3	12.4	104.7	93.1
3/19/2015	TP-19	-3	8.5	113.9	105.0
3/19/2015	TP-21	-3	8.4	117.5	108.4
3/19/2015	TP-22	-3.5	5.9	116.5	110.0
3/19/2015	TP-23	-3	8.7	114.3	105.2
3/19/2015	TP-24	-3	9.7	112.2	102.3

APPENDIX B-1

Previous Subsurface Investigation

Moisture (%)	Dry Density (pcf)	Penetration Resistance (Blows/6 inch)	Sample Type	Depth (Feet)	Lithology	BORING LOG NO.: GK-1	
						Description of Subsurface Materials: Classification, (USCS) color, mixture, consistency, etc.	
					SM	Surface: Silty Sand (SM), Brown, dry, loose.	
5.7	106.7	6/7/10	R-1	5	SP	Sand (SP): Light yellowish brown, Slightly moist, medium dense, poorly graded	
1.5	120.0	9/15/15	R-2	10	GP	@10' Sandy Gravel (GP): Light yellowish brown, dry, gravel to 2.5" diameter	
7.6	107.3	5/6/10	R-3	15	SP-SM	@15' Silty Sand (SP-SM): Dark yellowish brown, slightly moist, medium dense poorly graded	
26.2	97.5	5/7/11	R-4	20	SC	@20' Clayey Sand (SC): Olive brown, wet, very stiff.	
						Total Depth = 21' No Groundwater Backfilled with cuttings	

 <p>Geotechnical & Environmental Engineers</p>	Sample Types: <input type="checkbox"/> Bulk Sample <input type="checkbox"/> Rock Core <input type="checkbox"/> Ring Sample <input type="checkbox"/> Standard Split Spoon <input type="checkbox"/> Tube Sample	Location: _____ Date Drilled: <u>9/14/04</u> Equipment Used: <u>CME-75</u> Ring Type: <u>2.5"</u> Ground Elevation: _____ Notes: _____	Logged by: <u>SST</u>
	Project Name: <u>Hillcrest De Boer</u> Project No.: <u>1957</u>		

Moisture (%)	Dry Density (pcf)	Penetration Resistance (Blows/6 inch)	Sample Type	Depth (Feet)	Lithology	BORING LOG NO.: GK-2		Elevation (Feet)
						Description of Subsurface Materials: Classification, (USCS) color, mixture, consistency, etc.		
			B			Surface: Silty Sand; light brown, dry, loose.		
14.4	111.7	3/5/6	R-1	5	SM	@5' Silty Sand with Clay (SM/SC): Light brown, moist, medium stiff, minor pinhole porosity		
11.1	116.6	6/8/18	R-2	10	SM	@10' Silty Sand (SM): Yellowish brown, moist, dense, mottled		
21.4	104.0	6/10/12	R-3	15	ML	@15' Silt (ML): Mottled yellowish brown, very moist, minor pinhole porosity		
24.5	101.6	9/15/21	R-4	20		@20' Silt (ML): Mottled yellowish brown, very moist, minor pinhole porosity		
				25		Total Depth = 21' No Groundwater Backfilled with cuttings		
				30				
				35				

GeoKinetics

Geotechnical & Environmental Engineers

Project Name: Hillcrest De Boer

Project No.: 1957

Sample Types:

- B Bulk Sample
- C Rock Core
- R Ring Sample
- S Standard Split Spoon
- T Tube Sample

Location: _____ Logged by: SST

Date Drilled: 9/14/04 Equipment Used: CME-75 Ring Type: 2.5"

Ground Elevation: _____ Notes: _____

Moisture (%)	Dry Density (pcf)	Penetration Resistance (Blows/6 inch)	Sample Type	Depth (Feet)	Lithology	BORING LOG NO.: GK-3		Elevation (Feet)
						Description of Subsurface Materials: Classification, (USCS) color, mixture, consistency, etc.		
					SM	<u>Surface:</u> Silty Sand, brown, dry, loose.		
15.4	113.1	3/5/6	R-1	5	CL	Sandy Clay (CL) Brown, moist, medium stiff, minor pinhole porosity & caliche stringers.		
11.1	119.8	6/8/18	R-2	10	SC	@10' Clayey Sand (SC): Dark yellowish brown, moist, dense, mottled, minor pinhole porosity.		
11.9	107.4	6/10/12	R-3	15	ML	@15' Sandy Silt (ML): Dark yellowish brown, moist, dense pinhole porosity.		
12.7	113.0	9/15/21	R-4	20	ML	@20' Sandy Silt (ML): Dark yellowish brown, moist, very stiff pinhole porosity.		
21.3	105.5	6/8/18	R-5	25	CL	@25' Silty Clay (CL): Dark yellowish brown, mottled, very moist, very stiff.		
5.2	124.6	6/10/12	R-6	30	SM/SC	@30' Silty Sand with Clay (SM/SC): Dark yellowish brown, slightly moist, very dense pinhole porosity.		
2.2	126.6	9/15/21	R-7	35	GP	@35' Sandy Gravel (GP): Yellowish brown, dry, very dense, gravels to 1" diameter.		

GeoKinetics

Geotechnical & Environmental Engineers

Project Name: Hillcrest De Boer

Project No.: 1957

Sample Types:

- B Bulk Sample
- C Rock Core
- R Ring Sample
- S Standard Split Spoon
- T Tube Sample

Location: _____ Logged by: SST

Date Drilled: 9/14/04 Equipment Used: CME-75 Ring Type: 2.5"

Ground Elevation: _____ Notes: _____

Moisture (%)	Dry Density (pcf)	Penetration Resistance (Blows/6 inch)	Sample Type	Depth (Feet)	Lithology	BORING LOG NO.: GK-3 Continued	
						Description of Subsurface Materials: Classification, (USCS) color, mixture, consistency, etc.	
2.1	130.1	3/5/6	R-8	40	SP	@40' Gravelly Sand (SP): Yellowish brown, dry, very dense, poorly graded, gravels to 1" diameter.	
8.0	119.3	6/8/18	R-9	45	SP	@45' <u>Tip</u> : Gravelly Sand (SP): Yellowish brown, moist, very dense, gravels to 1" diameter. <u>Top</u> : Silty Sand (SM), fine sand, dark yellowish brown, moist, very dense.	
3.0	121.8	6/10/12	R-10	50	SP/GP	@50' Sandy Gravel/Gravelly Sand (SP/GP): Dark yellowish brown, dry, very dense.	
						Total Depth = 51' No Groundwater Backfilled with cuttings	

GeoKinetics

Geotechnical & Environmental Engineers

Project Name: Hillcrest De Boer

Project No.: 1957

Sample Types:

- Bulk Sample
- Rock Core
- Ring Sample
- Standard Split Spoon
- Tube Sample

Location: _____ Logged by: SST

Date Drilled: 9/14/04 Equipment Used: CME-75 Ring Type: 2.5"

Ground Elevation: _____ Notes: _____

Moisture (%)	Dry Density (pcf)	Penetration Resistance (Blows/6 inch)	Sample Type	Depth (Feet)	Lithology	BORING LOG NO.: GK-4		Elevation (Feet)
						Description of Subsurface Materials: Classification, (USCS) color, mixture, consistency, etc.		
					SM	Surface: @1' Silty Sand (SM): Brown, damp, loose		
5.0	110.3	4/5/8	R-1	5	SM	@5' Silty Sand (SM): Dark yellowish brown, slightly moist, medium dense, massive		
2.4	104.4	6/9/12	R-2	10	SW	@10' Sand (SW): Grayish brown, dry, very dense		
1.9	122.4	11/12/20	R-3	15	SW	@15' Sand (SW): Grayish brown, dry, very dense		
10.0	96.6	10/10/15	R-3	20	ML	@20' Very Fine Sandy Silt (ML) Dark yellowish brown, moist, very stiff		
						Total Depth = 21' No Groundwater Backfilled with cuttings		
				25				
				30				
				35				

GeoKinetics

Geotechnical & Environmental Engineers

Project Name: Hillcrest De Boer

Project No.: 1957

Sample Types:

- Bulk Sample
- Rock Core
- Ring Sample
- Standard Split Spoon
- Tube Sample

Location: _____ Logged by: SST

Date Drilled: 9/14/04 Equipment Used: CME-75 Ring Type: 2.5"

Ground Elevation: _____ Notes: _____

Moisture (%)	Dry Density (pcf)	Penetration Resistance (Blows/6 inch)	Sample Type	Depth (Feet)	Lithology	BORING LOG NO.: GK-5		Elevation (Feet)
						Description of Subsurface Materials: Classification, (USCS) color, mixture, consistency, etc.		
					SM	<u>Surface: Top Soil:</u> @1' Silty Sand (SM): Dark brown, damp, loose		
9.3	106.8	4/5/8	R-1	5	SM	@5' Silty Sand (SM): Dark grayish brown, moist, medium dense, massive		
9.5	108.0	6/9/12	R-2	10	SM	@10' Silty Sand (SM): Dark grayish brown, moist, medium dense, massive		
4.3	119.2	11/12/20	R-3	15	SM	@15' Silty Sand (SM): Dark grayish brown, slightly moist, medium dense, massive with gravel		
16.1	115.8	10/10/15	R-3	20	SM	@20' Silty Sand (SM) Mottled olive brown and dark brownish gray, very moist, very dense		
						Total Depth = 21' No Groundwater Backfilled with cuttings		
				25				
				30				
				35				

GeoKinetics

Geotechnical & Environmental Engineers

Project Name: Hillcrest De Boer

Project No.: 1957

Sample Types:

- B Bulk Sample
- C Rock Core
- R Ring Sample
- S Standard Split Spoon
- T Tube Sample

Location: _____ Logged by: SST

Date Drilled: 9/14/04 Equipment Used: CME-75 Ring Type: 2.5"

Ground Elevation: _____ Notes: _____

Moisture (%)	Dry Density (pcf)	Penetration Resistance (Blows/6 inch)	Sample Type	Depth (Feet)	Lithology	BORING LOG NO.: GK-6		Elevation (Feet)
						Description of Subsurface Materials: Classification, (USCS) color, mixture, consistency, etc.		
					SM	Surface: Top Soil Silty Sand (SM) Brown, dry, loose.		
6.3	107.5	5/5/7	R-1	5	SP	@5' Silty Fine Sand (SP/SM): Brown, moist, medium dense, poorly graded.		
3.1	120.8	7/9/15	R-2	10	SP	@10' Gravely Sand / Sandy Gravel (SP/GP): Yellowish brown, dry, dense.		
12.6	116.6	9/11/17	R-3	15	SC	@15' Clayey Sand (SC): Dark yellowish brown, moist, dense, minor pinhole porosity.		
6.1	116.7	12/13/18	R-4	20	SM	@20' Silty Sand (SM): Dark yellowish brown, slightly moist, dense, minor pinhole porosity.		
						Total Depth = 21' No Groundwater Backfilled with cuttings		



Project Name: Hillcrest De Boer
Project No.: 1957

- Sample Types:
- B Bulk Sample
 - C Rock Core
 - R Ring Sample
 - S Standard Split Spoon
 - T Tube Sample

Location: _____ Logged by: SST
Date Drilled: 9/14/04 Equipment Used: CME-75 Ring Type: 2.5"
Ground Elevation: _____ Notes: _____

Moisture (%)	Dry Density (pcf)	Penetration Resistance (Blows/6 inch)	Sample Type	Depth (Feet)	Lithology	BORING LOG NO.: GK-7	
						Description of Subsurface Materials: Classification, (USCS) color, mixture, consistency, etc.	
					SM	Surface: Silty Sand (SM), light brown, damp, loose.	
7.8	106.2	3/3/6	R-1	5	SM	@5' Silty Sand (SM): Dark brown, slightly moist, loose.	
20.7	107.1	4/4/4	R-2	10	ML	@10' Sandy Silt (ML): Yellowish brown, very moist, medium soft	
6.4	111.9	12/14/17	R-3	15	SW	@15' Gravelly Sand (SW): Dark yellowish brown, slightly moist, medium dense, gravels to 2" diameter	
5.6	128.1	50/43/50	R-4	20	SP	@20' Sand (SP): Light brown, slightly moist, very dense.	
				25		Total Depth = 21' No Groundwater Backfilled with cuttings	
				30			
				35			

 <p>Geotechnical & Environmental Engineers</p>	Sample Types: <input type="checkbox"/> Bulk Sample <input type="checkbox"/> Rock Core <input type="checkbox"/> Ring Sample <input type="checkbox"/> Standard Split Spoon <input type="checkbox"/> Tube Sample	Location: _____ Date Drilled: <u>9/14/04</u> Equipment Used: <u>CME-75</u> Ring Type: <u>2.5"</u> Ground Elevation: _____ Notes: _____	Logged by: <u>SST</u>
	Project Name: <u>Hillcrest De Boer</u> Project No.: <u>1957</u>		

Moisture (%)	Dry Density (pcf)	Penetration Resistance (Blows/6 inch)	Sample Type	Depth (Feet)	Lithology	BORING LOG NO.: GK-8	
						Description of Subsurface Materials: Classification, (USCS) color, mixture, consistency, etc.	
					SM	Surface: Silty Sand (SM), brown, damp, loose.	
3.4	102.3	3/3/6	R-1	5	SP	@5' Sand (SP): Yellowish brown, dry, loose.	
12.4	115.8	4/4/4	R-2	10	SC	@10' Clayey Sand (SC): Dark yellowish brown, moist, loose.	
8.8	117.4	12/14/17	R-3	15	SM	@15' Silty Sand (SM): Dark yellowish brown, moist, medium dense, occasional gravels to 2.5" diameter, some silt.	
3.4	118.0	50/43/50	R-4	20	SP	@20' Sand (SP): Dark yellowish brown, damp moist, very dense, massive.	
						Total Depth = 21' No Groundwater Backfilled with cuttings	

GeoKinetics Geotechnical & Environmental Engineers	Sample Types: <input type="checkbox"/> Bulk Sample <input type="checkbox"/> Rock Core <input type="checkbox"/> Ring Sample <input type="checkbox"/> Standard Split Spoon <input type="checkbox"/> Tube Sample	Location: _____ Date Drilled: <u>9/14/04</u> Equipment Used: <u>CME-75</u> Ring Type: <u>2.5"</u> Ground Elevation: _____ Notes: _____	Logged by: <u>SST</u>
	Project Name: <u>Hillcrest De Boer</u> Project No.: <u>1957</u>		

Moisture (%)	Dry Density (pcf)	Penetration Resistance (Blows/6 inch)	Sample Type	Depth (Feet)	Lithology	BORING LOG NO.: GK-9	
						Description of Subsurface Materials: Classification, (USCS) color, mixture, consistency, etc.	
					SM	Surface: Manure @1' Silty Sand (SM): Yellowish brown, moist, loose.	
3.0	113.3	3/3/6	R-1	5	SP	@5' Sand (SP): Yellowish brown, dry, loose.	
3.7	110.6	4/4/4	R-2	10	SP	@10' Sandy (SP): Dark yellowish brown, dry, loose.	
3.7	105.8	12/14/17	R-3	15	SM-SP	@15' Silty Sand with Gravel (SM-SP): Dark yellowish brown, dry, medium dense, occasional gravels to 2.5" diameter.	
28.6	94.3	50/43/50	R-4	20	CL	@20' Sandy Clay (CL): Dark yellowish brown, very moist, very dense, massive.	
				25		Total Depth = 21' No Groundwater Backfilled with cuttings	
				30			
				35			

GeoKinetics Geotechnical & Environmental Engineers	Sample Types: <input type="checkbox"/> Bulk Sample <input type="checkbox"/> Rock Core <input type="checkbox"/> Ring Sample <input type="checkbox"/> Standard Split Spoon <input type="checkbox"/> Tube Sample	Location: _____ Date Drilled: <u>9/14/04</u> Equipment Used: <u>CME-75</u> Ring Type: <u>2.5"</u> Ground Elevation: _____ Notes: _____	Logged by: <u>SST</u>
	Project Name: <u>Hillcrest De Boer</u> Project No.: <u>1957</u>		

Moisture (%)	Dry Density (pcf)	Penetration Resistance (Blows/6 inch)	Sample Type	Depth (Feet)	Lithology	BORING LOG NO.: GK-10		Elevation (Feet)
						Description of Subsurface Materials: Classification, (USCS) color, mixture, consistency, etc.		
						Surface: @1' Silty fine sand, medium brown, moist, loose.		
2.9	121.0	7/6/6	R-1	5	SM	@5' Silty Sand (SM): Yellowish brown, dry, medium dense, occasional gravels to 2" diameter		
10.5	119.6	4/14/21	R-2	10	SM	@10' Silty Gravelly Sand (SM): Yellowish brown, moist, very dense, gravels to 1/2" diameter, F _o patches.		
3.6	131.6	3/15/21	R-3	15	SW	@15' Gravelly Sand (SW): Brown, dry, very dense gravels to 2.5" diameter.		
18.5	103.4	6/12/12	R-4	20	ML	@20' Tip: Silt (ML): Dark yellowish brown, moist, stiff. Top: Silty Sand (SM) Dark yellowish brown, moist, dense.		
7.6	104.6	5/12/27	R-5	25	SM	@25' Silty Fine Sand (SM): Olive brown, slightly moist, very dense.		
19.8	109.3	7/15/24	R-6	30	ML	@30' Fine Sandy Silt (ML): Dark yellowish brown, very moist, very stiff to hard.		
19.0	109.7	8/15/20	R-7	35	ML	@35' Silt (ML): Dark yellowish brown, very moist, very stiff.		



Geotechnical & Environmental Engineers

Project Name: Hillcrest De Boer

Project No.: 1957

Sample Types:

- B Bulk Sample
- C Rock Core
- R Ring Sample
- S Standard Split Spoon
- T Tube Sample

Location: _____ Logged by: SST

Date Drilled: 9/14/04 Equipment Used: CME-75 Ring Type: 2.5"

Ground Elevation: _____ Notes: _____

Moisture (%)	Dry Density (pcf)	Penetration Resistance (Blows/6 inch)	Sample Type	Depth (Feet)	Lithology	BORING LOG NO.: GK-10 Cont.	
						Description of Subsurface Materials: Classification, (USCS) color, mixture, consistency, etc.	
19.2	111.1	9/17/23	R-8	40	ML	@40' Silt (ML): Dark yellowish brown, very moist, very stiff.	
8.0	119.3	12/16/26	R-9	45	SM	@45' Silty Fine Sand (SM): Dark yellowish brown, slightly moist, very dense.	
3.0	121.8	8/11/14	R-10	50	ML	@50' Sandy Silt (ML): Dark yellowish brown, dry, very stiff.	
						Total Depth = 51' No Groundwater Backfilled with cuttings	

GeoKinetics

Geotechnical &
Environmental Engineers

Project Name: Hillcrest De Boer

Project No.: 1957

Sample Types:

- B Bulk Sample
- C Rock Core
- R Ring Sample
- S Standard Split Spoon
- T Tube Sample

Location: _____ Logged by: SST

Date Drilled: 9/14/04 Equipment Used: CME-75 Ring Type: 2.5"

Ground Elevation: _____ Notes: _____

Moisture (%)	Dry Density (pcf)	Penetration Resistance (Blows/6 inch)	Sample Type	Depth (Feet)	Lithology	BORING LOG NO.: GK-11		Elevation (Feet)
						Description of Subsurface Materials: Classification, (USCS) color, mixture, consistency, etc.		
					SP	Surface: @1' Silty Sand (SP): Dark brown, moist, loose.		
8.1	103.7	4/4/6	R-1	5	SM	@5' Silty Fine Sand (SM): Strong brown, moist, medium dense.		
14.0	117.6	2/5/8	R-2	10	SM-ML	@10' Silty Sand / Sandy Silt (SM/ML): Dark yellowish brown, moist, medium dense, massive.		
5.0	126.5	5/7/11	R-3	15	SM	@15' Gravelly Silty Sand (SM): Dark yellowish brown, slightly moist, dense, gravel to 1" diameter.		
3.6	121.8	19/20/19	R-4	20	SM	@20' Top: Gravelly Silty Sand (SM): Dark yellowish brown, dry, dense, gravel to 1" diameter. Tip: Sandy Silt (ML) Moist, yellowish brown, very stiff.		
				25		Total Depth = 21' No Groundwater Backfilled with cuttings		
				30				
				35				

GeoKinetics

Geotechnical & Environmental Engineers

Project Name: Hillcrest De Boer

Project No.: 1957

Sample Types:

- Bulk Sample
- Rock Core
- Ring Sample
- Standard Split Spoon
- Tube Sample

Location: _____ Logged by: SST

Date Drilled: 9/13/04 Equipment Used: CME-75 Ring Type: 2.5"

Ground Elevation: _____ Notes: _____

Moisture (%)	Dry Density (pcf)	Penetration Resistance (Blows/6 inch)	Sample Type	Depth (Feet)	Lithology	BORING LOG NO.: GK-12		Elevation (Feet)
						Description of Subsurface Materials: Classification, (USCS) color, mixture, consistency, etc.		
			B		SM	Surface: Grass @1' Silty Sand (SM): Brown, damp, loose, roots.		
8.5	115.4	3/7/8	R-1	5	SP	@5' Silty Sand (SM): Brown, moist, medium dense.		
2.3	118.0	6/10/17	R-2	10	SW	@10' Sand (SW): Brown, to light brown, dry, medium dense.		
2.7	121.2	6/9/21	R-3	15	SM	@15' Top: Silty Sand (SM): Olive brown, dry, dense. Tip: Gravelly Sand (SW): Light yellowish brown, dry, dense.		
19.6	110.4	6/10/19	R-4	20	ML	@20' Silt (ML) Dark yellowish brown, very moist, stiff.		
				25		Total Depth = 21' No Groundwater Backfilled with cuttings		
				30				
				35				

GeoKinetics

Geotechnical & Environmental Engineers

Project Name: Hillcrest De Boer

Project No.: 1957

Sample Types:

- B Bulk Sample
- C Rock Core
- R Ring Sample
- S Standard Spill Spoon
- T Tube Sample

Location: _____ Logged by: SST

Date Drilled: 9/13/04 Equipment Used: CME-75 Ring Type: 2.5"

Ground Elevation: _____ Notes: _____

Geologic Attitudes	Description	Geologic Unit
	0" - 8" Silty Sand (SM); Light yellowish brown, dry, very loose, Organics.	
	8" - 14" Silty Sand (SM); Medium red brown, moist, loose, organics	
	14" - 66" Silty Sand (SM); Medium red brown, moist, dense, roots.	
	66" - 72" Silty Sand (SM); Medium Yellowish brown, moist, moderately dense.	

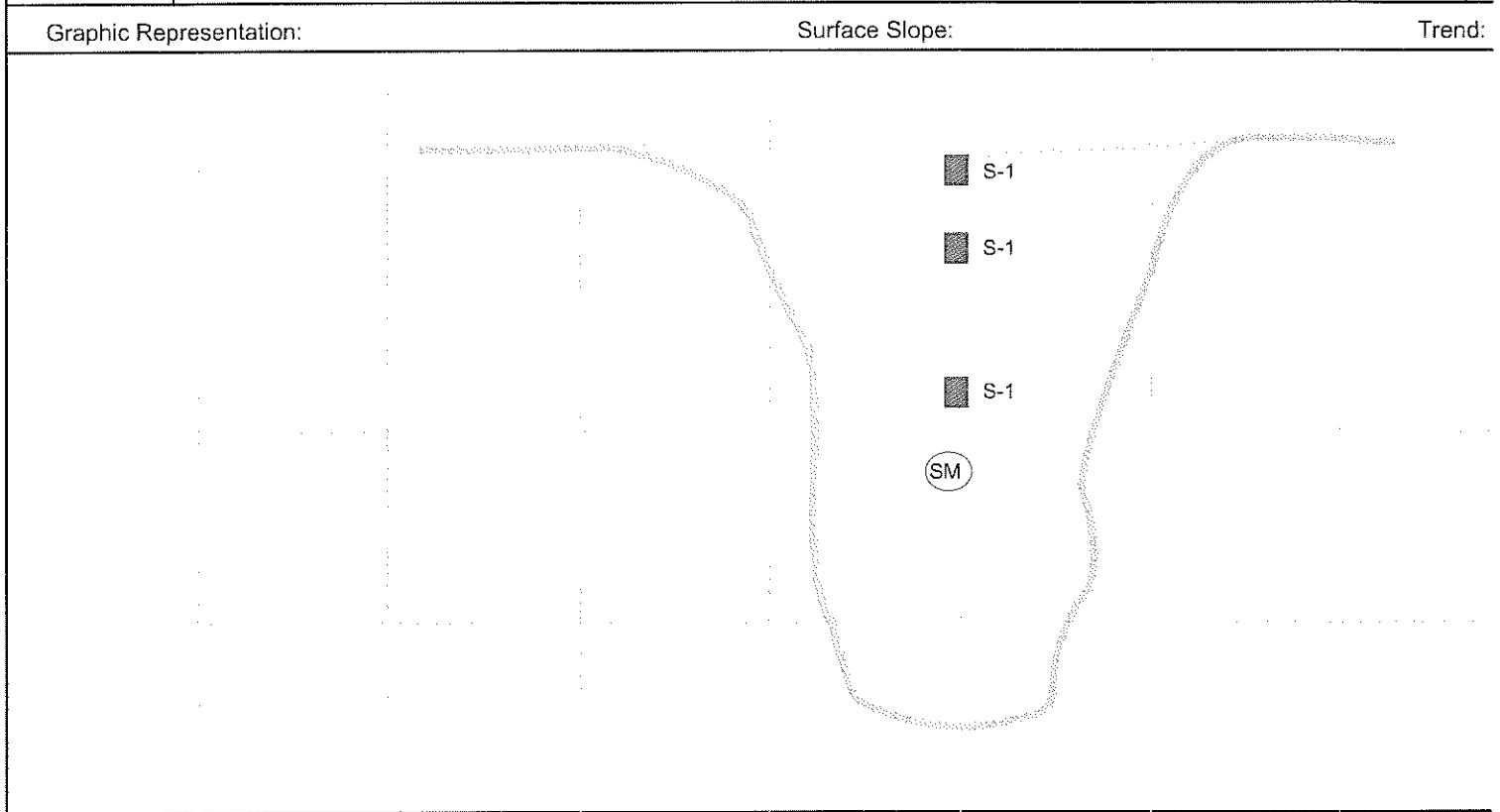

Geologic Attitudes	Description	Geologic Unit
	<p>0" - 9" Silty Sand (SM); Light yellowish brown, dry, very loose, Organics.</p> <p>9" - 67" Silty Sand (SM); Light to medium, yellowish brown, moist, dense, occasional inclusions of organic pockets from 9" to 21".</p> <p>67" - 81" Silty Sand (SM); Medium olive gray, moist, moderately dense.</p>	

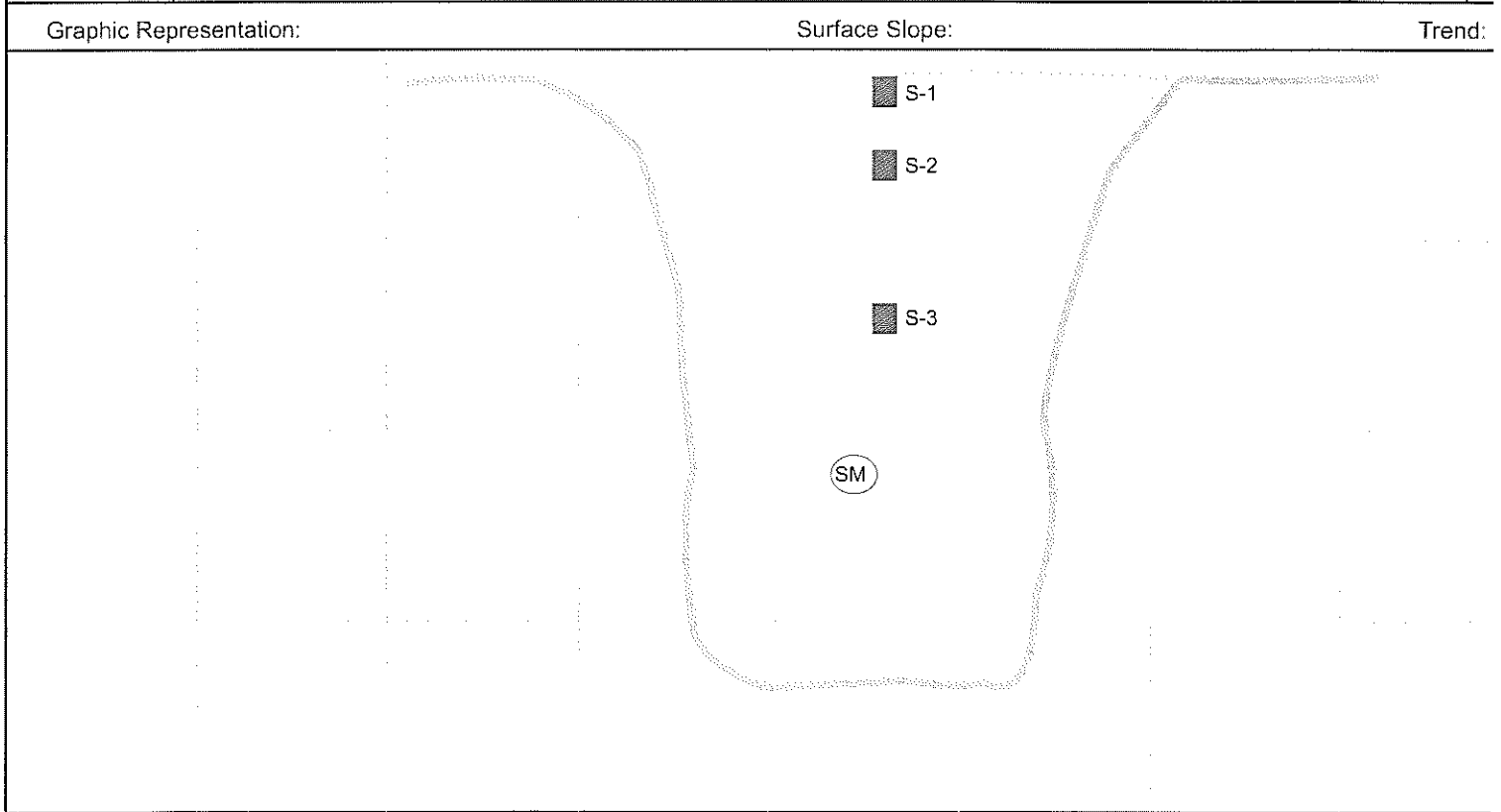

Project Name: Hill Crest Homes Location: De Boer
 Project No.: 1957 Equipment: Backhoe Elevation: _____

Geologic Attitudes	Description	Geologic Unit
	0" - 0.5" Organics (Manure); Dry, loose 0.5" - 8" Silty Sand (SM); Light yellowish brown, dry, very loose, organics 8" - 84" Silty Sand (SM); Medium yellowish brown, moist, moderately dense to dense.	

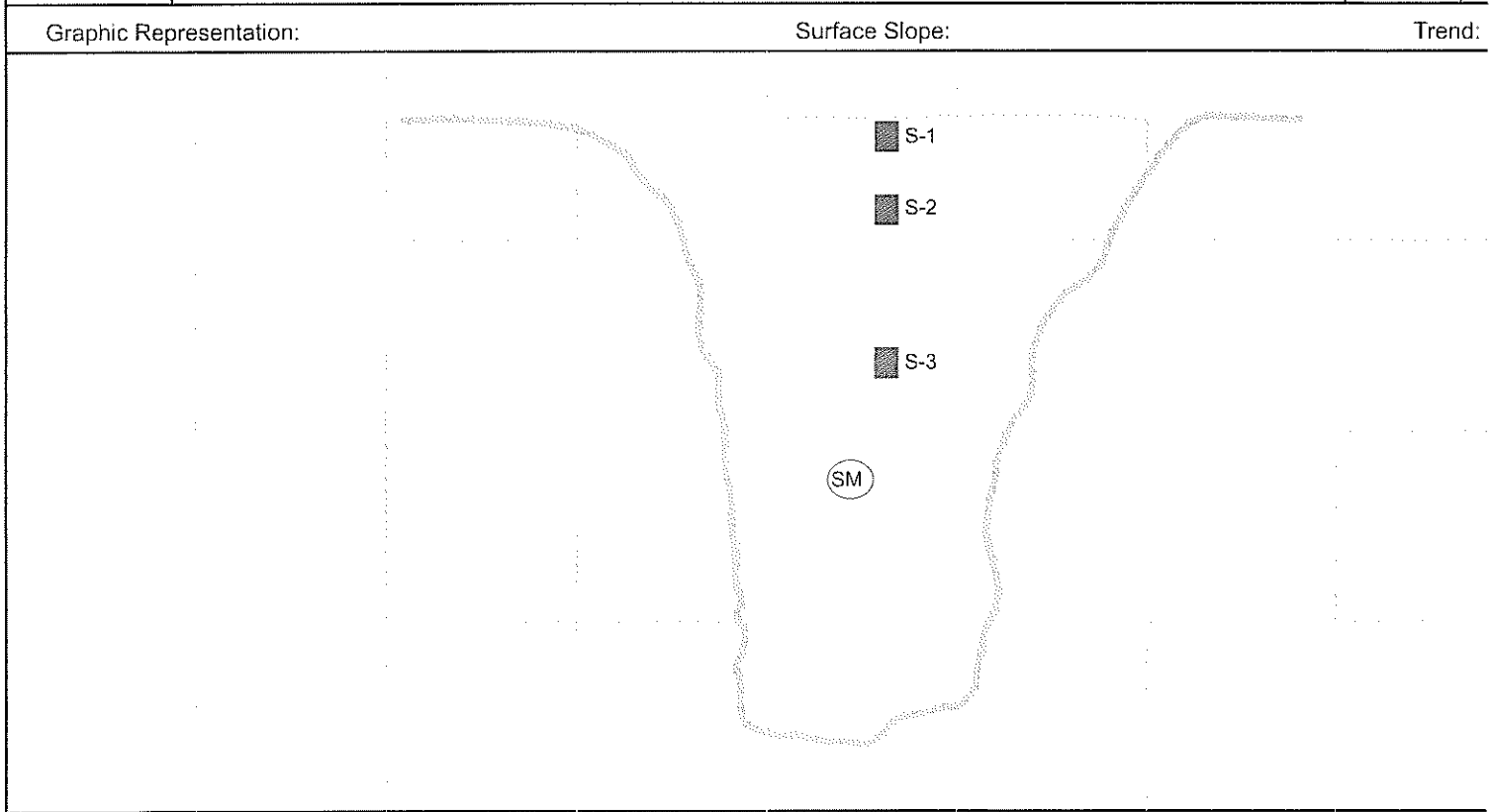

Geologic Attitudes	Description	Geologic Unit
	0.0" - 0.5" Organics (Manure); Dry, loose 0.5" - 9" Silty Sand (SM); Light yellowish brown, dry, very loose, organics 9" - 13" Silty Sand (SM); Medium yellowish brown, moist, dense. 13" - 30" Silty Sand (SM); Medium olive brown, moist, dense, organics. 30" - 60" Same but dark olive brown. 60" - 84" Silty Sand (SM); Medium to dark olive gray, moist to very moist, dense.	

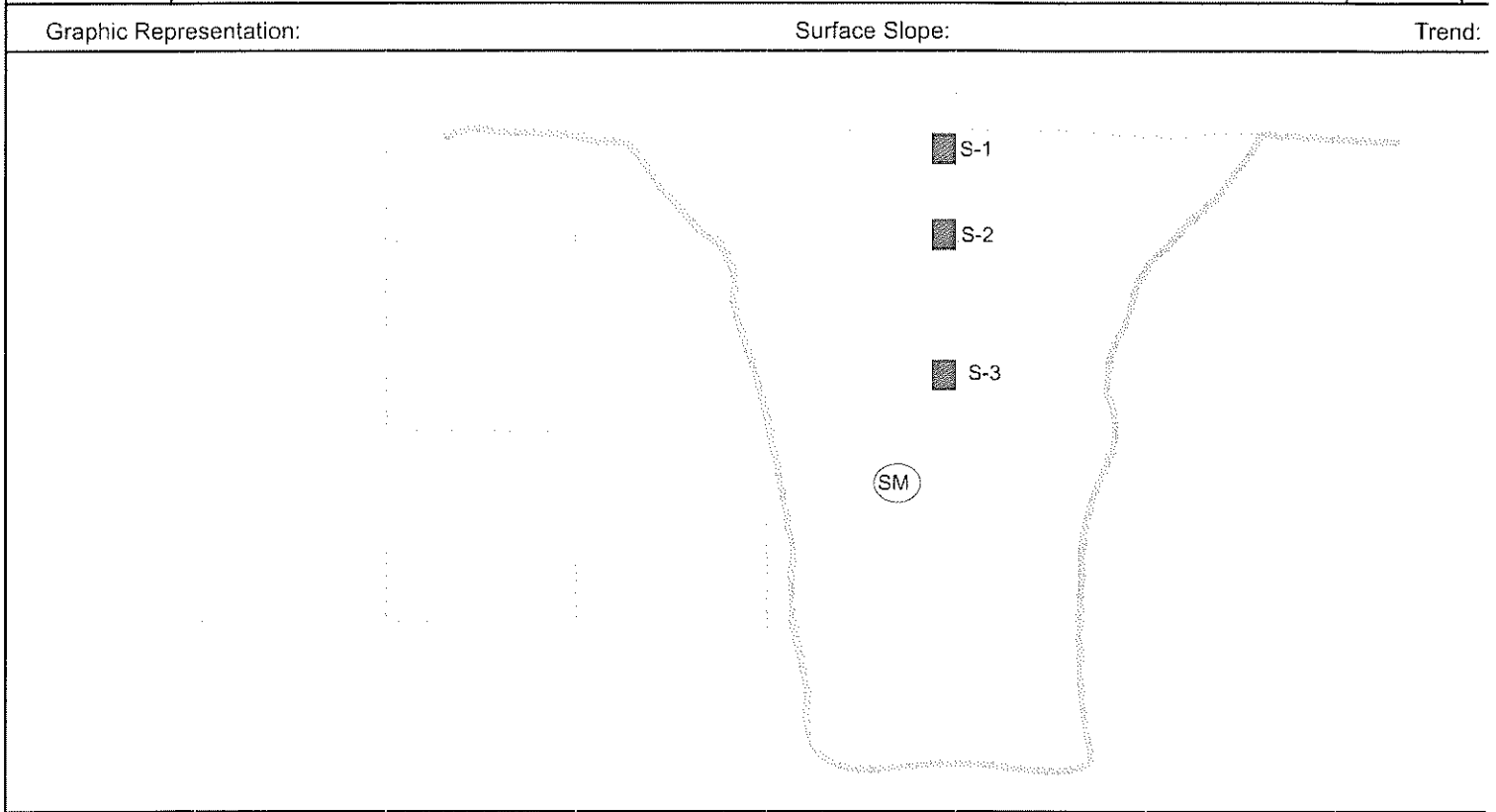

Geologic Attitudes	Description	Geologic Unit
	<p>0.0" - 7" Silty Sand (SM); Light Yellow brown, dry, very loose, organics</p> <p>7" - 32" Silty Sand (SM); Medium yellowish brown, moist, moderately dense to dense.</p> <p>32" - 72" Silty Sand (SM); Medium yellowish brown, moist to very moist, low to moderately dense.</p> <p>72" - 86" Silty Sand with Gravel (SP); Medium yellowish brown, very moist, dense, fine to coarse grained, rounded gravel to 3" diameter. olive brown, moist, dense, organics.</p>	

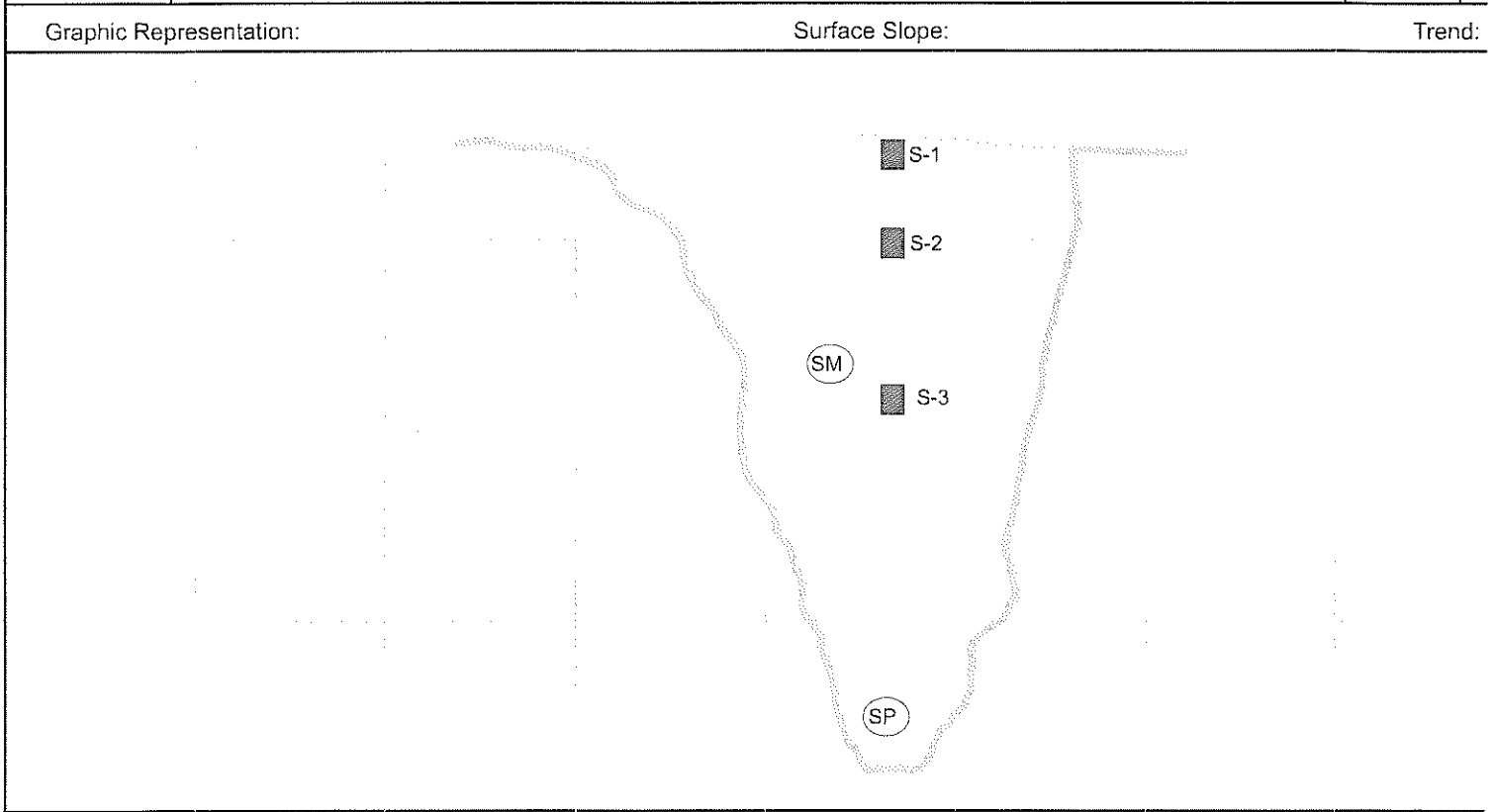

Geologic Attitudes	Description	Geologic Unit
	<p>0.0" - 6" Silty Sand (SM); Light to medium yellowish brown, dry, very loose.</p> <p>6" - 14" Silty Sand (SM); Medium to dark red brown, moist, dense, organics.</p> <p>14" - 39" Silty Sand (SM); Dark brown, moist, dense, organics.</p> <p>39" - 84" Silty Sand (SM); Medium olive brown/gray, moist, loose to moderately dense.</p>	

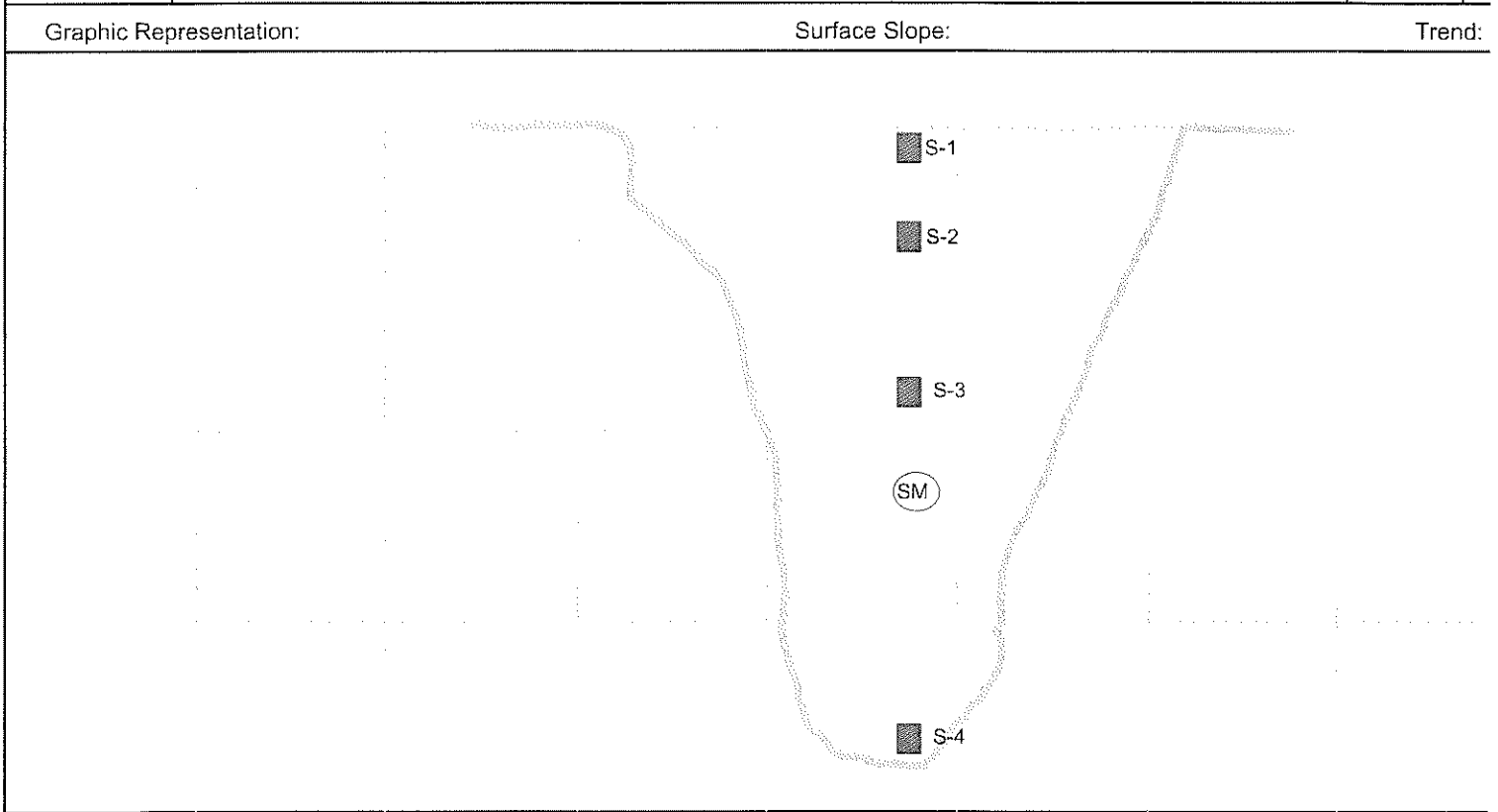

Geologic Attitudes	Description	Geologic Unit U.
	<p>0.0" - 7" Silty Sand (SM); Medium yellowish brown, dry, very loose.</p> <p>7" - 31" Silty Sand (SM); Dark brown, moist, dense, organic.</p> <p>31" - 38" Silty Sand (SM); Dark olive gray, moist, moderately dense, organics.</p> <p>38" - 84" Silty Sand (SM); Medium yellowish brown, moist, dense.</p>	

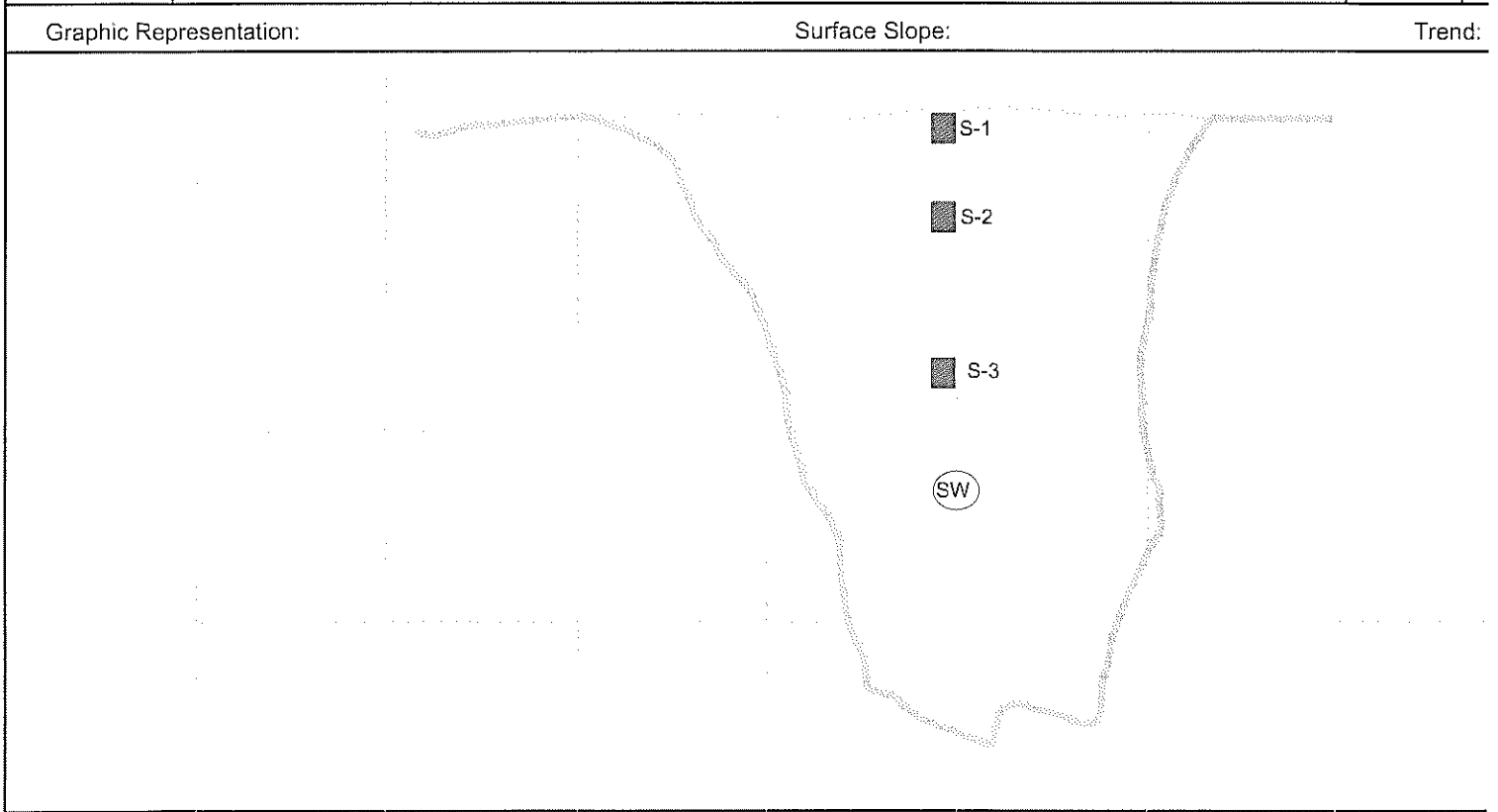

GeoKinetics

Geotechnical &
Environmental Engineers

Project Name: Hill Crest Homes Location: De Boer
Project No.: 1957 Equipment: Backhoe Elevation: _____

Geologic Attitudes	Description	Geologic Unit
	<p>0.0" - 12" Silty Sand (SM); Medium to dark olive brown, moist, loose, organic, rounded gravel.</p> <p>12" - 51" Silty Sand (SM); Medium yellowish brown, moist, dense, occasional gravel (small to large drain, subrounded to rounded), mottled with a dark brown organic silty sand (SM)</p> <p>51" - 84" Silty Sand (SM); Medium olive grey, very moist, moderately dense</p>	<p>U.</p>

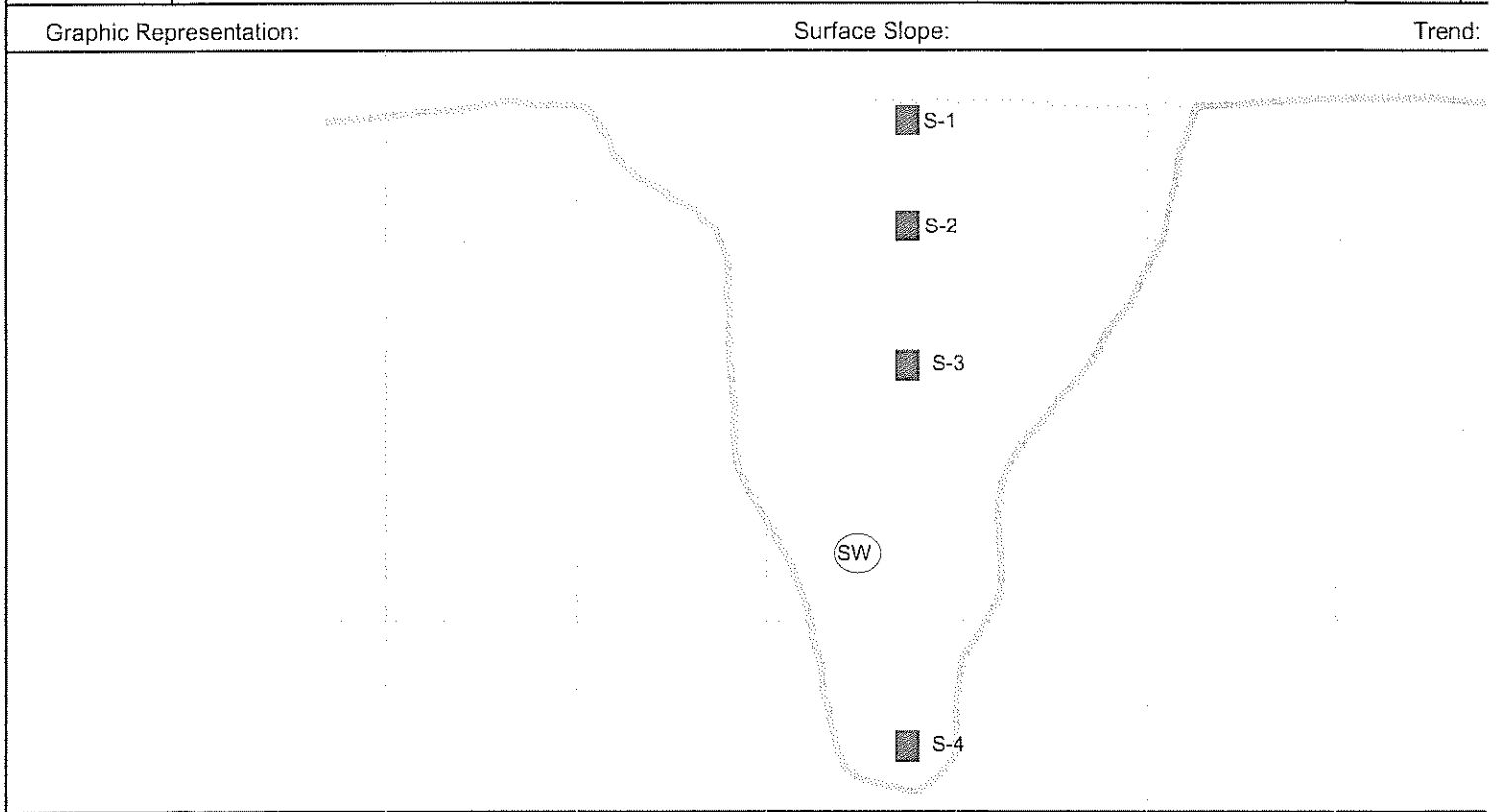

Geologic Attitudes	Description	Geologic Unit
	0.0" - 8" Silty Sand (SM); Medium to brown, moist, loose, organics 8" -34" Silty Sand (SM); Dark brown, moist, dense, organics, trash (pvc pipe, asphalt, etc.) 34" - 84" Silty Sand (SM); Medium red brown, moist, dense. 84" -108" Silty Sand (SM); Olive brown, moist, moderately dense.	

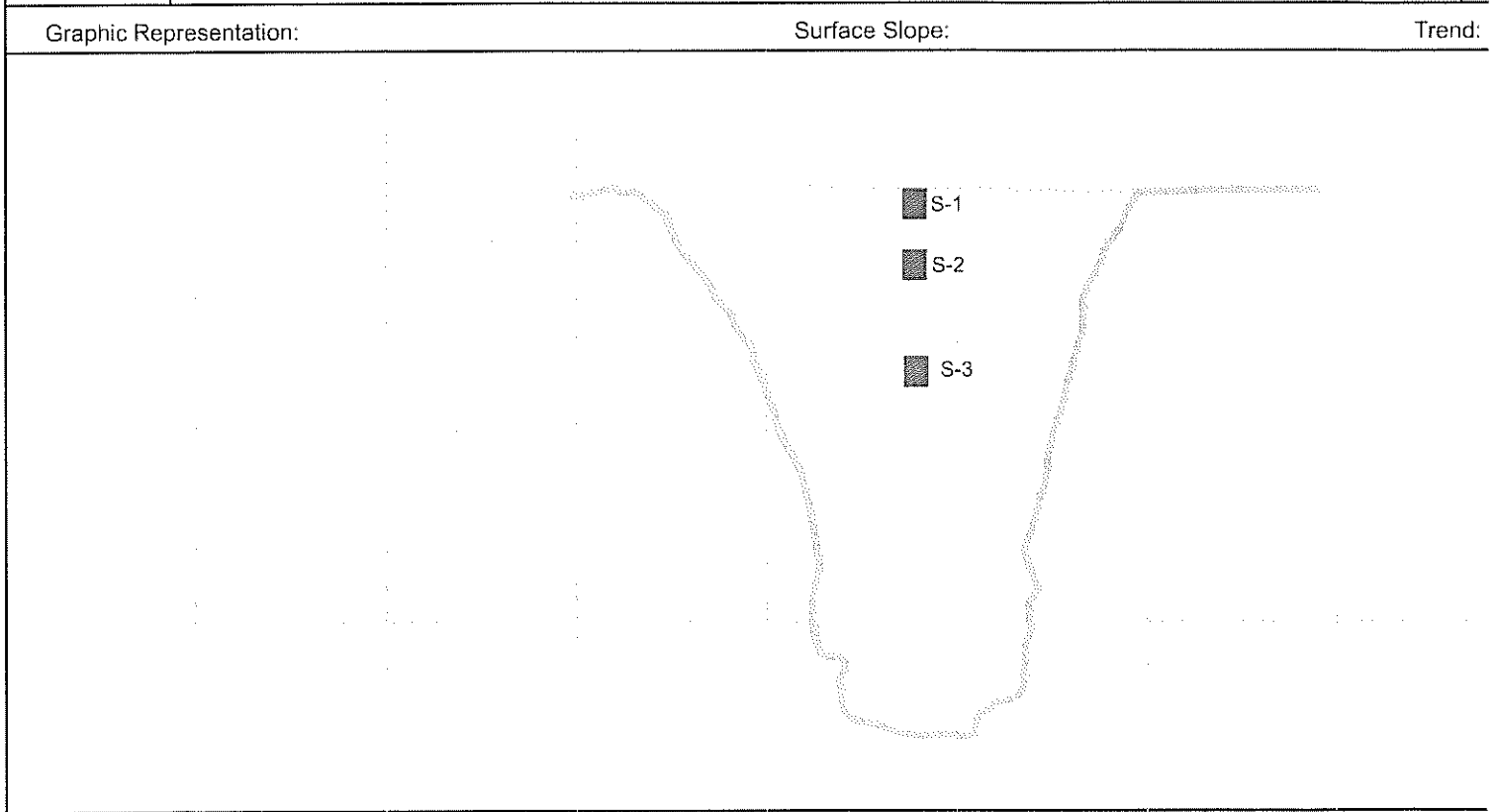

APPENDIX C

Laboratory Testing

LABORATORY TESTING

The following laboratory tests were performed on representative samples in accordance with the applicable latest standards or methods from the ASTM, California Building Code (CBC) and California Department of Transportation.

Classification

Soils were classified with respect to the Unified Soil Classification System (USCS) in accordance with ASTM D-2487 and D-2488.

Particle Size Analysis

Modified hydrometer testing was conducted to aid in classification of the soils. The results of the particle size analysis are presented in Table C-1.

Maximum Density/Optimum Moisture

The maximum dry density and optimum moisture content of three representative bulk samples were evaluated in accordance with ASTM D-1557. The results are summarized in Table C-1.

**TABLE C
SUMMARY OF LABORATORY TEST DATA
P.N. 1-0152**

Boring/Pit No.	Depth	Soil Description	Group Symbol - Unified Soil Classification System	Maximum Dry Density		Direct Shear	Grain Size Analysis				Expansion Index	Sulfate Content (%)	Consolidation	Other Tests Remarks
				Maximum Density (pcf)	Optimum Moisture (%)		Gravel (% + No. 4 Screen)	% Sand	% Silt (0.074 to 0.005mm)	% Clay (-0.005 mm)				
TP-2	4	Silty Sand (Qy)	SM	127	8.1		10	76	10	4				
TP-15	5	Silty Sand (Qy)	SM	128.1	9.2		2	70	19	9				
TP-21	3	Silty Sand (Qy)	SM	126.3	9		0	62	33	5				
TP-24	3	Sandy Silt (Qy)	SM	117.9	10		1	73	23	3				

Alta California Geotechnical, Inc.

APPENDIX C-1

Previous Laboratory Testing

Table 1 - Summary of Laboratory Test Results - Hillcrest - DeBoer

Boring No.	Sample Depth (ft)	USCS ¹ Soil Type	Soil Description	Field Dry Density (pcf)	Field Moisture Content (%)	Degree of Saturation (%)	Compaction ¹		Atterberg Limits		Expansion Index	R Value	pH	Corrosivity			Swell / Collapse on Undisturbed Samples	Direct Shear				Grain Size (%)
							Max. Dry Density (pcf)	Opt. Moisture Content (%)	LL (%)	PL (%)				Min. Resistivity (Ohm-cm)	Sulfate Conc. (ppm)	Chloride Conc. (ppm)		Peak		Ultimate		
																		Cohesion (psf)	Phi (deg)	Cohesion (psf)	Phi (deg)	
GK-1	5.0	SP-SM	Brown Poorly Graded SAND with Silt	106.7	5.7	27.0																
	10.0	GP	Grayish Brown Silty Sandy GRAVEL	120.0	1.5	10.0										0.2% collapse @ .5 ksf load						
	15.0	SP-SM	Light Brown Poorly Graded SAND with Silt	107.3	7.6	36.0															11.5% fines	
	20.0	SC	Brown Clayey SAND	97.5	26.2	97.0																
GK-2	2.5	SM	Dark Brown Silty (fine) SAND (Large Bag)				120.0	10.5														
	5.0	SM/SC	Light Brown Silty SAND with Clay	111.7	14.4	77.0																
	10.0	SM	Light Brown Silty SAND	116.6	11.1	67.0																
	15.0	CL	Brown Sandy CLAY	104.0	21.4	93.0																
GK-3	20.0	CL	Brown Sandy CLAY	101.6	24.5	100.0																
	5.0	CL	Dark Brown Silty SAND with Clay	113.1	15.4	85.0			42	21	52	6.8	730.0	132.0	69.0							
	10.0	SC	Dark Brown Clayey SAND	119.8	11.1	73.0																
	15.0	ML	Brown Sandy SILT	107.4	11.9	56.0																
	20.0	ML	Brown Sandy SILT	113.0	12.7	70.0																
	25.0	ML	Brown Sandy SILT	105.5	21.3	96.0																
	30.0	SM/SC	Dark Brown Silty SAND with Clay	124.6	5.2	40.0																
	35.0	GP	Brown Sandy GRAVEL	126.6	2.2	18.0																
	40.0	SP	Brown Poorly Graded SAND with Gravel	130.1	2.1	19.0																
	45.0	SP-SM	Brown Poorly Graded SAND with Silty and Gravel	119.3	8.0	52.0																
GK-4	50.0	GP	Brown Sandy GRAVEL	121.8	3.0	21.0																
	5.0	SP-SM	Brown Poorly Graded SAND with Silt	110.3	5.0	26.0																
	10.0	SP	Brown Poorly Graded SAND	104.4	2.4	10.0																
	15.0	SP-SM	Brown Poorly Graded SAND with Silt	122.4	1.9	13.0																
GK-5	20.0	SM	Brown Silty (fine) SAND	95.6	10.0	36.0																
	5.0	SP-SM	Dark Gray Poorly Graded SAND with Silt	106.8	9.3	43.0						62.0	6.8	730	132	69						
	10.0	SM	Dark Gray Silty SAND	108.0	9.5	46.0																
	15.0	SP	Grayish Brown Poorly Graded SAND with Gravel	119.2	4.3	28.0																
GK-6	20.0	SC	Dark Brown Clayey SAND	115.8	16.1	95.0																
	5.0	SM	Brown Silty SAND	107.5	6.3	30.0	-	-	-	-	-	-	-	-	-							
	10.0	SP/GP	Brown Sandy GRAVEL	120.8	3.1	21.0	-	-	-	-	-	-	-	-	-							
	15.0	SC	Brown Clayey SAND	116.6	12.6	77.0	-	-	-	-	-	-	-	-	-							
GK-6	20.0	SM	Brown Silty SAND with Gravel	116.7	6.1	37.0	-	-	-	-	-	-	-	-	-							

Table 1 - Summary of Laboratory Test Results - Hillcrest - DeBoer

Boring No.	Sample Depth (ft)	USCS ¹ Soil Type	Soil Description	Field Dry Density (pcf)	Field Moisture Content (%)	Degree of Saturation (%)	Compaction ²		Atterberg Limits		Expansion Index	R Value	Corrosivity			Swell / Collapse on Undisturbed Samples	Direct Shear				Grain Size (%)				
							Max. Dry Density (pcf)	Opt. Moisture Content (%)	LL (%)	PL (%)			pH	Min. Resistivity (ohm-cm)	Sulfate Conc. (ppm)		Chloride Conc. (ppm)	Peak		Ultimate					
																		Cohesion (psf)	Phi (deg)	Cohesion (psf)		Phi (deg)			
GK-7	5.0	SM	Dark Brown Silty SAND	106.2	7.8	36.0									0.2% collapse @ .5 ksf load						55.6% fines				
	10.0	ML	Dark Brown Sandy Silt	107.1	20.7	97.0																			
	15.0	SP-SM	Dark Brown Poorly Graded SAND with Silt and Gravel	111.9	6.4	34.0																			
	20.0	SP	Light Brown Poorly Graded SAND with Gravel	128.1	5.6	48.0																			
GK-8	5.0	SP	Brown Poorly Graded SAND	102.3	3.4	14.0																	3.8% fines		
	10.0	SC	Brown Clayey SAND	115.8	12.4	74.0											857	23.5	581	22.4			48.5% fines		
	15.0	SM	Light Brown Silty SAND with Gravel	117.4	8.8	55.0																			
	20.0	SP-SM	Light Brown Poorly Graded SAND with Silt and Gravel	118.0	3.4	22.0																			
GK-9	5.0	SP	Light Brown Poorly Graded SAND with Gravel	113.3	3.0	16.0																			
	10.0	SP	Light Brown Poorly Graded SAND with Gravel	110.6	3.7	19.0					35.0														
	15.0	SP-SM	Light Brown Poorly Graded SAND with Silt and Gravel	105.8	3.7	17.0																			
	20.0	CL	Light Brown Sandy CLAY	94.3	28.6	98.0																			
GK-10	5.0	SM	Light Brown Silty SAND with Gravel	121.0	2.9	20.0																		14.9% fines	
	10.0	SC	Light Brown Clayey SAND	119.6	10.5	69.0																			
	15.0	GP	Light Brown Sandy GRAVEL	131.6	3.6	35.0																			4.8% fines
	20.0	SM	Light Brown Silty (fine) SAND	103.4	18.5	49.0																			
	25.0	SM	Light Brown Silty (fine) SAND	104.6	7.6	34.0																			
	30.0	SC	Light Brown Clayey SAND	109.3	19.8	99.0																			
	35.0	CL	Light Brown Silty CLAY	109.7	19.0	94.0																			46.5% fines
	40.0	CL	Light Brown Sandy CLAY	111.1	19.2	99.0																			
45.0	CL	Light Brown Sandy CLAY	115.9	12.0	71.0																				
50.0	CL	Light Brown Silty CLAY	111.2	17.9	94.0																				
GK-11	5.0	SM	Dark Brown Silty (fine) SAND	103.7	8.1	35.0																			
	10.0	SM	Dark Brown Clayey SAND	117.6	14.0	87.0																			
	15.0	SP	Brown Silty SAND	126.5	5.0	41.0																			
	20.0	SC	Light Brown Poorly Graded SAND with Gravel	121.8	3.6	25.0																			
GK-12	5.0	SP-SM	Dark Brown Poorly Graded SAND with Silt and Gravel	115.4	8.5	50.0																			
	10.0	SP/GP	Light Brown Poorly Graded SAND with Gravel	118.0	2.3	14.0																			
	15.0	SC	Grayish Brown Poorly Graded SAND with Silt	121.2	2.7	19.0																			
	20.0	SM	Light Brown Sandy CLAY	110.4	19.6	100.0																			11.8% fines

Project Name : Deboer
Summary of Expansion Index Tests

Location	Depth/Elev	Sample Description	EI
GK-3	5.0 Ft.	Dark Brown Sandy CLAY (CL)	52
GK-3	10.0 Ft.	Dark Brown Clayey SAND (SC)	38
GK-9	10.0 Ft.	Dark Brown Clayey SAND (SC)	35

Job No. 1957 Date 11/19/04
 Project Deboer

Source of Material GK-2 @ 2.5'
 Description of Material Dark Brown Silty (fine) SAND (SM) Large bag
 Test Method (ASTM) D 1557-93-A

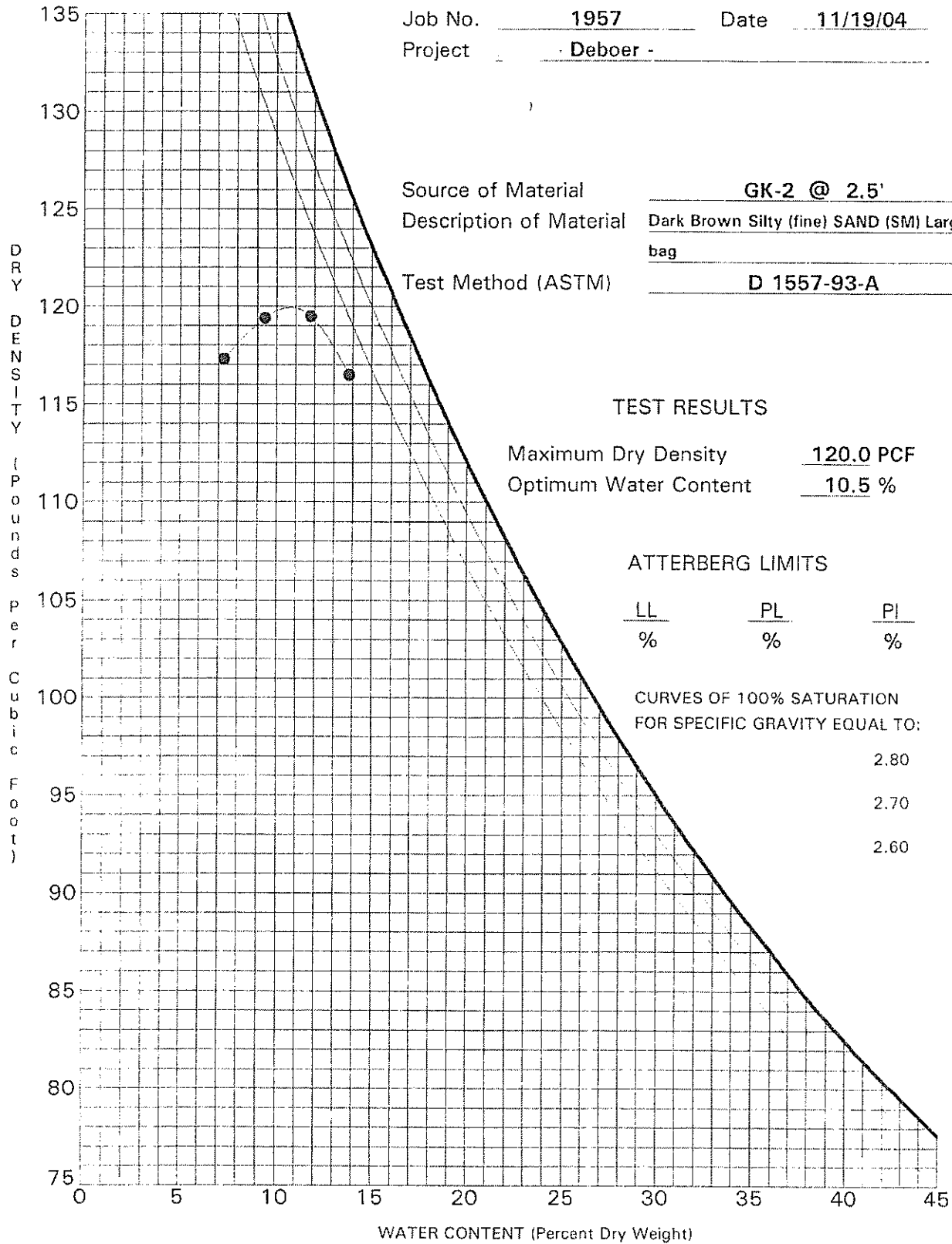

MOISTURE-DENSITY RELATIONSHIP

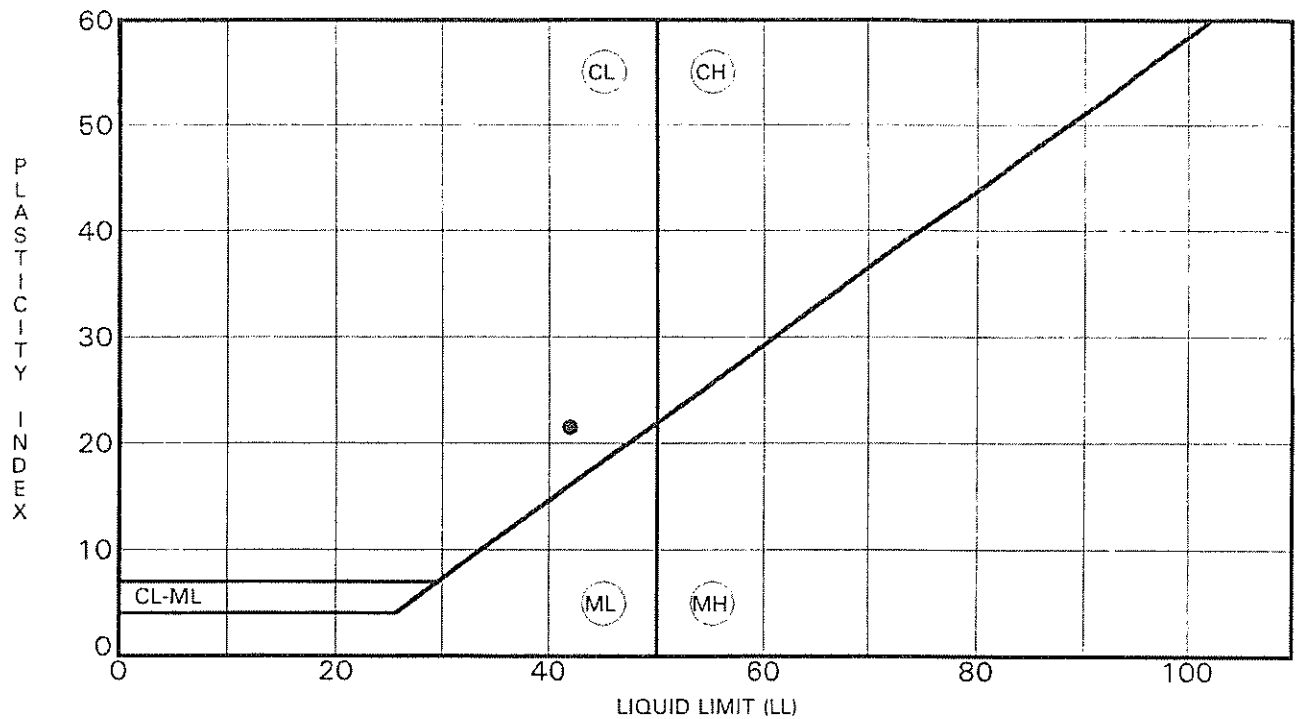

Specimen Identification	LL	PL	PI	Fines	Classification
● GK-3 5.0	42	21	22		Dark Brown Sandy CLAY (CL)

PROJECT Deboer

JOB NO. 1957
DATE 11/19/04

ATTERBERG LIMITS' RESULTS

IRVINE, CA

Tested by: _____ Project Description: _____

Location: _____

Borehole Depth Elev.	Specimen Description				Wet Density	Dry Density	Water Content	Specific Gravity	Sample Data		
	LL	PL	PI	Fines					% Saturation	Void Ratio	Porosity
GK-1 5.0	Brown Poorly Graded SAND with Silt (SP-SM) 11.5				112.7	106.7	5.7		26.5	0.58	
GK-1 10.0	Grayish Brown Sandy GRAVEL (GP)				121.8	120.0	1.5		9.9	0.40	
GK-1 15.0	Light Brown Poorly Graded SAND with Silt (SP-SM)				115.5	107.3	7.6		36.0	0.57	
GK-1 20.0	Brown Clayey SAND (SC)				123.0	97.5	26.2		97.1	0.73	

Summary of Material Properties

GeoKinetics
Geotechnical & Environmental Engineers

Project: **Deboer**Job Number: **1957**Sheet **1** of **1**

Tested by: _____

Project Description: _____

Location: _____

Borehole Depth Elev.	Specimen Description				Wet Density	Dry Density	Water Content	Specific Gravity	Sample Data		
	LL	PL	PI	Fines					% Saturation	Void Ratio	Porosity
GK-2 2.5	Dark Brown Silty (fine) SAND (SM) Large bag										
GK-2 5.0	Light Brown Silty SAND with Clay (SM/SC)				127.8	111.7	14.4		76.6	0.51	
GK-2 10.0	Light Brown Silty SAND (SM)				129.5	116.6	11.1		67.1	0.45	
GK-2 15.0	Brown Sandy CLAY (CL)										
				77.4	126.2	104.0	21.4		92.9	0.62	
GK-2 20.0	Brown Sandy CLAY (CL)										
				76.6	126.4	101.6	24.5		100.1	0.66	

Summary of Material Properties

GeoKinetics
Geotechnical & Environmental Engineers

Tested by: _____ Project Description: _____
 Location: _____

Borehole Depth Elev.	Specimen Description				Wet Density	Dry Density	Water Content	Specific Gravity	Sample Data		
	LL	PL	PI	Fines					% Saturation	Void Ratio	Porosity
GK-3 5.0	Dark Brown Sandy CLAY (CL)				130.5	113.1	15.4		84.6	0.49	
GK-3 10.0	Dark Brown Clayey SAND (SC)				133.1	119.8	11.1		73.6	0.41	
GK-3 15.0	Brown Sandy SILT (ML)				120.2	107.4	11.9		56.2	0.57	
GK-3 20.0	Brown Sandy SILT (ML) 50.7				127.4	113.0	12.7		69.9	0.49	
GK-3 25.0	Brown Sandy SILT (ML) 53.2				127.9	105.5	21.3		96.0	0.60	
GK-3 30.0	Dark Brown Silty SAND with Clay (Sm/SC)				131.0	124.6	5.2		39.5	0.35	
GK-3 35.0	Brown Sandy GRAVEL (GP)				129.3	126.6	2.2		17.6	0.33	
GK-3 40.0	Brown Poorly Graded SAND with Gravel (SP)				132.8	130.1	2.1		18.7	0.30	
GK-3 45.0	Brown Poorly Graded SAND with Silt and Gravel (SP-SM)				128.8	119.3	8.0		52.1	0.41	
GK-3 50.0	Brown Sandy GRAVEL (GP)				125.5	121.8	3.0		21.0	0.38	

Tested by: _____ Project Description: _____
 Location: _____

Borehole Depth Elev.	Specimen Description				Wet Density	Dry Density	Water Content	Specific Gravity	Sample Data		
	LL	PL	PI	Fines					% Saturation	Void Ratio	Porosity
GK-4 5.0	Brown Poorly Graded SAND with Silt (SP-SM)				115.8	110.3	5.0		25.5	0.53	
GK-4 10.0	Brown Poorly Graded SAND (SP) 2.1				106.8	104.4	2.4		10.3	0.61	
GK-4 15.0	Brown Poorly Graded SAND with Silt (SP-SM)				124.6	122.4	1.9		13.2	0.38	
GK-4 20.0	Brown Silty (fine) SAND (SM)				106.3	96.6	10.0		36.2	0.74	

Tested by: _____ Project Description: _____

Location: _____

Borehole Depth Elev.	Specimen Description				Wet Density	Dry Density	Water Content	Specific Gravity	Sample Data		
	LL	PL	PI	Fines					% Saturation	Void Ratio	Porosity
GK-5 5.0	Dark Gray Poorly Graded SAND with Silt (SP-SM) 11.9				116.6	106.8	9.3		43.1	0.58	
GK-5 10.0	Dark Gray Silty SAND (SM)				118.3	108.0	9.5		45.8	0.56	
GK-5 15.0	Grayish Brown Poorly Graded SAND with Gravel (SP)				124.3	119.2	4.3		28.0	0.41	
GK-5 20.0	Dark Brown Clayey SAND (SC)				134.4	115.8	16.1		95.3	0.46	

Summary of Material Properties

GeoKinetics
Geotechnical & Environmental Engineers

Tested by: _____ Project Description: _____
 Location: _____

Borehole Depth Elev.	Specimen Description				Wet Density	Dry Density	Water Content	Specific Gravity	Sample Data		
	LL	PL	PI	Fines					% Saturation	Void Ratio	Porosity
GK-6 5.0	Brown Silty SAND (SM) 14.3				114.3	107.5	6.3		30.0	0.57	
GK-6 10.0	Brown Sandy GRAVEL (SP/GP)				124.5	120.8	3.1		20.9	0.40	
GK-6 15.0	Brown Clayey SAND (SC)				131.3	116.6	12.6		76.5	0.45	
GK-6 20.0	Brown Silty SAND with Gravel (SM)				123.9	116.7	6.1		37.1	0.44	

Project: **Deboer**

Job Number: **1957**

Sheet **1** of **1**

Tested by: _____ Project Description: _____

Location: _____

Borehole Depth Elev.	Specimen Description				Wet Density	Dry Density	Water Content	Specific Gravity	Sample Data		
	LL	PL	PI	Fines					% Saturation	Void Ratio	Porosity
GK-7 5.0	Dark Brown Silty SAND (SM)				114.4	106.2	7.8		35.7	0.59	
GK-7 10.0	Dark Brown Sandy SILT (ML) 55.6				129.2	107.1	20.7		97.4	0.57	
GK-7 15.0	Dark Brown Poorly Graded SAND with Silt and Gravel (SP-SM)				119.1	111.9	6.4		34.3	0.51	
GK-7 20.0	Light Brown Poorly Graded SAND with Gravel (SP)				135.3	128.1	5.6		47.6	0.32	

Summary of Material Properties

GeoKinetics
Geotechnical & Environmental Engineers

Tested by: _____ Project Description: _____

Location: _____

Borehole Depth Elev.	Specimen Description				Wet Density	Dry Density	Water Content	Specific Gravity	Sample Data		
	LL	PL	PI	Fines					% Saturation	Void Ratio	Porosity
GK-8 5.0	Brown Poorly Graded SAND (SP) 3.8				105.7	102.3	3.4		14.0	0.65	
GK-8 10.0	Brown Clayey SAND (SC) 48.5				130.2	115.8	12.4		73.7	0.46	
GK-8 15.0	Light Brown Silty SAND with Gravel (SM)				127.8	117.4	8.8		54.6	0.44	
GK-8 20.0	Light Brown Poorly Graded SAND with Silt and Gravel (SP-SM)				122.0	118.0	3.4		21.6	0.43	

Summary of Material Properties

GeoKinetics
Geotechnical & Environmental Engineers

Tested by: _____ Project Description: _____
 Location: _____

Borehole Depth Elev.	Specimen Description				Wet Density	Dry Density	Water Content	Specific Gravity	Sample Data		
	LL	PL	PI	Fines					% Saturation	Void Ratio	Porosity
GK-9 5.0	Light Brown Poorly Graded SAND with Gravel (SP)				116.7	113.3	3.0		16.4	0.49	
GK-9 10.0	Light Brown Poorly Graded SAND with Gravel (SP)				114.7	110.6	3.7		18.9	0.52	
GK-9 15.0	Light Brown Poorly Graded SAND with Silt and Gravel (SP-SM)				109.7	105.8	3.7		16.7	0.59	
GK-9 20.0	Light Brown Sandy CLAY (CL)				121.3	94.3	28.6		98.1	0.79	

Tested by: _____ Project Description: _____

Location: _____

Borehole Depth Elev.	Specimen Description				Wet Density	Dry Density	Water Content	Specific Gravity	Sample Data		
	LL	PL	PI	Fines					% Saturation	Void Ratio	Porosity
GK-10 5.0	Light Brown Silty SAND with Gravel (SM) 14.9				124.4	121.0	2.9		19.7	0.39	
GK-10 10.0	Light Brown Clayey SAND (SC)				132.2	119.6	10.5		69.2	0.41	
GK-10 15.0	Light Brown Sandy GRAVEL (GP) 4.9				136.4	131.6	3.6		34.8	0.28	
GK-10 20.0	Light Brown Silty (fine) SAND (SM)				122.5	103.4	18.5		79.1	0.63	
GK-10 25.0	Light Brown Silty (fine) SAND (SM)				112.6	104.6	7.6		33.6	0.61	
GK-10 30.0	Light Brown Clayey SAND (SC) 46.5				131.0	109.3	19.8		98.7	0.54	
GK-10 35.0	Light Brown Silty CLAY (CL)				130.5	109.7	19.0		94.3	0.55	
GK-10 40.0	Light Brown Sandy CLAY (CL)				132.4	111.1	19.2		98.8	0.53	
GK-10 45.0	Light Brown Sandy CLAY (CL)				129.8	115.9	12.0		71.2	0.45	
GK-10 50.0	Light Brown Silty CLAY (CL)				131.1	111.2	17.9		93.6	0.52	

Summary of Material Properties

GeoKinetics
Geotechnical & Environmental Engineers

Tested by: _____ Project Description: _____

Location: _____

Borehole Depth Elev.	Specimen Description				Wet Density	Dry Density	Water Content	Specific Gravity	Sample Data		
	LL	PL	PI	Fines					% Saturation	Void Ratio	Porosity
GK-11 5.0	Dark Brown Silty (fine) SAND (SM)				112.1	103.7	8.1		34.9	0.63	
GK-11 10.0	Dark Brown Clayey SAND (SC)				134.1	117.6	14.0		87.1	0.43	
GK-11 15.0	Brown Silty SAND (SM) 18.4				132.9	126.5	5.0		41.0	0.33	
GK-11 20.0	Light Brown Poorly Graded SAND with Gravel (SP)				126.1	121.8	3.6		25.2	0.38	

Summary of Material Properties

GeoKinetics
Geotechnical & Environmental Engineers

Tested by: _____

Project Description: _____

Location: _____

Borehole Depth Elev.	Specimen Description				Wet Density	Dry Density	Water Content	Specific Gravity	Sample Data		
	LL	PL	PI	Fines					% Saturation	Void Ratio	Porosity
GK-12 5.0	Dark Brown Poorly Graded SAND with Silt and Gravel (SP-SM)				125.2	115.4	8.5		49.5	0.46	
GK-12 10.0	Light Brown Poorly Graded SAND with Gravel (SP)				120.7	118.0	2.3		14.4	0.43	
GK-12 15.0	Grayish Brown Poorly Graded SAND with Silt (SP-SM)				124.5	121.2	2.7		18.8	0.39	
GK-12 20.0	Light Brown Sandy CLAY (CL)				132.0	110.4	19.6		99.1	0.54	

Summary of Material Properties

GeoKinetics
Geotechnical & Environmental Engineers

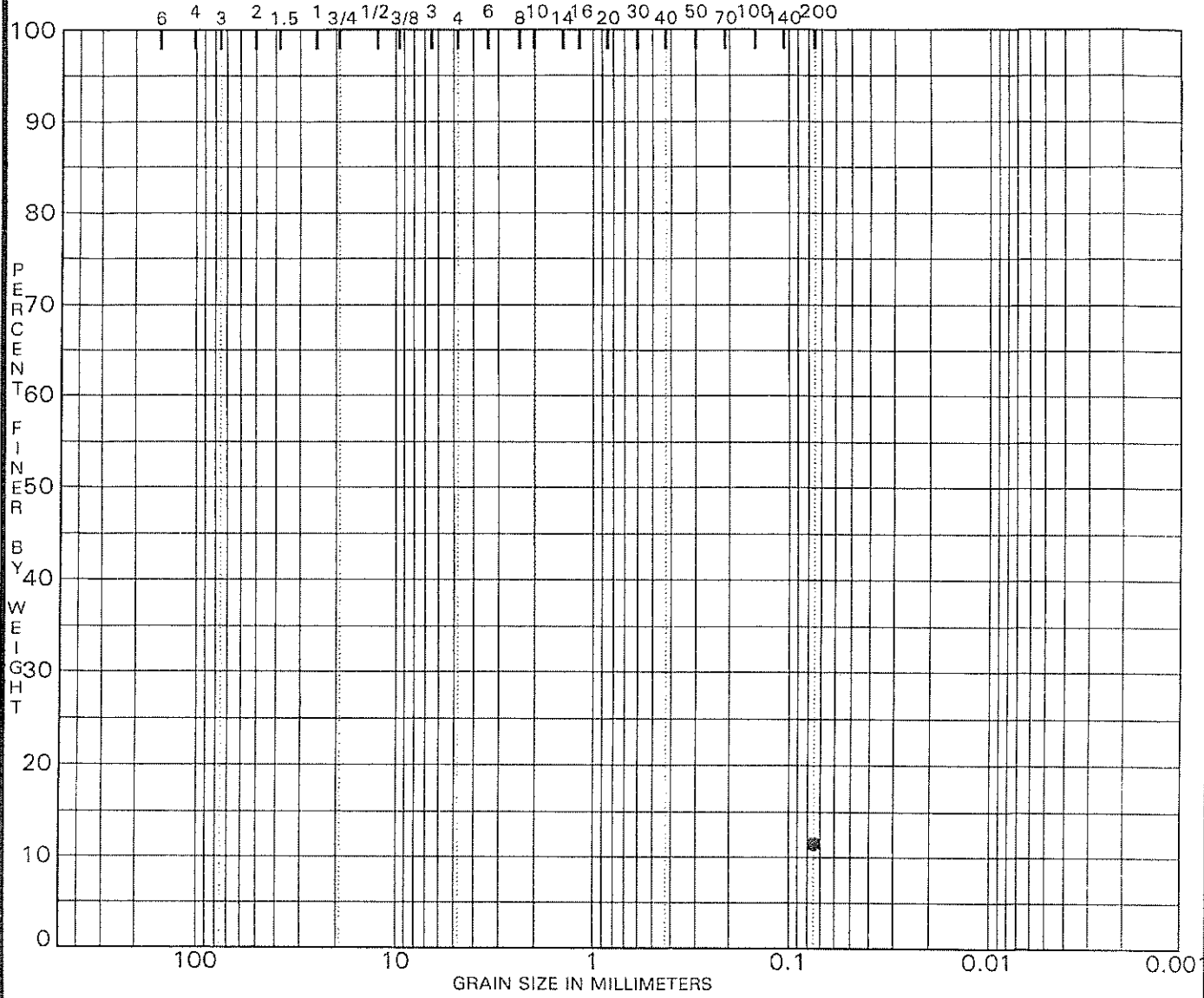

COBBLES	GRAVEL		SAND			SILT OR CLAY
	coarse	fine	coarse	medium	fine	

Specimen Identification	Classification						
● GK-1 5.0	Brown Poorly Graded SAND with Silt (SP-SM)						

Specimen Identification	D100	D60	D30	D10	%Gravel	%Sand	%Silt	%Clay
● GK-1 5.0							11.5	

PROJECT Deboer JOB NO. 1957
 DATE 10/19/04

GRADATION CURVES

U.S. Sieve Opening in Inches

U.S. Sieve Numbers

Centimeters

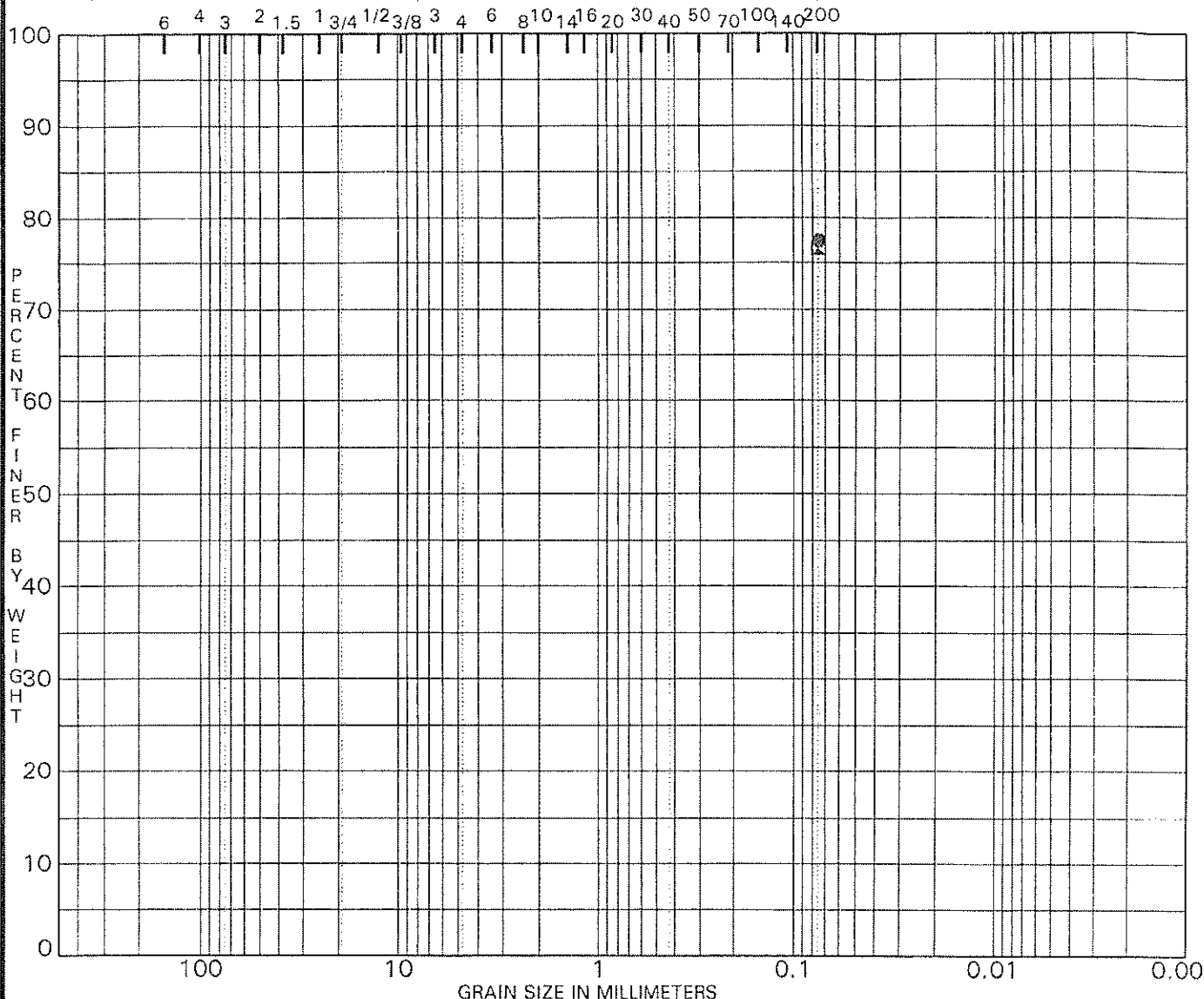

COBBLES	GRAVEL		SAND			SILT OR CLAY
	coarse	fine	coarse	medium	fine	

Specimen Identification	Classification
● GK-2 15.0	Brown Sandy CLAY (CL)
☒ GK-2 20.0	Brown Sandy CLAY (CL)

Specimen Identification	D100	D60	D30	D10	%Gravel	%Sand	%Silt	%Clay
● GK-2 15.0							77.4	
☒ GK-2 20.0							76.6	

PROJECT Deboer JOB NO. 1957
 DATE 10/19/04

GRADATION CURVES

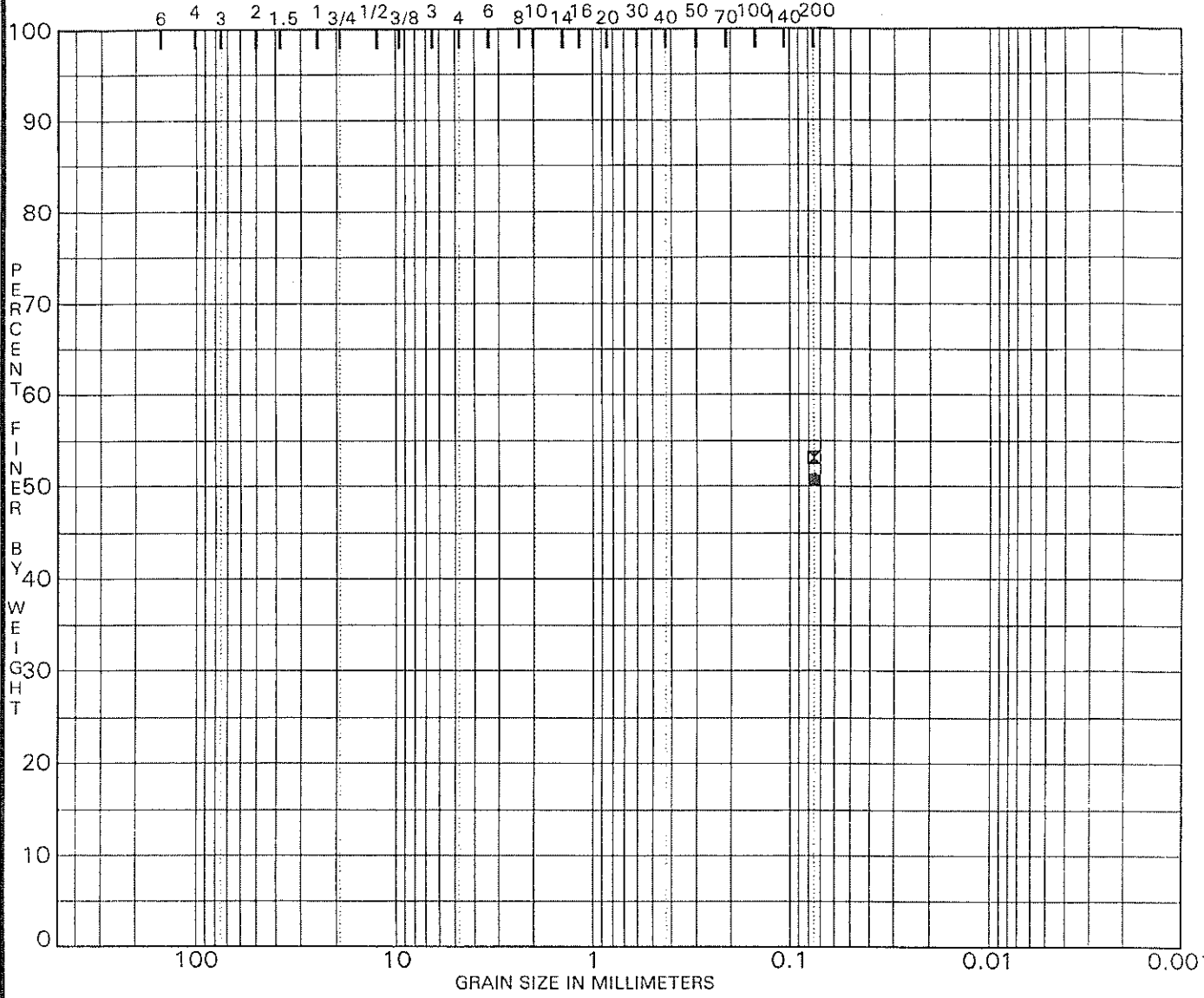

COBBLES	GRAVEL		SAND			SILT OR CLAY
	coarse	fine	coarse	medium	fine	

Specimen Identification	Classification	
● GK-3 20.0	Brown Sandy SILT (ML)	
☒ GK-3 25.0	Brown Sandy SILT (ML)	

Specimen Identification	D100	D60	D30	D10	%Gravel	%Sand	%Silt	%Clay
● GK-3 20.0							50.7	
☒ GK-3 25.0							53.2	

PROJECT Deboer JOB NO. 1957
 DATE 10/19/04

GRADATION CURVES

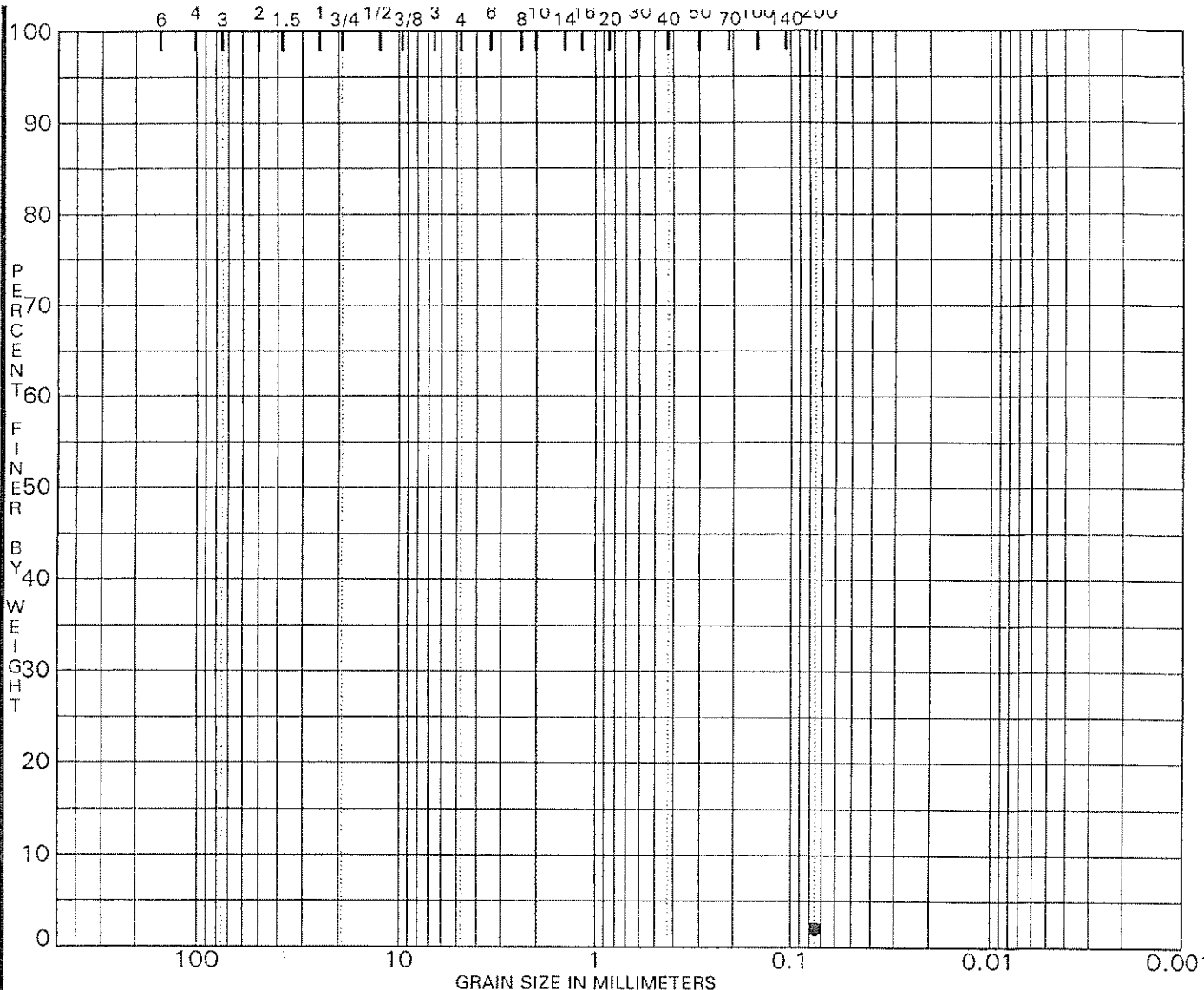

COBBLES	GRAVEL		SAND			SILT OR CLAY
	coarse	fine	coarse	medium	fine	

Specimen Identification		Classification					
●	GK-4 10.0	Brown Poorly Graded SAND (SP)					

Specimen Identification		D100	D60	D30	D10	%Gravel	%Sand	%Silt	%Clay
●	GK-4 10.0							2.1	

PROJECT Deboer JOB NO. 1957
 DATE 10/19/04

GRADATION CURVES

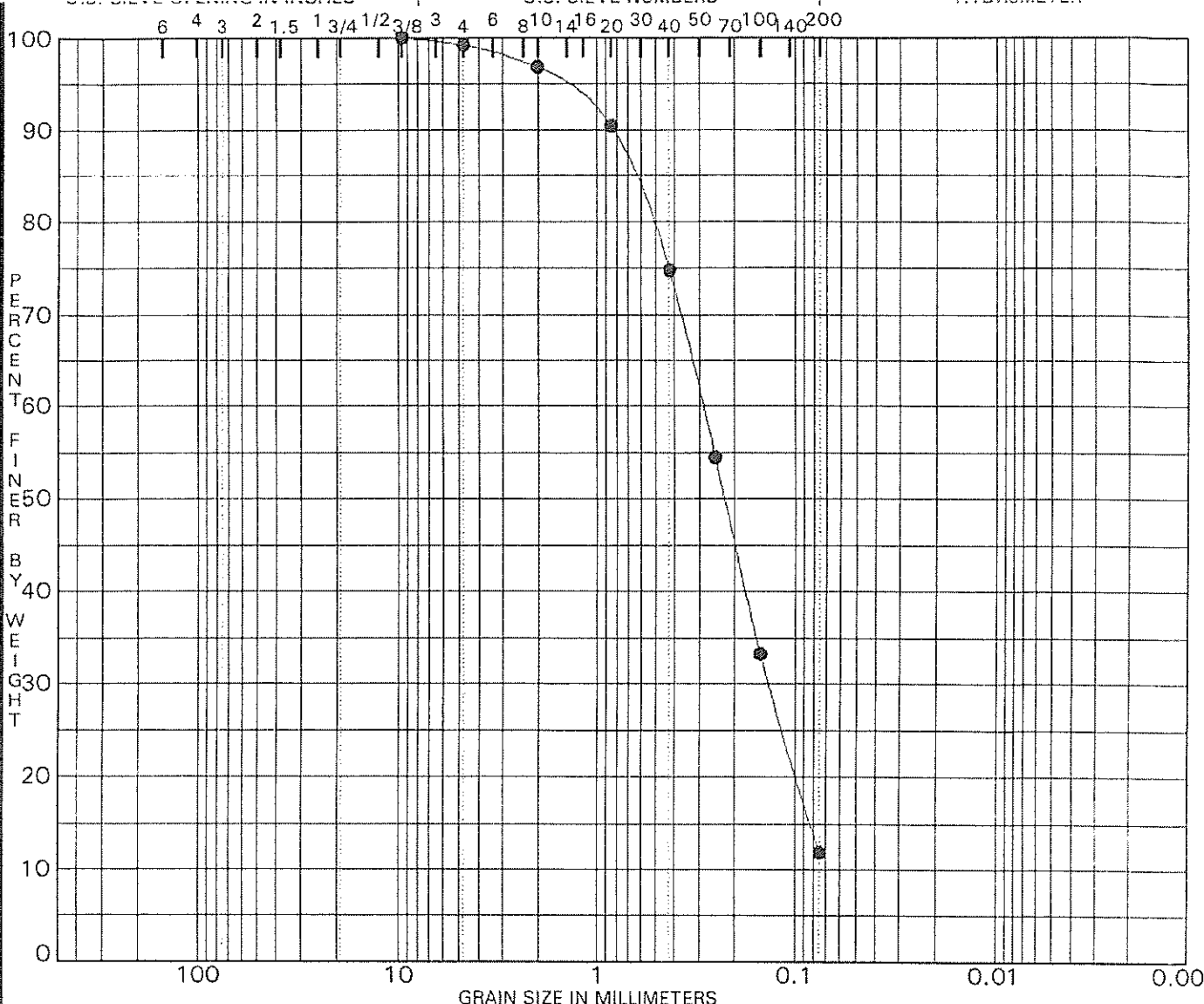

COBBLES	GRAVEL		SAND			SILT OR CLAY
	coarse	fine	coarse	medium	fine	

Specimen Identification	Classification
● GK-5 5.0	Dark Gray Poorly Graded SAND with Silt (SP-SM)

Specimen Identification	D100	D60	D30	D10	%Gravel	%Sand	%Silt	%Clay
● GK-5 5.0	9.50	0.29	0.135		0.8	87.3	11.9	

PROJECT Deboer JOB NO. 1957
 DATE 10/19/04

GRADATION CURVES

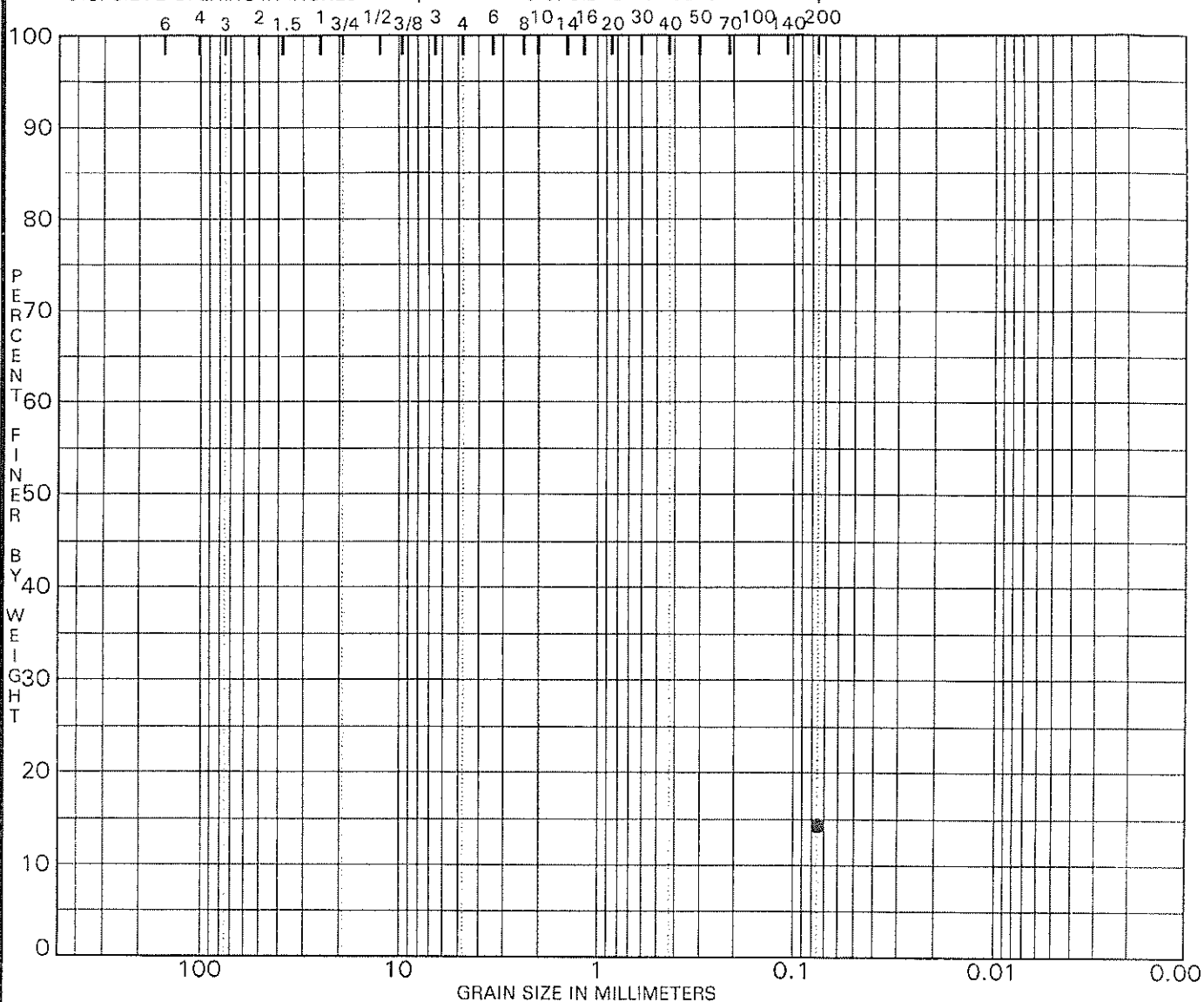

COBBLES	GRAVEL		SAND			SILT OR CLAY
	coarse	fine	coarse	medium	fine	

Specimen Identification	Classification						
● GK-6 5.0	Brown Silty SAND (SM)						

Specimen Identification	D100	D60	D30	D10	%Gravel	%Sand	%Silt	%Clay
● GK-6 5.0							14.3	

PROJECT Deboer JOB NO. 1957
 DATE 10/19/04

GRADATION CURVES

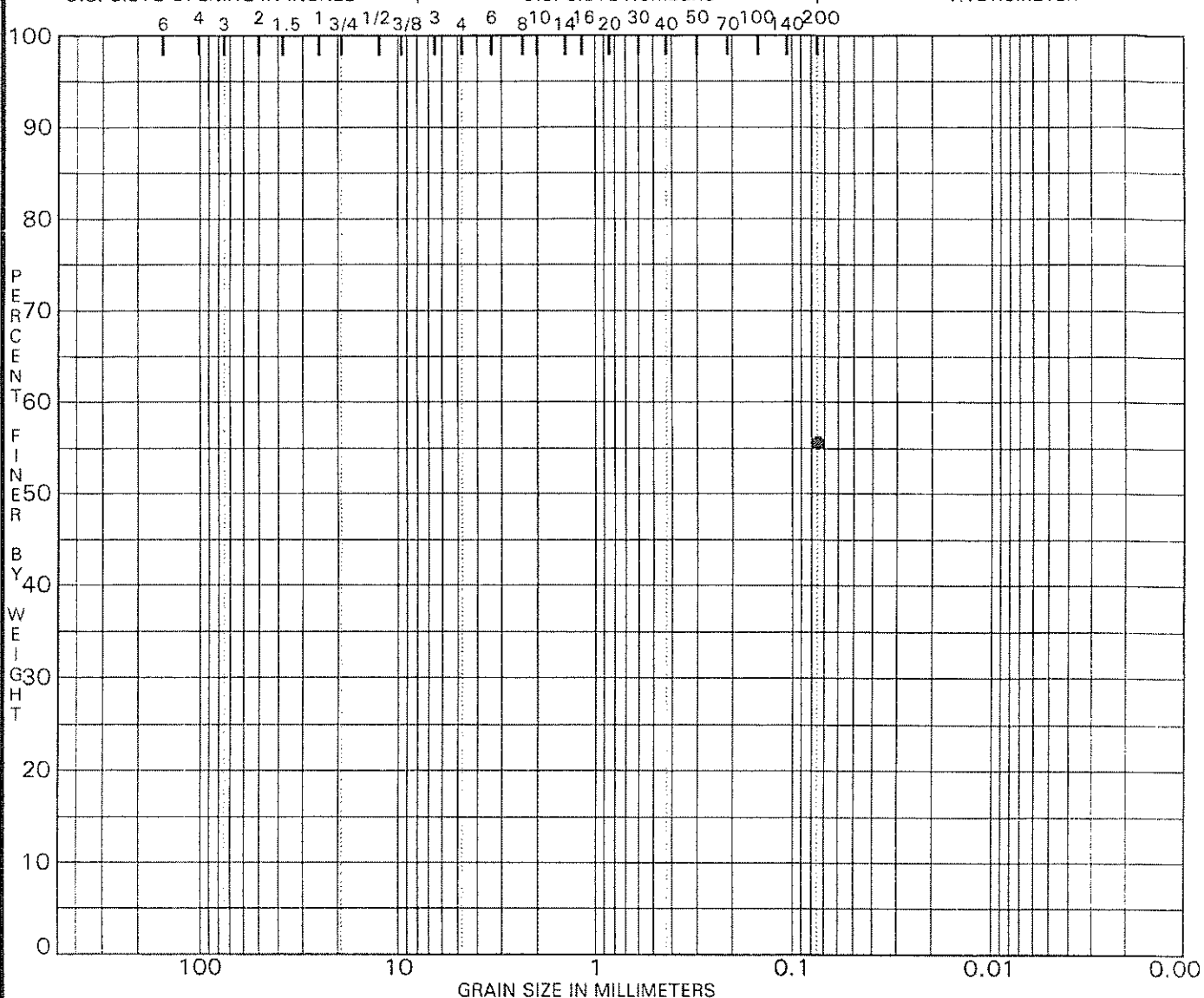

COBBLES	GRAVEL		SAND			SILT OR CLAY
	coarse	fine	coarse	medium	fine	

Specimen Identification	Classification						
● GK-7 10.0	Dark Brown Sandy SILT (ML)						

Specimen Identification	D100	D60	D30	D10	%Gravel	%Sand	%Silt	%Clay
● GK-7 10.0							55.6	

PROJECT Deboer JOB NO. 1957
 DATE 10/19/04

GRADATION CURVES

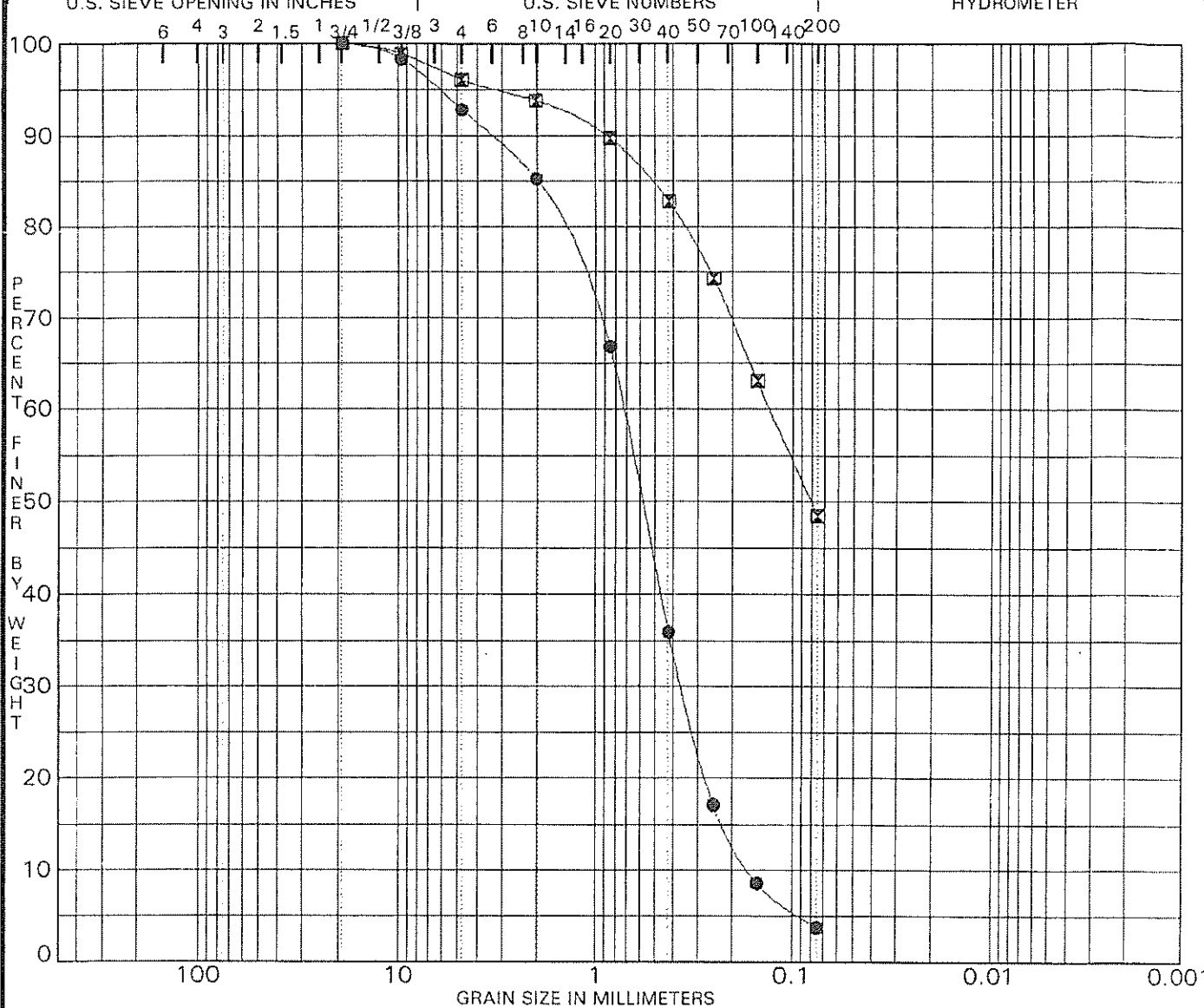

COBBLES	GRAVEL		SAND			SILT OR CLAY
	coarse	fine	coarse	medium	fine	

Specimen Identification			Classification							
●	GK-8	5.0	Brown Poorly Graded SAND (SP)							
☒	GK-8	10.0	Brown Clayey SAND (SC)							
Specimen Identification			D100	D60	D30	D10	%Gravel	%Sand	%Silt	%Clay
●	GK-8	5.0	19.00	0.73	0.360	0.1632	7.2	89.0	3.8	
☒	GK-8	10.0	19.00	0.13			3.9	47.6	48.5	

PROJECT Deboer

JOB NO. 1957
DATE 10/19/04

GRADATION CURVES

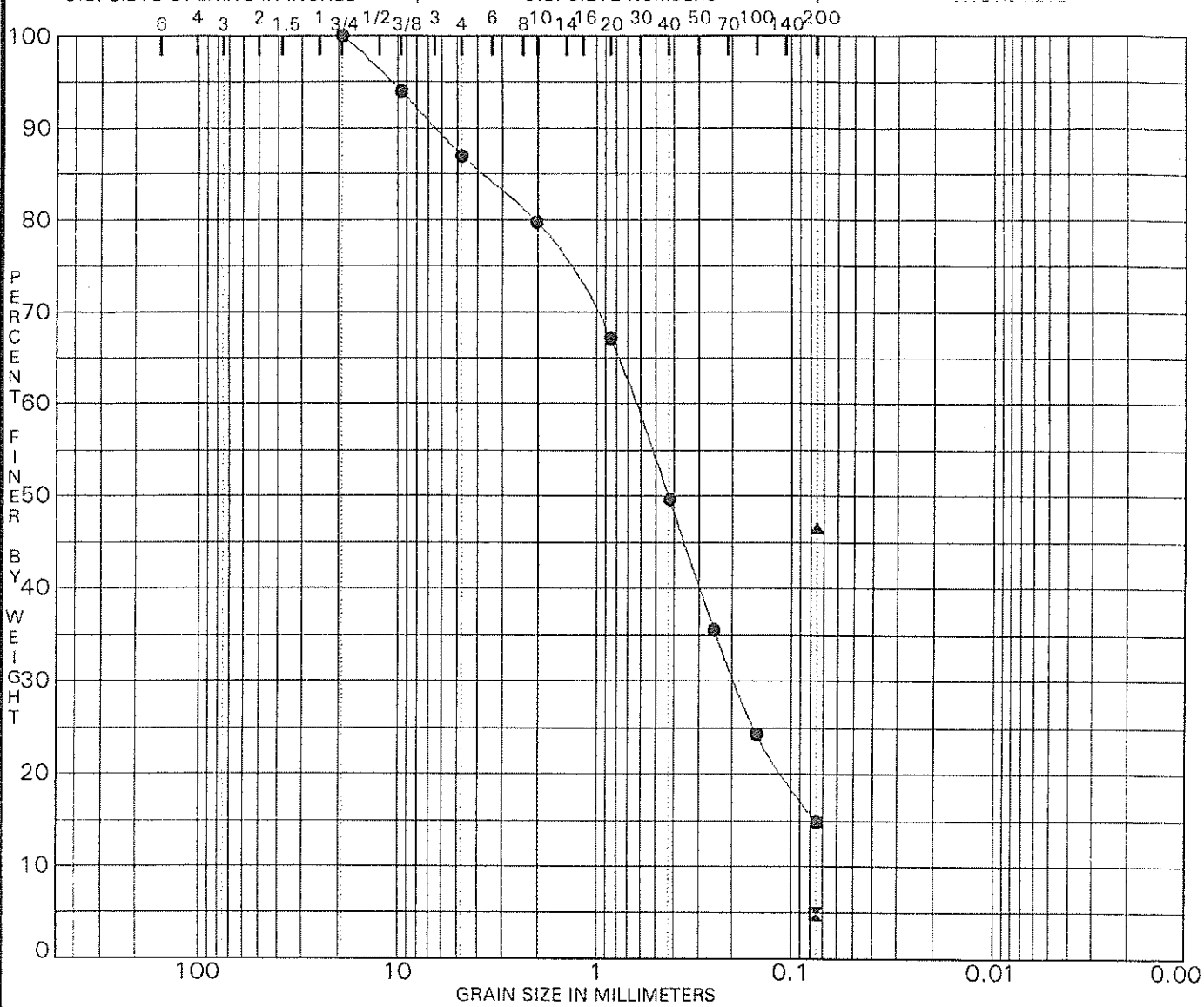

COBBLES	GRAVEL		SAND			SILT OR CLAY
	coarse	fine	coarse	medium	fine	

Specimen Identification			Classification
● GK-10	5.0		Light Brown Silty SAND with Gravel (SM)
☒ GK-10	15.0		Light Brown Sandy GRAVEL (GP)
▲ GK-10	30.0		Light Brown Clayey SAND (SC)

Specimen Identification	D100	D60	D30	D10	%Gravel	%Sand	%Silt	%Clay
● GK-10	19.00	0.64	0.194		13.1	72.0	14.9	
☒ GK-10							4.9	
▲ GK-10							46.5	

PROJECT Deboer

JOB NO. 1957
DATE 10/19/04

GRADATION CURVES

U.S. SIEVE OPENING IN INCHES

U.S. SIEVE NUMBERS

STYROMETER

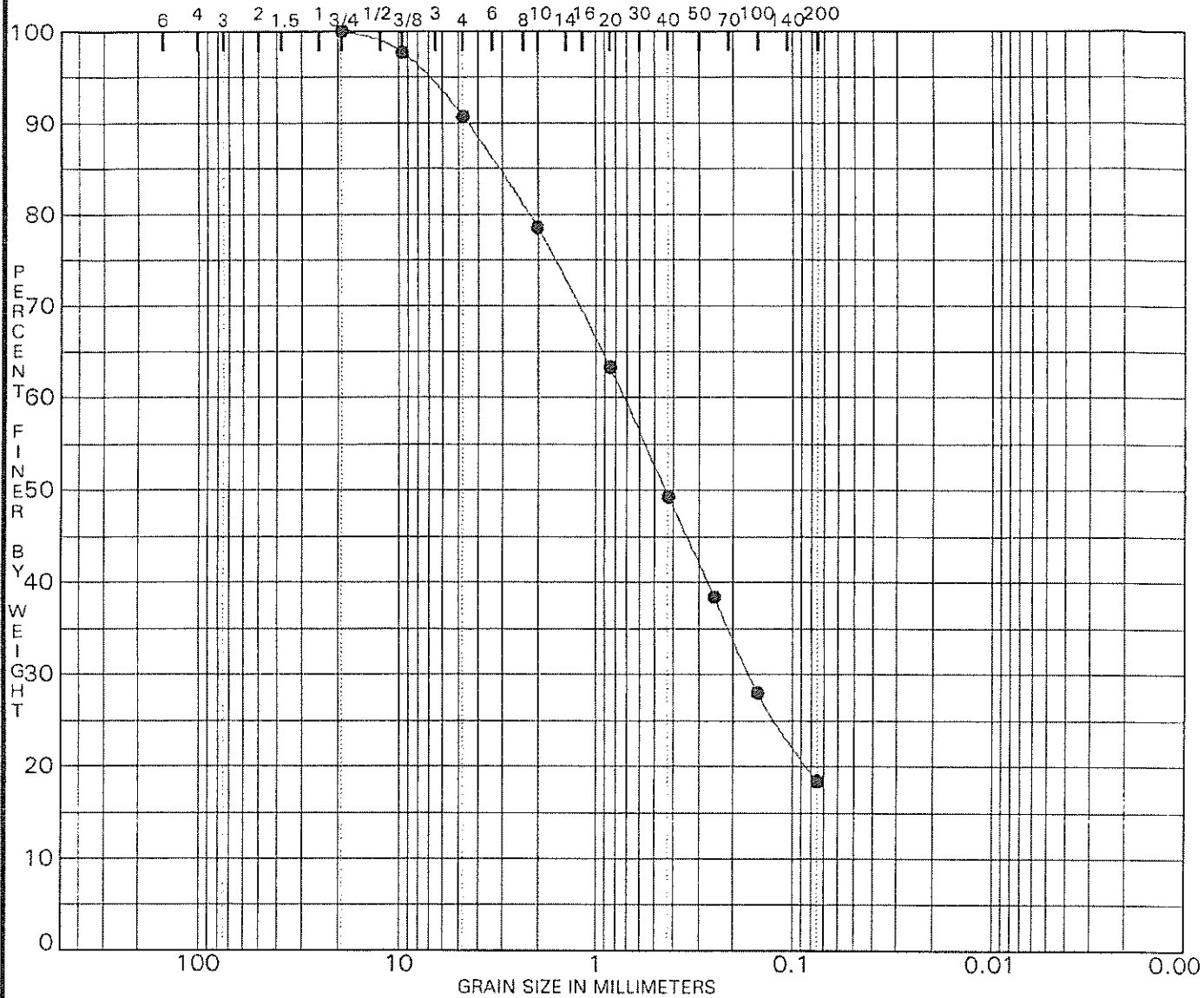

COBBLES	GRAVEL		SAND			SILT OR CLAY
	coarse	fine	coarse	medium	fine	

Specimen Identification		Classification							
●	GK-11 15.0	Brown Silty SAND (SM)							
Specimen Identification		D100	D60	D30	D10	%Gravel	%Sand	%Silt	%Clay
●	GK-11 15.0	19.00	0.72	0.166		9.3	72.3	18.4	

PROJECT Deboer

JOB NO. 1957
DATE 10/19/04

GRADATION CURVES

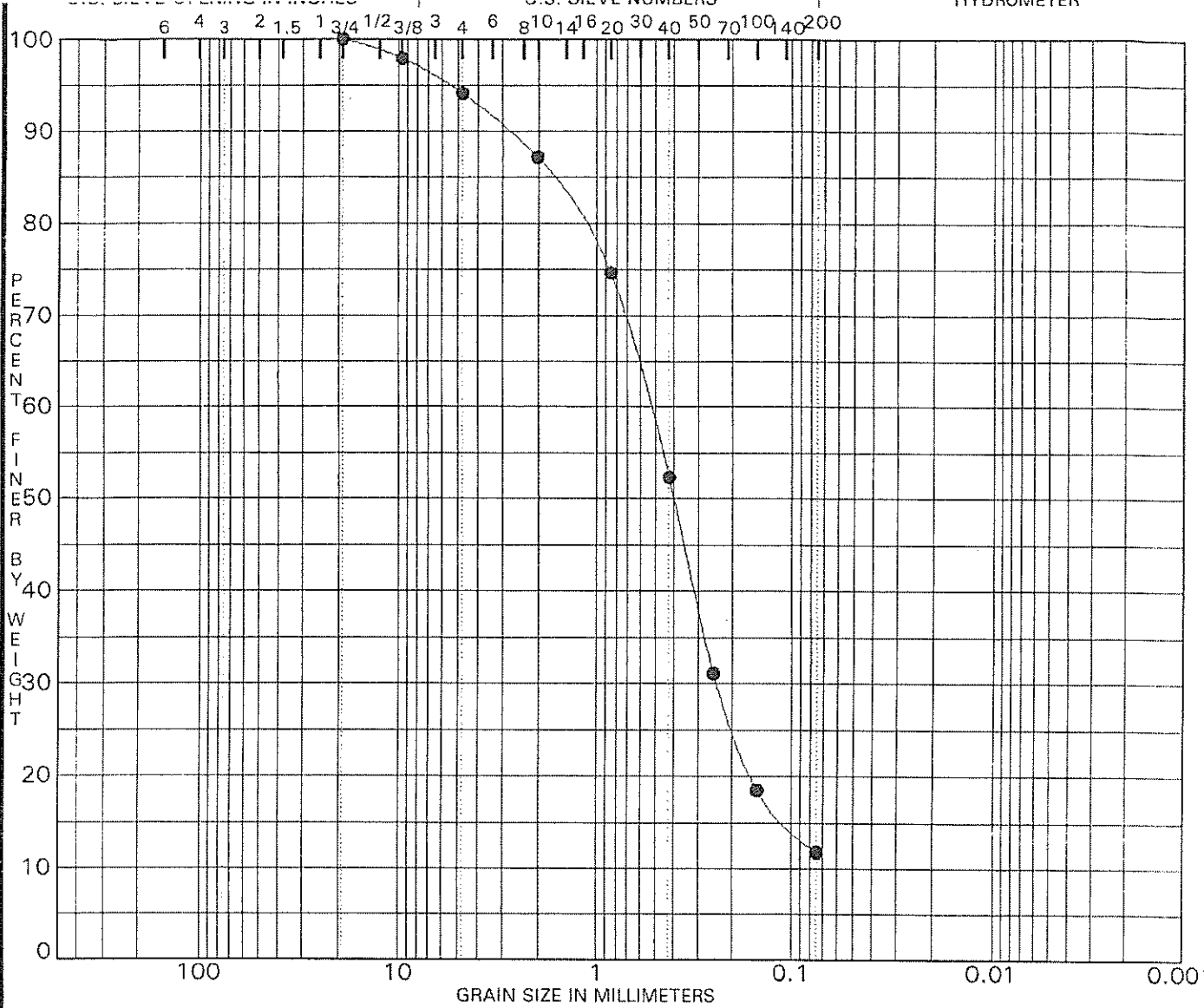

COBBLES	GRAVEL		SAND			SILT OR CLAY
	coarse	fine	coarse	medium	fine	

Specimen Identification			Classification					
●	GK-12	15.0	Grayish Brown Poorly Graded SAND with Silt (SP-SM)					

Specimen Identification	D100	D60	D30	D10	%Gravel	%Sand	%Silt	%Clay
● GK-12 15.0	19.00	0.54	0.239		5.9	82.3	11.8	

PROJECT Deboer JOB NO. 1957
 DATE 10/19/04

GRADATION CURVES

CONSOLIDATION TEST REPORT

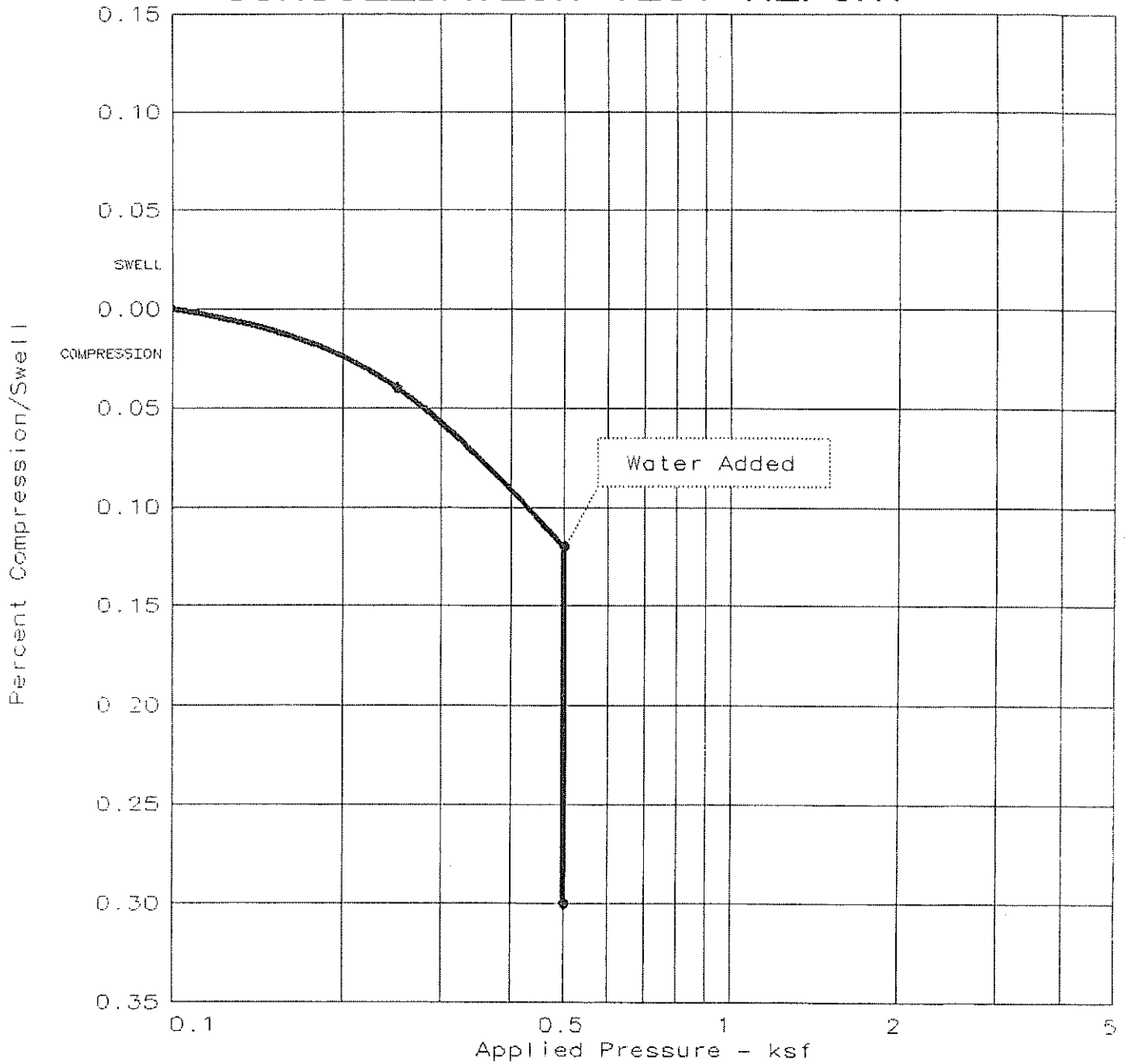

Clpse. %	Nat. Sat.	Nat. Moist.	Dry Density	LL	PI	Sp.Gr.	Initial void ratio
0.2	27.0 %	5.7	106.8	N/P	N/P	2.680	0.5665

TEST RESULTS	MATERIAL DESCRIPTION
Project No.: 1957 Project: Deboer Location: GK-1 @ 5.0 Ft. Date: 10-01-04	Brown Poorly Graded SAND Class: SP Remarks: Tested by: HVK Checked by: GDT
CONSOLIDATION TEST REPORT	Fig. No. De01

CONSOLIDATION TEST REPORT

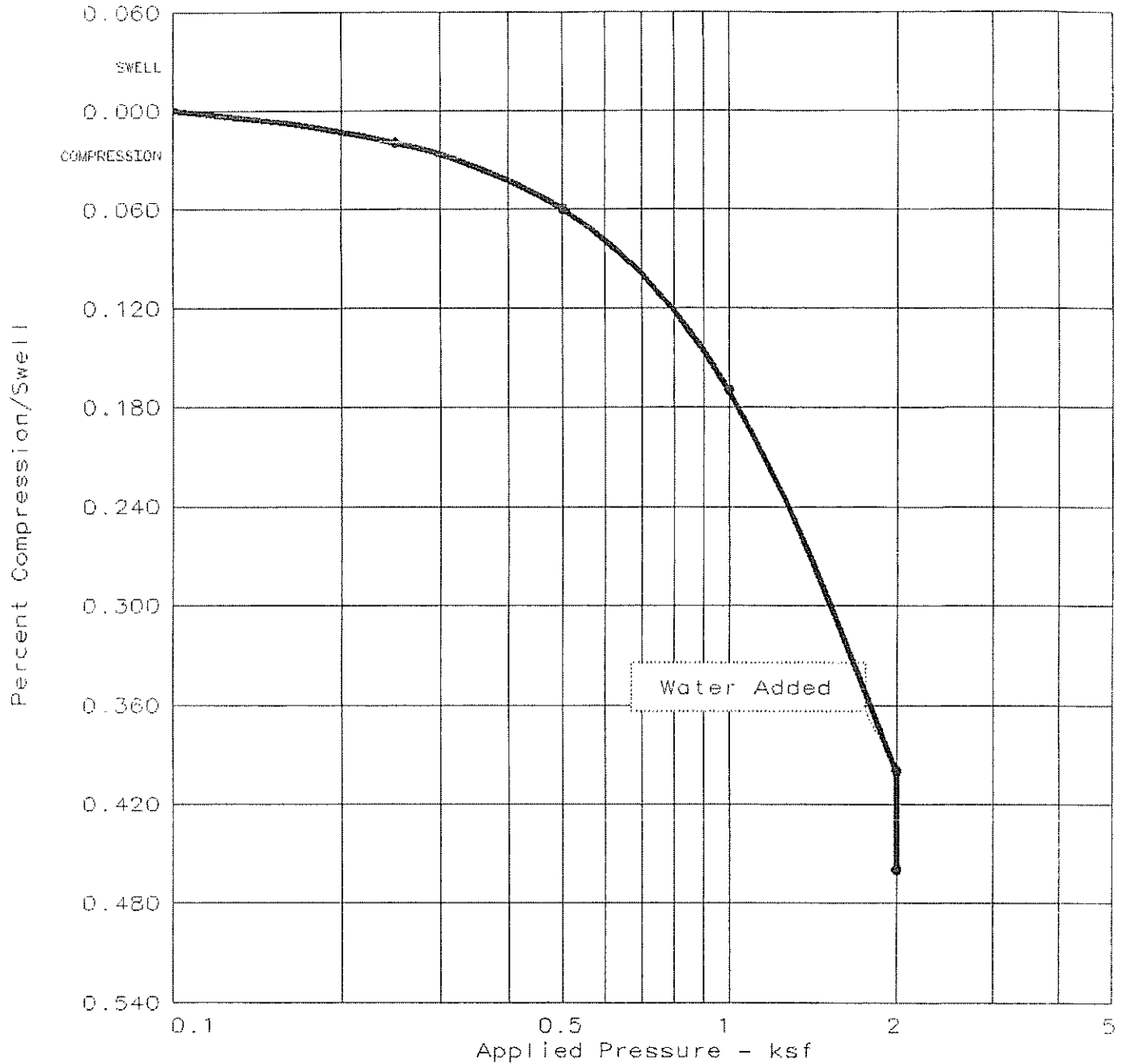

Clpse. %	Nat. Sat.	Nat. Moist.	Dry Density	LL	PI	Sp.Gr.	Initial void ratio
0.1	93.1 %	21.4	104.1	N/A	N/A	2.700	0.6195

TEST RESULTS	MATERIAL DESCRIPTION
Project No.: 1957 Project: Deboer Location: GK-2 @ 15.0 Ft. Date: 10-01-04	Brown Silty CLAY Class: CL Remarks: Tested by: HVK Checked by: GDT
CONSOLIDATION TEST REPORT	Fig. No. De02

CONSOLIDATION TEST REPORT

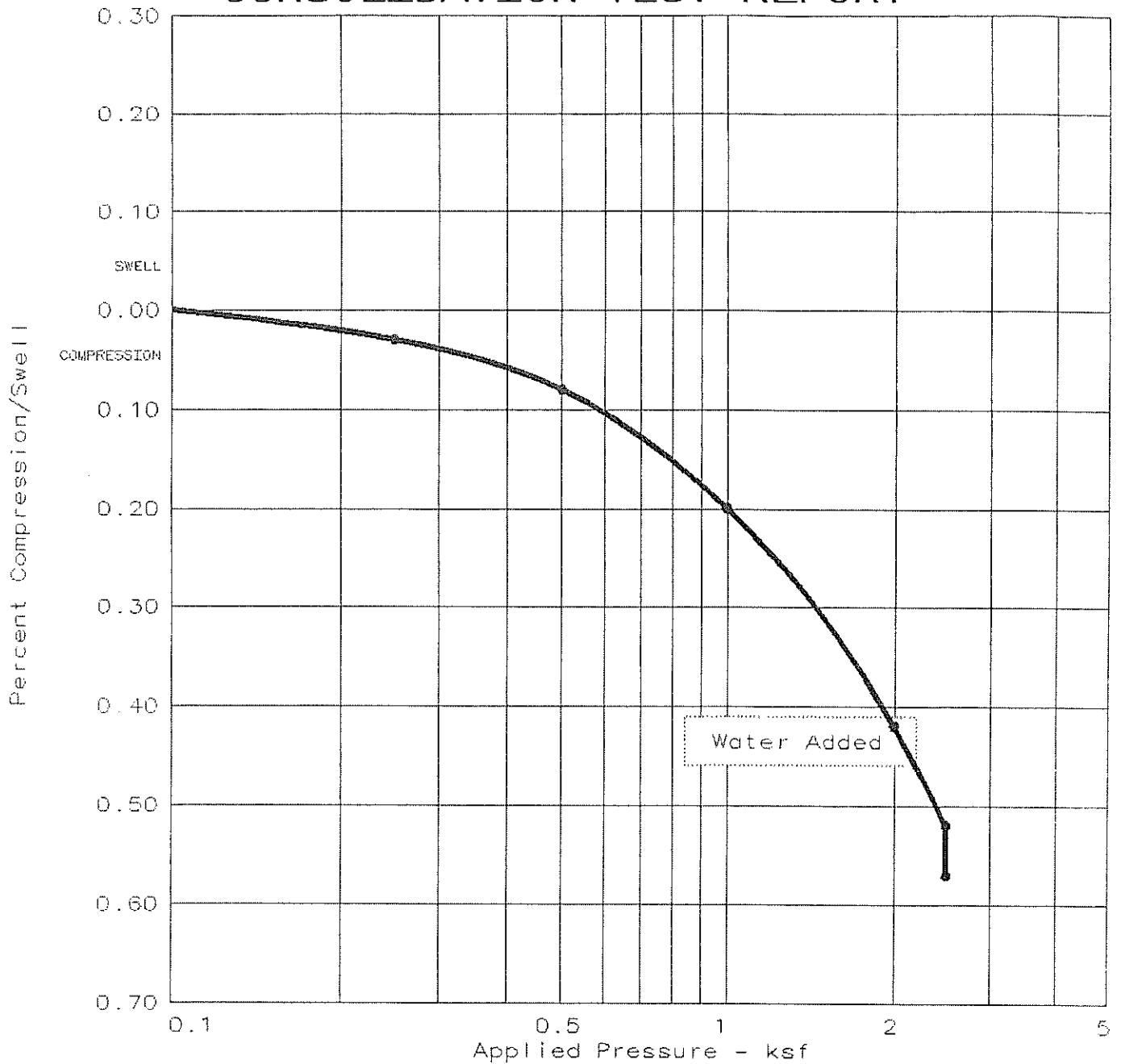

Clpse. %	Nat. Sat.	Nat. Moist.	Dry Density	LL	PI	Sp.Gr.	Initial void ratio
0.1	99.9 %	24.4	101.6	N/A	N/A	2.700	0.6585

TEST RESULTS	MATERIAL DESCRIPTION
	Brown Silty CLAY
	Class: CL
	Remarks:
	Tested by: HVK
	Checked by: GDT
CONSOLIDATION TEST REPORT	
	Fig. No. De03

CONSOLIDATION TEST REPORT

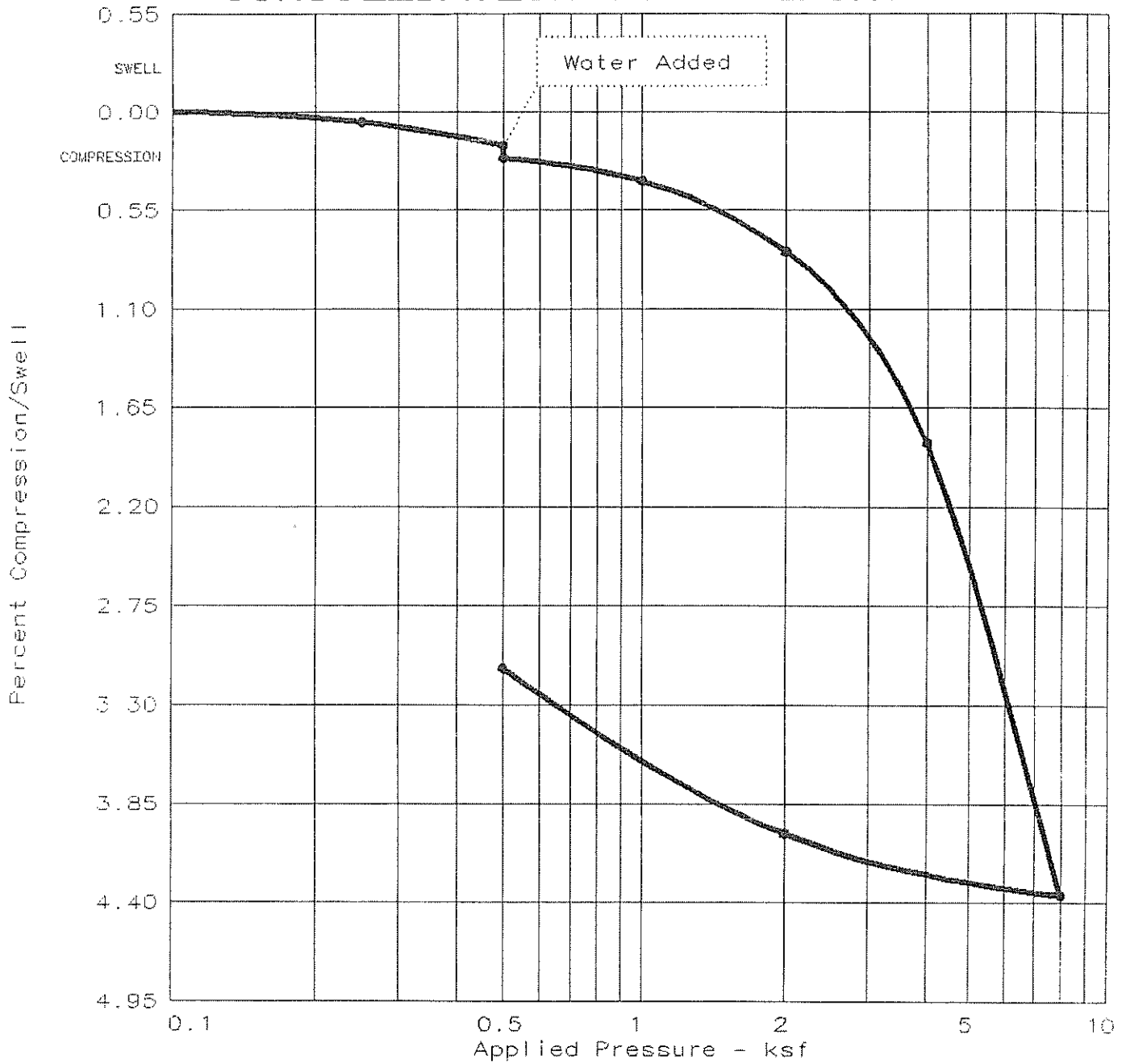

Clpse. %	Nat. Sat.	Nat. Moist.	Dry Density	LL	PI	Sp.Gr.	Initial void ratio
0.1	84.9 %	15.4	113.2	N/A	N/A	2.700	0.4887

TEST RESULTS	MATERIAL DESCRIPTION
Project No.: 1957 Project: Deboer Location: Gk-3 @ 5.0 Ft. Date: 10-10-04	Dark Brown Sandy CLAY Class: CL Remarks: Tested by: HVK Checked by: GDT
CONSOLIDATION TEST REPORT	Fig. No. _____

CONSOLIDATION TEST REPORT

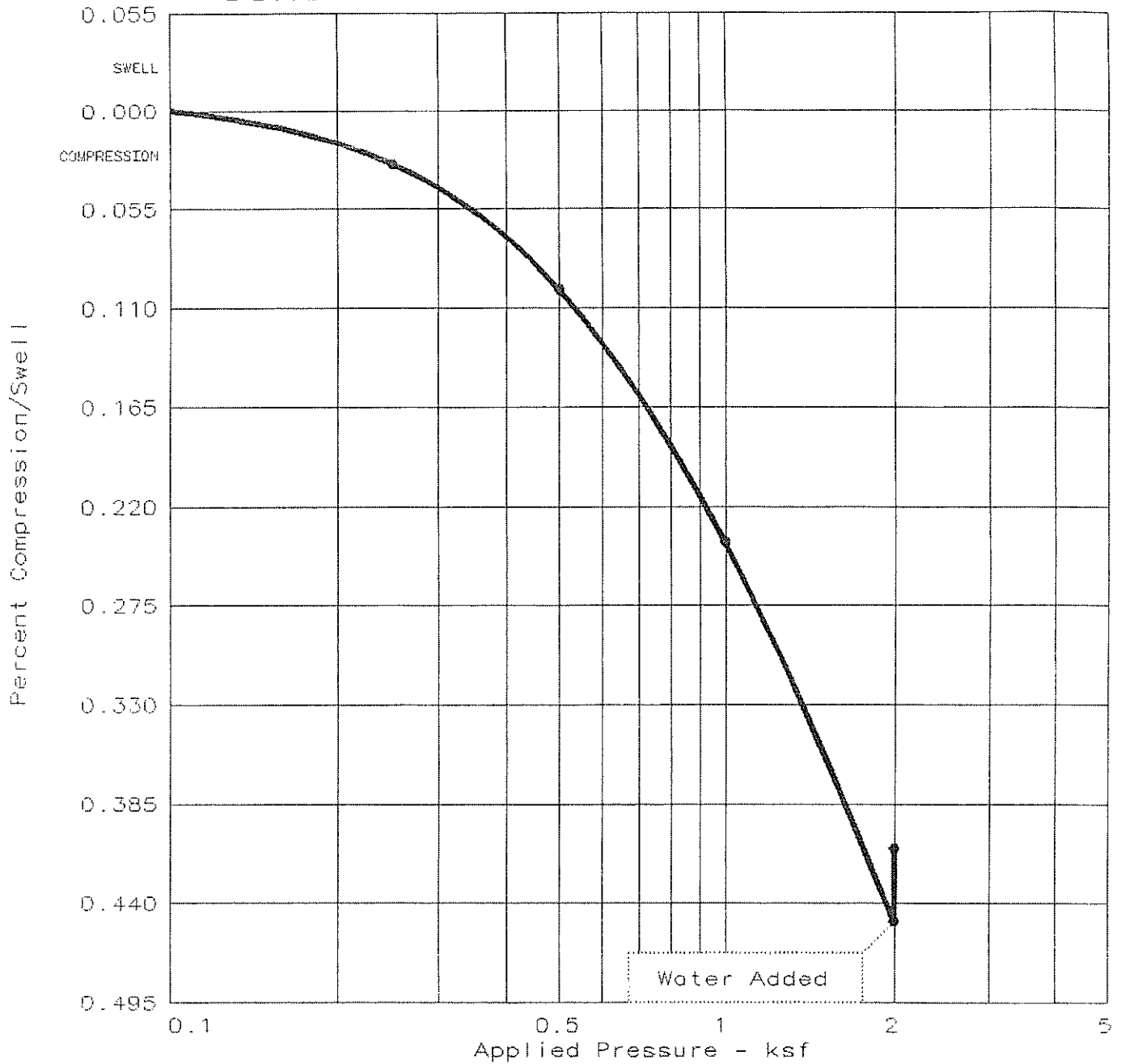

Natural Saturation	Natural Moisture	Dry Density	LL	PI	Sp.Gr.	Initial void ratio
56.3 %	11.8	107.5	N/A	N/A	2.700	0.5676

TEST RESULTS	MATERIAL DESCRIPTION
Percent swell = 0.1	Brown Sandy SILT
Project No.: 1957 Project: Deboer Location: GK-3 @ 15.0 Ft. Date: 10-01-04	Class: ML Remarks: Tested by: HVK Checked by: GDT
CONSOLIDATION TEST REPORT	Fig. No. De04

CONSOLIDATION TEST REPORT

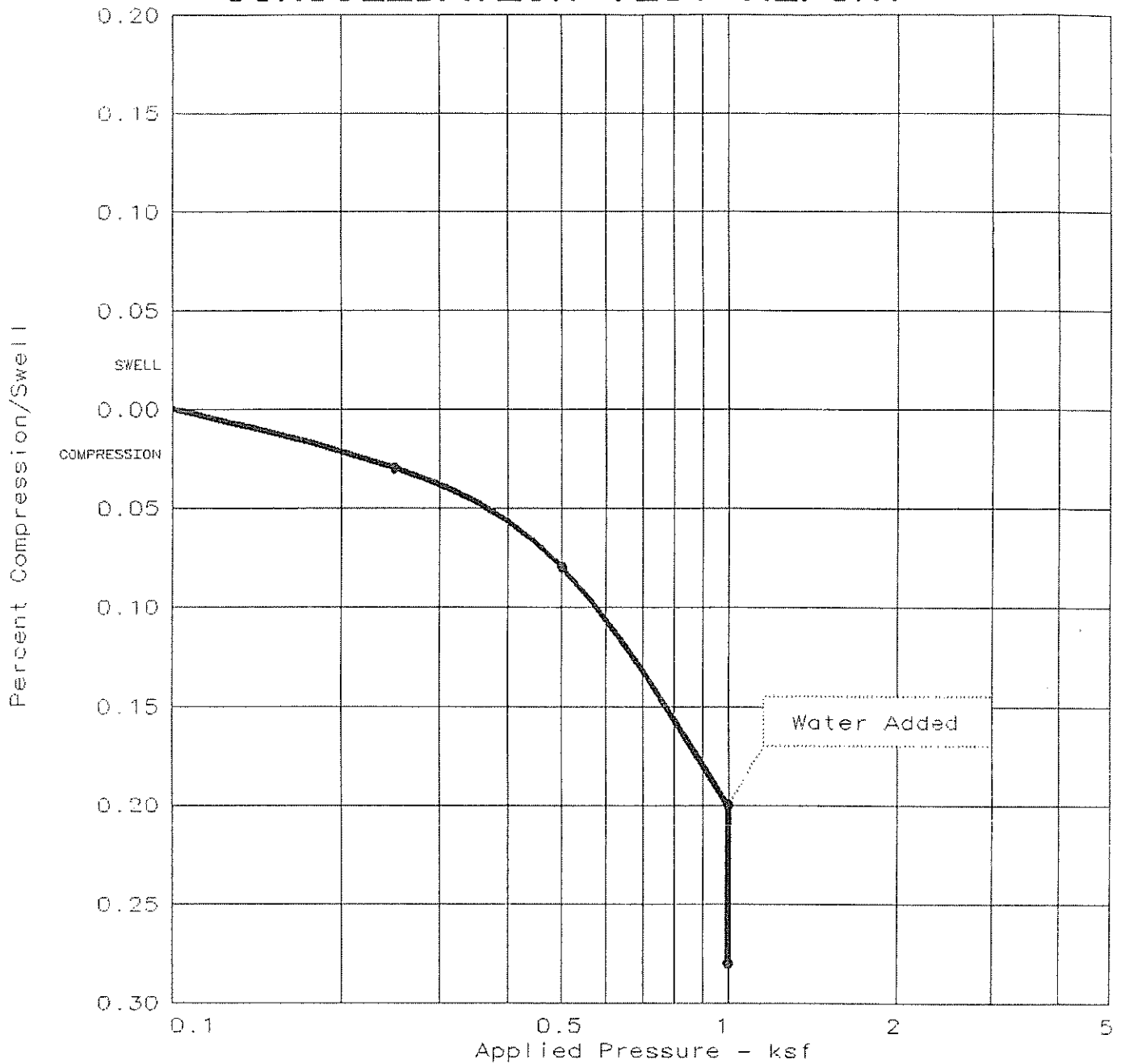

Clpse. %	Nat. Sat.	Nat. Moist.	Dry Density	LL	PI	Sp.Gr.	Initial void ratio
0.1	10.5 %	2.4	104.5	N/A	N/A	2.680	0.6015

TEST RESULTS	MATERIAL DESCRIPTION
Project No.: 1957 Project: Deboer Location: GK-4 @ 10.0 Ft. Date: 10-01-04	Brown Poorly Graded SAND Class: SP Remarks: Tested by: HVK Checked by: GDT
CONSOLIDATION TEST REPORT	Fig. No. De05

CONSOLIDATION TEST REPORT

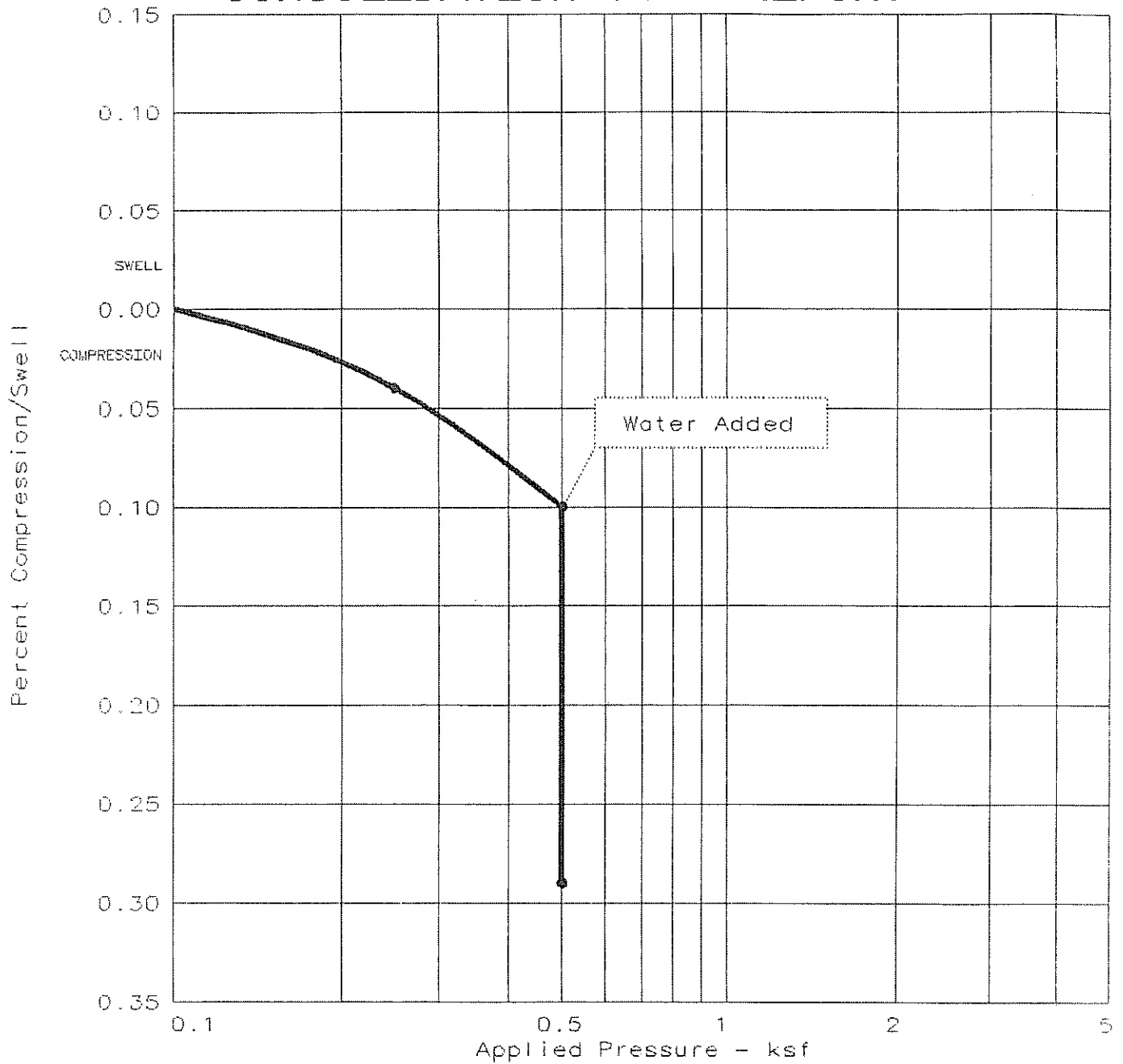

Clpse. %	Nat. Sat.	Nat. Moist.	Dry Density	LL	PI	Sp.Gr.	Initial void ratio
0.2	30.5 %	6.3	107.6	N/P	N/P	2.680	0.5550

TEST RESULTS	MATERIAL DESCRIPTION
Project No.: 1957 Project: Deboer Location: GK-6 @ 5.0 Ft. Date: 10-01-04	Brown Silty SAND Class: SM Remarks: Tested by: HVK Checked by: GDT
CONSOLIDATION TEST REPORT	Fig. No. De06

CONSOLIDATION TEST REPORT

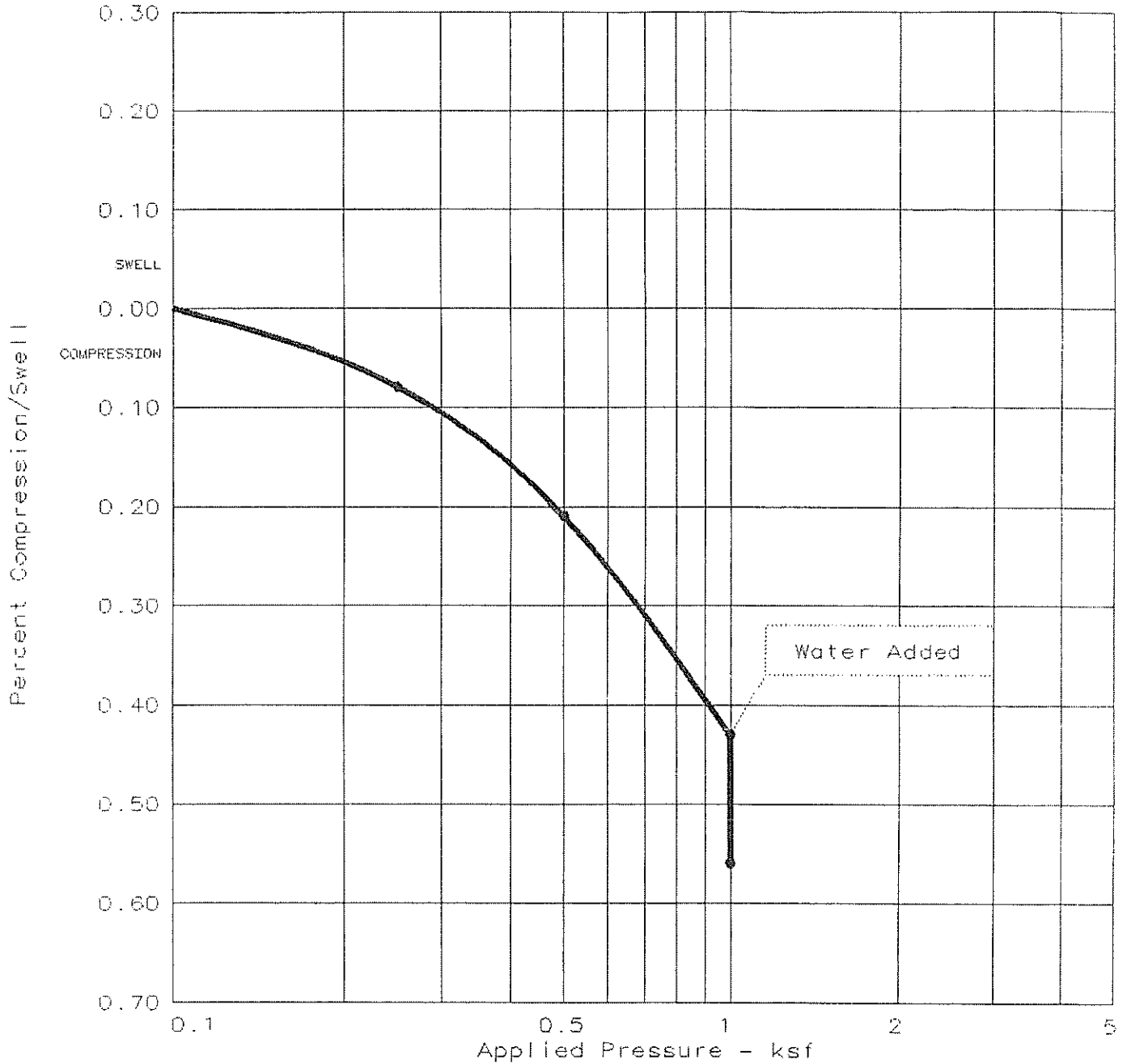

Clpse. %	Nat. Sat.	Nat. Moist.	Dry Density	LL	PI	Sp.Gr.	Initial void ratio
0.2	97.5 %	20.7	107.1	N/A	N/A	2.700	0.5739

TEST RESULTS	MATERIAL DESCRIPTION
Project No.: 1957 Project: . Deboer Location: GK-7 @ 10.0 Ft. Date: 10-05-04	Dark Brown Sandy SILT Class: ML Remarks: Tested by: HVK Checked by: GDT
CONSOLIDATION TEST REPORT	Fig. No. De07

CONSOLIDATION TEST REPORT

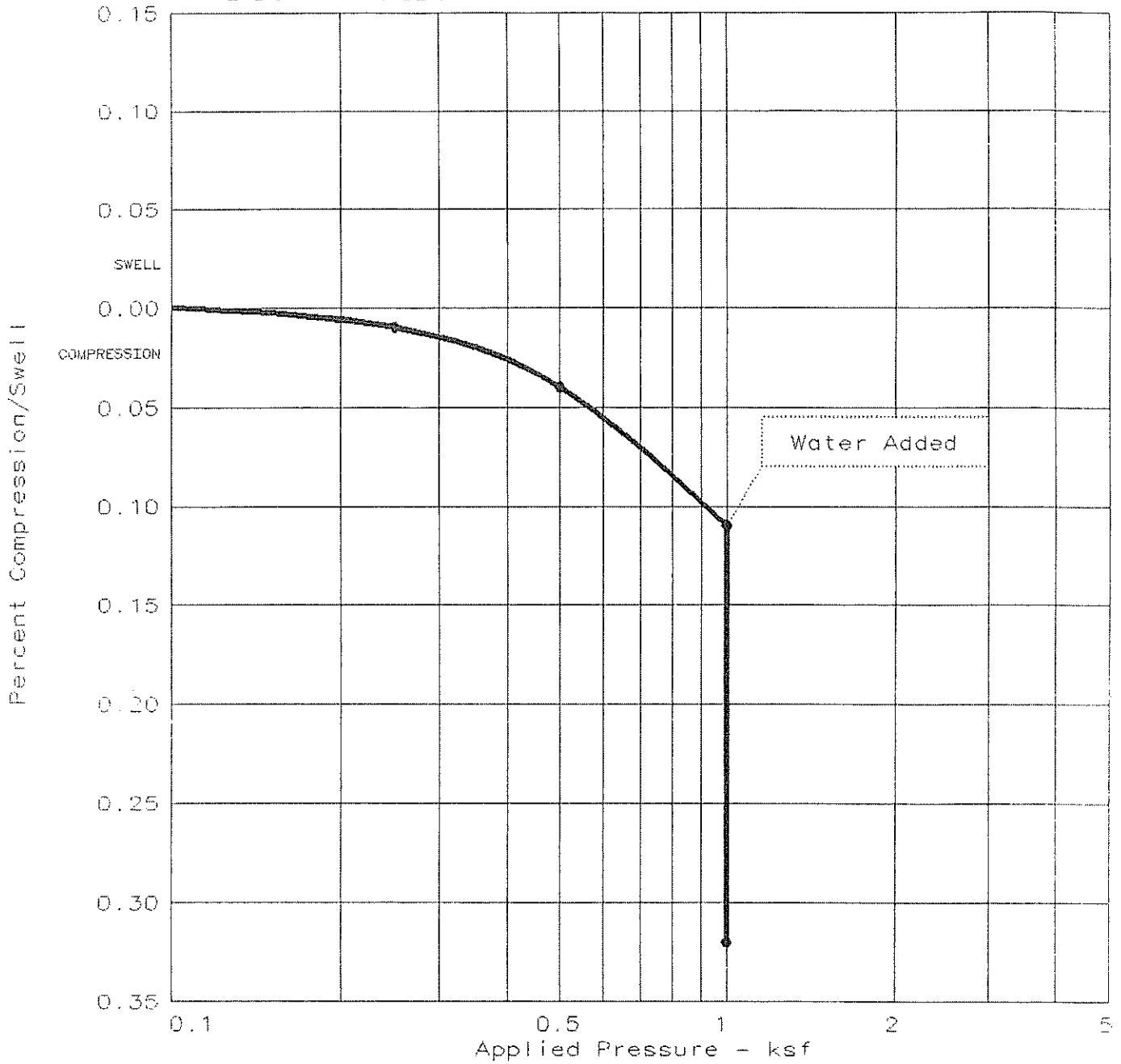

Clpse. %	Nat. Sat.	Nat. Moist.	Dry Density	LL	PI	Sp.Gr.	Initial void ratio
0.2	20.1 %	2.9	121.0	N/P	N/P	2.680	0.3825

TEST RESULTS	MATERIAL DESCRIPTION
Project No.: 1957 Project: Deboer Location: GK-10 @ 5.0 Ft. Date: 10-05-04	Light Brown Silty SAND Class: SM Remarks: Tested by: HVK Checked by: HVK
CONSOLIDATION TEST REPORT	Fig. No. De08

CONSOLIDATION TEST REPORT

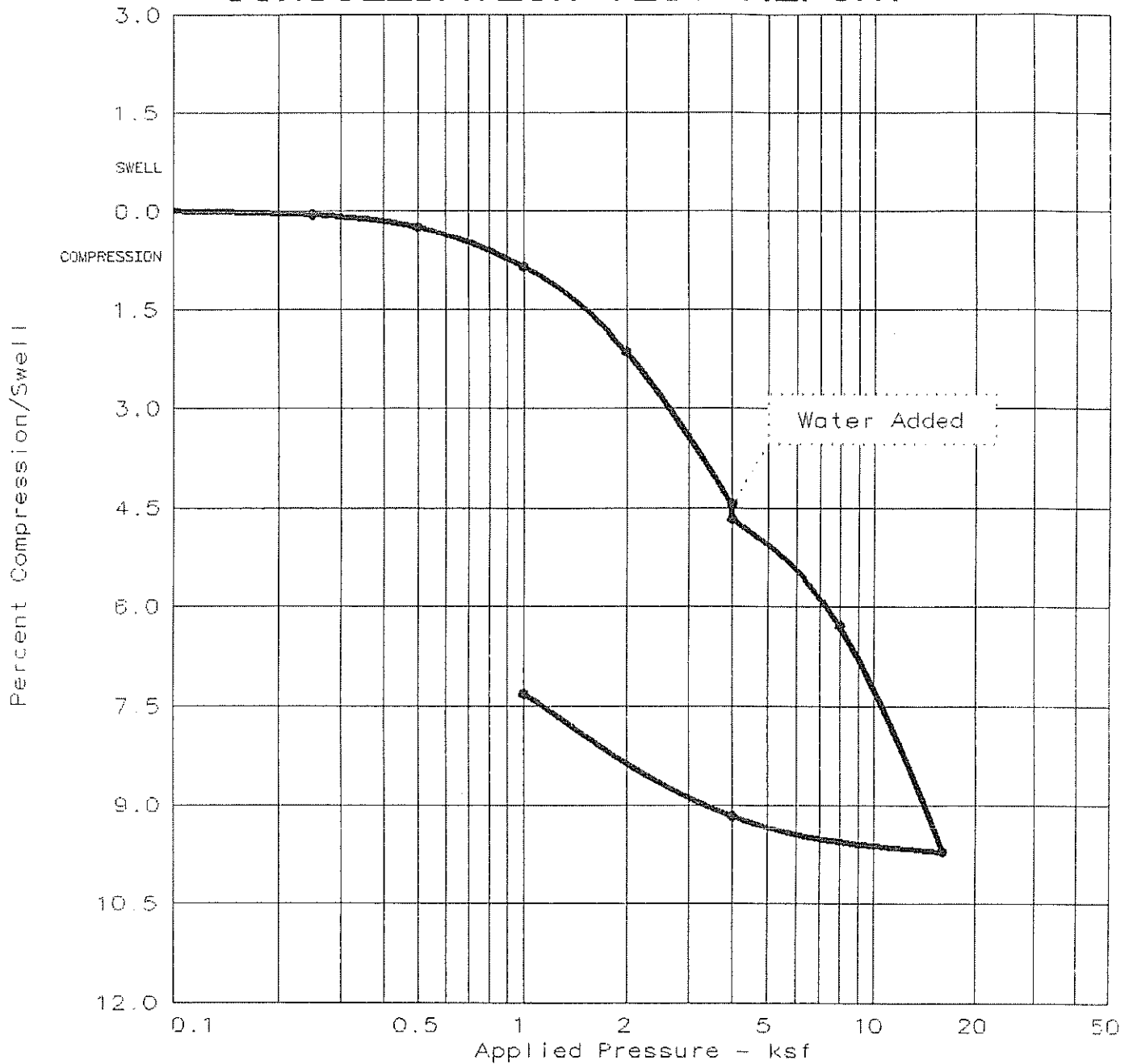

Clpse. %	Nat. Sat.	Nat. Moist.	Dry Density	LL	PI	Sp.Gr.	Initial void ratio
0.2	98.9 %	19.8	109.4	N/A	N/A	2.700	0.5406

TEST RESULTS	MATERIAL DESCRIPTION
	Light Brown Clayey SAND
	Class: SC
	Remarks:
	Tested by: HVK
	Checked by: GDT
CONSOLIDATION TEST REPORT	Fig. No. <u>1</u>

CONSOLIDATION TEST REPORT

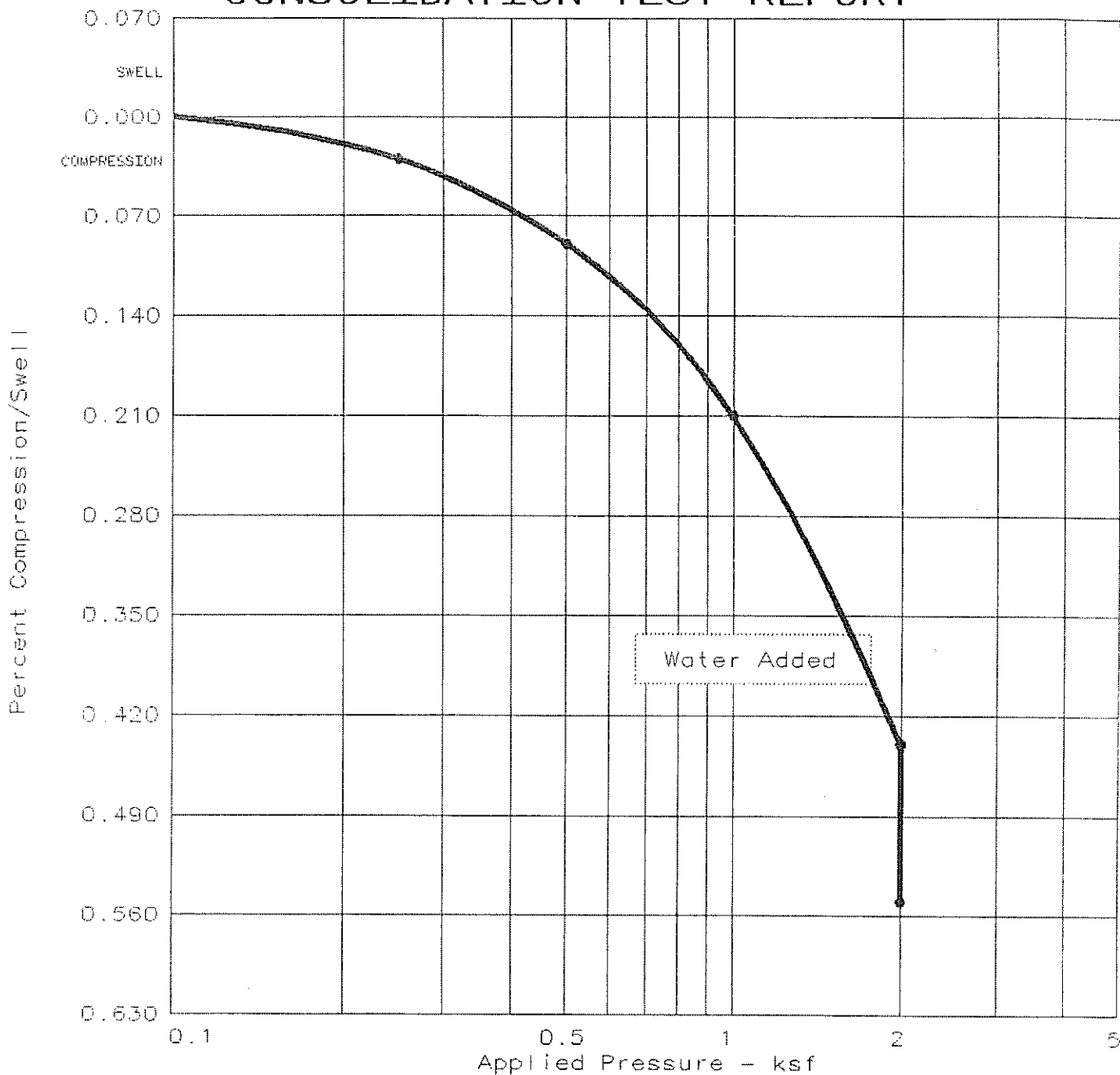

Clpse. %	Nat. Sat.	Nat. Moist.	Dry Density	LL	PI	Sp.Gr.	Initial void ratio
0.2	42.0 %	5.0	126.6	N/P	N/P	2.680	0.3211

TEST RESULTS	MATERIAL DESCRIPTION
Project No.: 1957 Project: Deboer Location: GK-11 @ 15.0 Ft. Date: 10-05-04	Brown Silty SAND (SM) Class: SM Remarks: Tested by: HVK Checked by: GDT
CONSOLIDATION TEST REPORT	Fig. No. _____

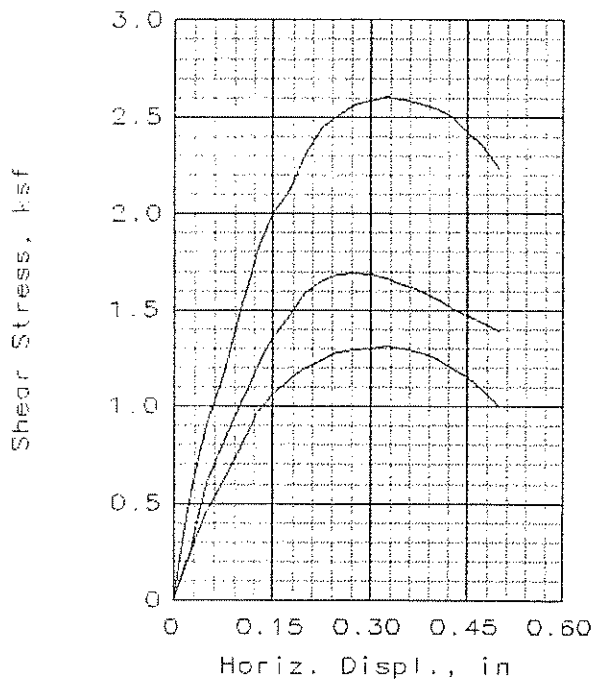
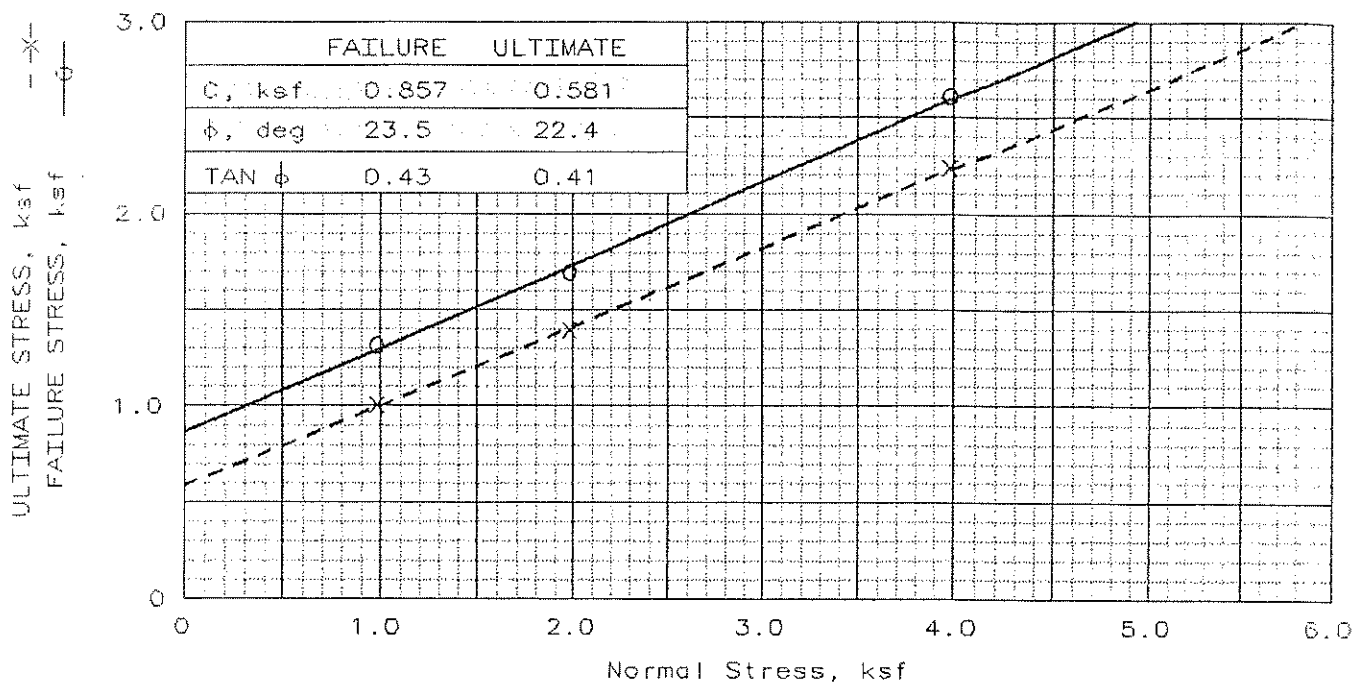

	1	2	3	
INITIAL	WATER CONTENT, %	12.4	12.4	12.4
	DRY DENSITY, pcf	115.8	115.8	115.8
	SATURATION, %	73.8	73.8	73.8
	VOID RATIO	0.455	0.455	0.455
	DIAMETER, in	2.420	2.420	2.420
	HEIGHT, in	2.000	2.000	2.000
AT TEST	WATER CONTENT, %	16.1	16.1	15.5
	DRY DENSITY, pcf	116.9	117.2	118.6
	SATURATION, %	98.4	99.2	99.3
	VOID RATIO	0.442	0.438	0.421
	DIAMETER, in	2.420	2.420	2.420
	HEIGHT, in	1.982	1.977	1.954
NORMAL STRESS, ksf	1.000	2.000	4.000	
FAILURE STRESS, ksf	1.312	1.693	2.605	
DISPLACEMENT, in	0.325	0.275	0.325	
ULTIMATE STRESS, ksf	1.002	1.393	2.234	
DISPLACEMENT, in	0.500	0.500	0.500	
Strain rate, in/min	0.00750	0.00750	0.0075	

SAMPLE TYPE: Undisturbed
 DESCRIPTION: Brown Sandy CLAY
 (CL)
 SPECIFIC GRAVITY= 2.7
 REMARKS:

CLIENT:
 PROJECT: -Deboer
 SAMPLE LOCATION: GK-8 @ 10.0 Ft.
 PROJ. NO.: 1957 DATE: 10-12-04

DIRECT SHEAR TEST REPORT

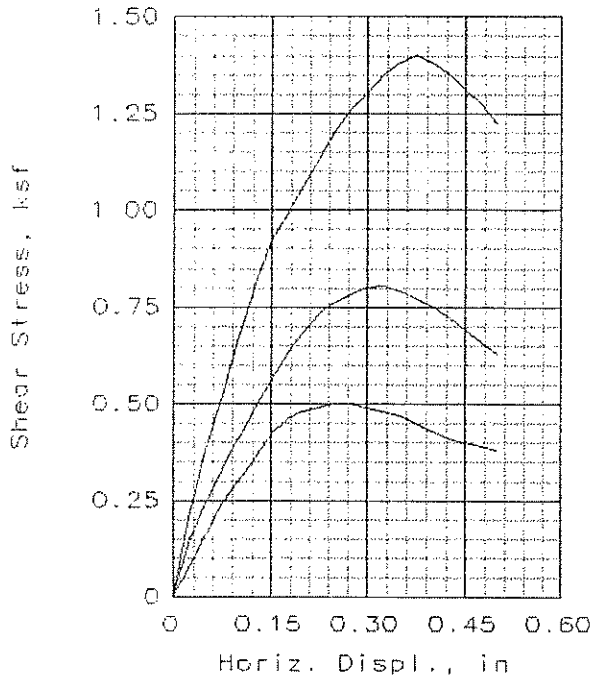
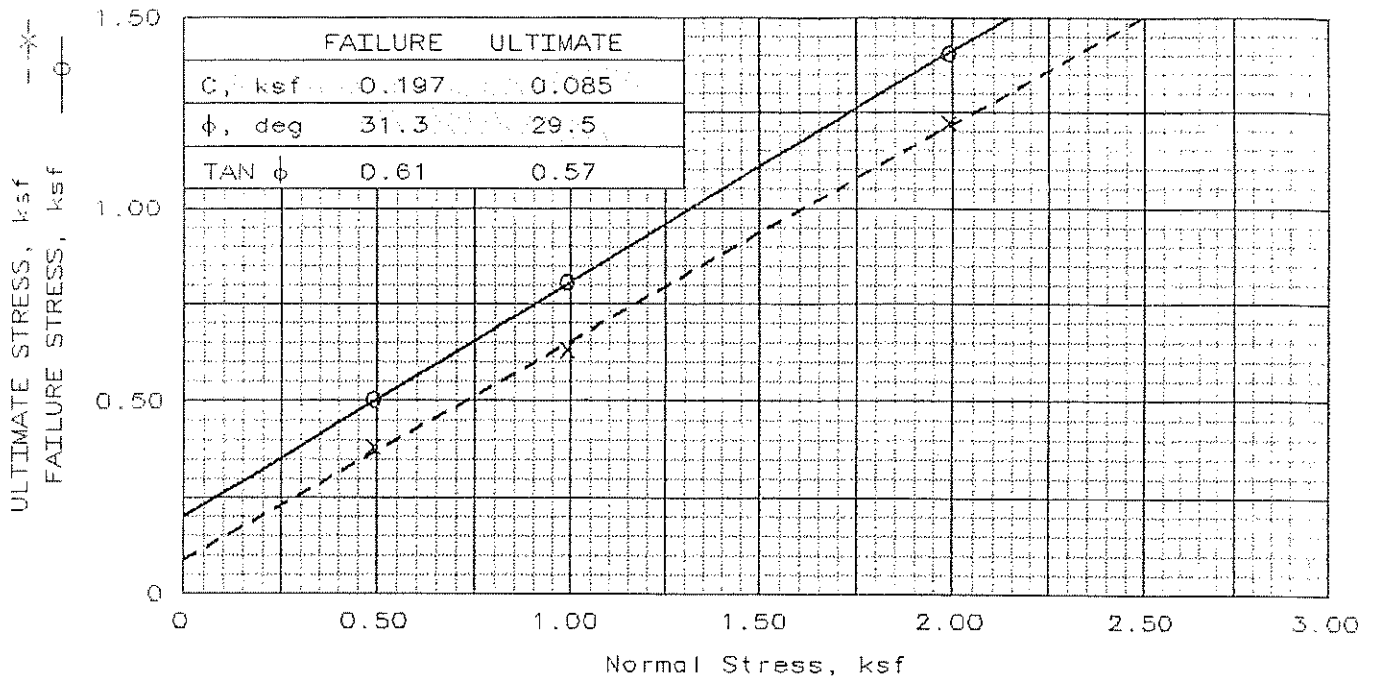

	1	2	3	
INITIAL	WATER CONTENT, %	9.3	9.3	9.3
	DRY DENSITY, pcf	106.9	107.0	107.0
	SATURATION, %	43.9	43.7	43.7
	VOID RATIO	0.565	0.569	0.570
	DIAMETER, in	2.420	2.420	2.420
	HEIGHT, in	2.000	2.000	2.000
AT TEST	WATER CONTENT, %	19.5	19.4	18.1
	DRY DENSITY, pcf	107.8	109.3	112.3
	SATURATION, %	94.6	97.4	98.5
	VOID RATIO	0.552	0.536	0.495
	DIAMETER, in	2.420	2.420	2.420
	HEIGHT, in	1.984	1.958	1.905
NORMAL STRESS, ksf	0.500	1.000	2.000	
FAILURE STRESS, ksf	0.501	0.804	1.403	
DISPLACEMENT, in	0.250	0.325	0.375	
ULTIMATE STRESS, ksf	0.381	0.631	1.222	
DISPLACEMENT, in	0.500	0.500	0.500	
Strain rate, in/min	0.00750	0.00750	0.0075	

SAMPLE TYPE: Undisturbed
 DESCRIPTION: Dark Gray Silty
 SAND (SM)
 SPECIFIC GRAVITY= 2.68
 REMARKS:

CLIENT:
 PROJECT: -Deboer
 SAMPLE LOCATION: GK-5 @ 5.0 Ft.
 PROJ. NO.: 1957 DATE: 10-12-04

DIRECT SHEAR TEST REPORT

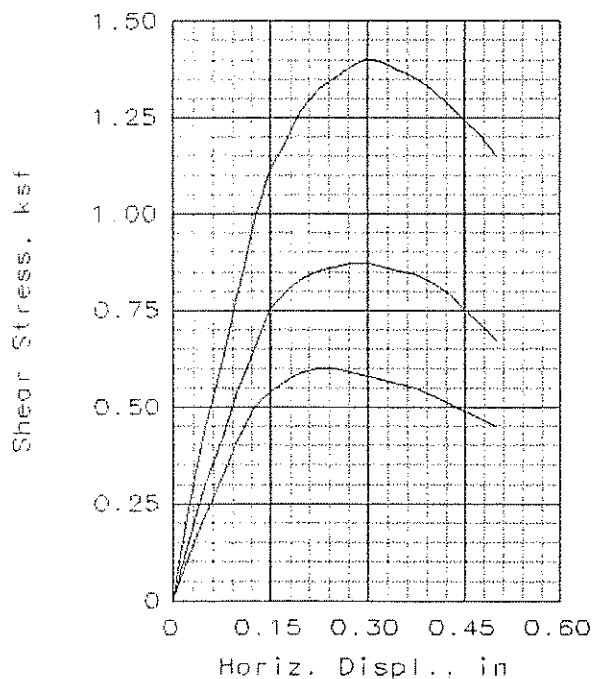
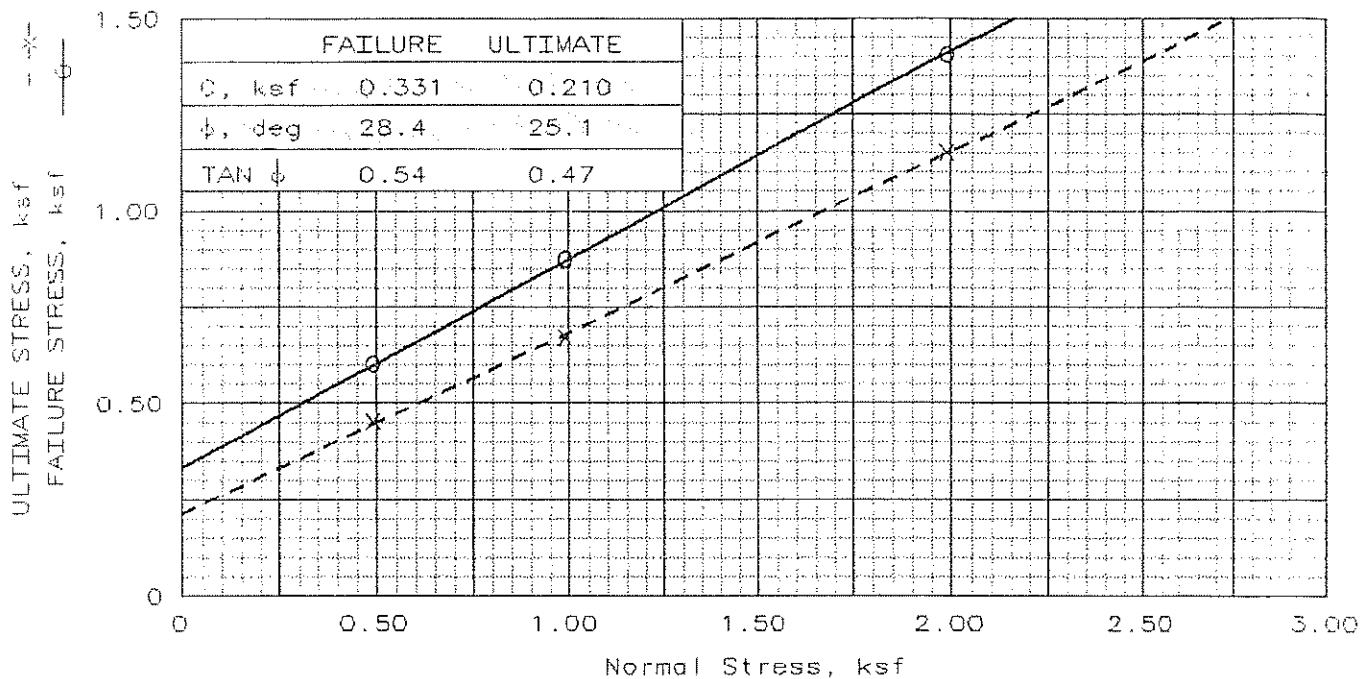

	1	2	3	
INITIAL	WATER CONTENT, %	11.1	11.1	11.1
	DRY DENSITY, pcf	119.9	119.7	119.9
	SATURATION, %	74.4	74.1	74.3
	VOID RATIO	0.401	0.402	0.401
	DIAMETER, in	2.420	2.420	2.420
	HEIGHT, in	2.000	2.000	2.000
AT TEST	WATER CONTENT, %	14.0	14.2	13.7
	DRY DENSITY, pcf	120.8	121.0	122.4
	SATURATION, %	96.3	98.3	99.1
	VOID RATIO	0.390	0.388	0.372
	DIAMETER, in	2.420	2.420	2.420
	HEIGHT, in	1.985	1.979	1.958
NORMAL STRESS, ksf	0.500	1.000	2.000	
FAILURE STRESS, ksf	0.601	0.872	1.403	
DISPLACEMENT, in	0.225	0.275	0.300	
ULTIMATE STRESS, ksf	0.451	0.671	1.152	
DISPLACEMENT, in	0.500	0.500	0.500	
Strain rate, in/min	0.00750	0.00750	0.0075	

SAMPLE TYPE: Undisturbed
 DESCRIPTION: Dark Brown Clayey SAND (SC)

SPECIFIC GRAVITY= 2.69

REMARKS:

CLIENT:

PROJECT: Deboer

SAMPLE LOCATION: GK-3 @ 10.0 Ft.

PROJ. NO.: 1957

DATE: 10-06-04

DIRECT SHEAR TEST REPORT

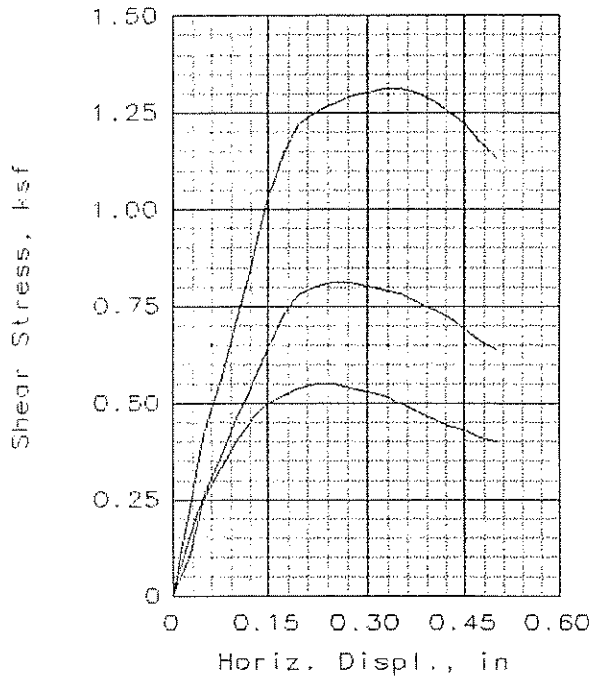
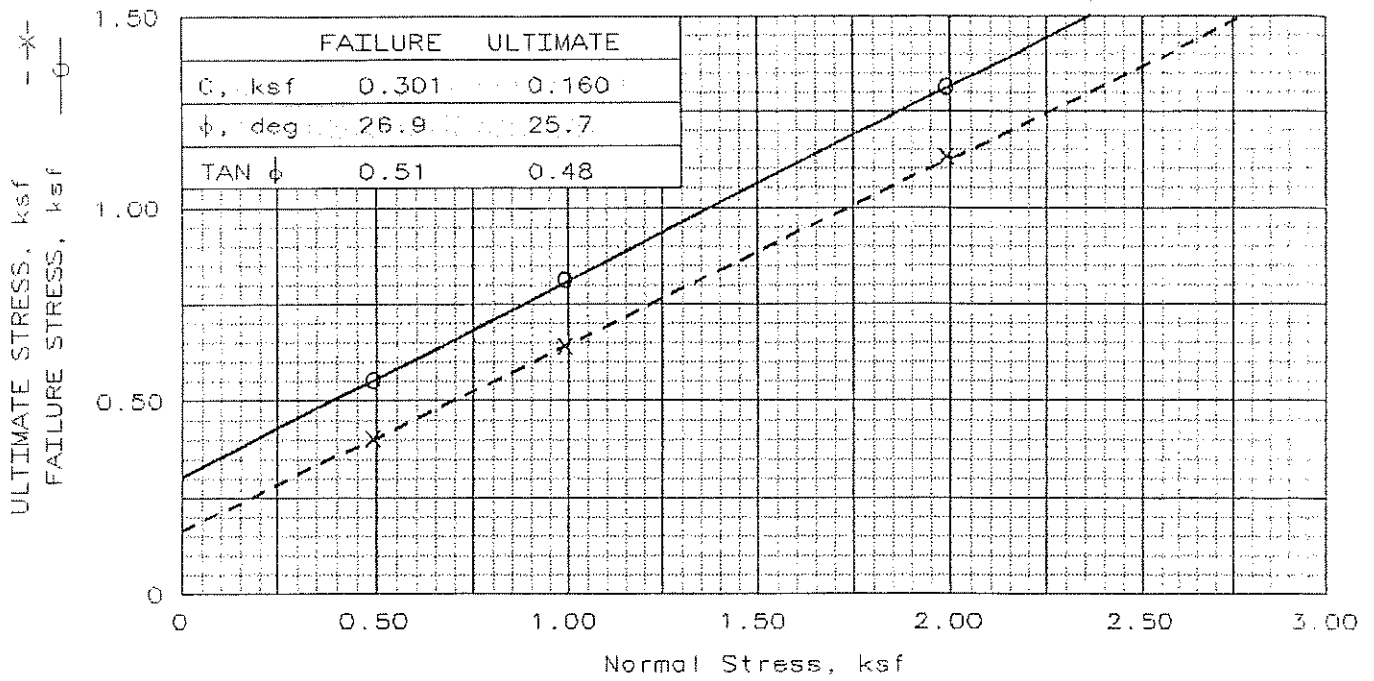

	1	2	3	
INITIAL	WATER CONTENT, %	14.4	14.4	14.4
	DRY DENSITY, pcf	111.7	111.7	111.7
	SATURATION, %	76.7	76.6	76.7
	VOID RATIO	0.508	0.509	0.505
	DIAMETER, in	2.420	2.420	2.420
	HEIGHT, in	2.000	2.000	2.000
AT TEST	WATER CONTENT, %	17.3	18.0	17.1
	DRY DENSITY, pcf	112.6	112.7	113.0
	SATURATION, %	93.9	98.0	94.0
	VOID RATIO	0.497	0.495	0.491
	DIAMETER, in	2.420	2.420	2.420
	HEIGHT, in	1.985	1.982	1.978
NORMAL STRESS, ksf	0.500	1.000	2.000	
FAILURE STRESS, ksf	0.551	0.811	1.312	
DISPLACEMENT, in	0.225	0.250	0.325	
ULTIMATE STRESS, ksf	0.401	0.641	1.132	
DISPLACEMENT, in	0.500	0.500	0.500	
Strain rate, in/min	0.00750	0.00750	0.0075	

SAMPLE TYPE: Undisturbed
 DESCRIPTION: Light Brown Silty SAND with Clay (SM/SC)
 SPECIFIC GRAVITY= 2.7
 REMARKS:

CLIENT:
 PROJECT: Deboer
 SAMPLE LOCATION: GK-2 @ 5.0 Ft.
 PROJ. NO.: 1957 DATE: 10-05-04

DIRECT SHEAR TEST REPORT

ANAHEIM TEST LABORATORY

3008 S. ORANGE AVENUE
SANTA ANA, CALIFORNIA 92707
PHONE (714) 549-7267

GEO KINETICS:
15510 ROCKFIELD BLVD. #C3
IRVINE, CA. 92618

DATE: 10/05/04

P.O. No. VERBAL

Shipper No.

Lab. No. A-5855-1

Specification:

Material: SOIL

ATTN: GLENN

PROJECT: DEBOER

GK-5 @ 0-5'
BULK

ANALYTICAL REPORT

CORROSION SERIES SUMMARY OF DATA

pH	SOLUBLE SULFATES per CA. 417 ppm	SOLUBLE CHLORIDES per CA. 422 ppm	MIN. RESISTIVITY per CA. 643 ohm-cm
6.8	132	69	730

RESPECTFULLY SUBMITTED

POPPY BRIDGER Chief Chemist

"R" VALUE CA 301

Client: GEO KINETICS:

Job No.: A 5855-2 Date: 10/7/2004

Client Reference No DEBOER

Soil Type: Gray, F.M Silty Sand

TEST SPECIMEN		A	B	C	D
Compactor Air Pressure	psi	200	300	250	
Initial Moisture Content	%	10.6	10.6	10.6	
Moisture at Compaction	%	13.4	12.4	12.9	
Briquette Height	in.	2.50	2.54	2.51	
Dry Density	pcf	109.0	111.1	109.7	
EXUDATION PRESSURE	psi	247	630	415	
EXPANSION dial	(x .0001)	2	10	8	
Ph at 1000 pounds	psi	27	19	23	
Ph at 2000 pounds	psi	43	32	38	
Displacement	turns	4.5	4.17	4.3	
"R" Value		60	71	65	
CORRECTED "R" VALUE		60	71	65	

Final "R" Value	
BY EXUDATION: @ 300 psi	62
BY EXPANSION: TI = 5.0	65

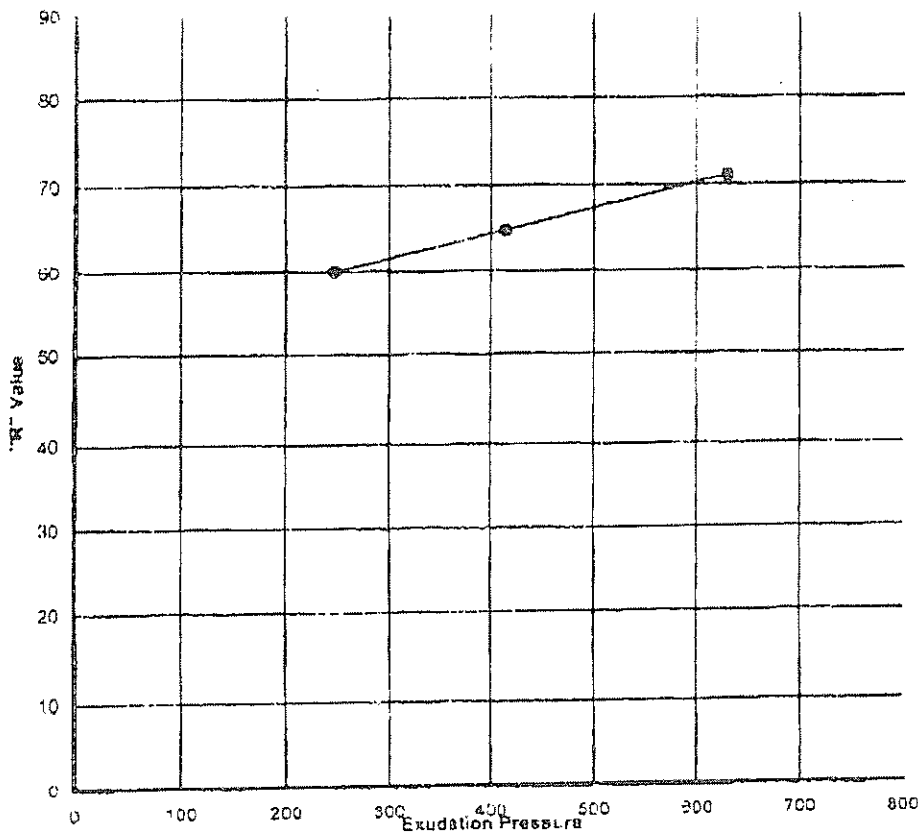

**Table 2 - DeBoer Moisture & Organic
Soil Testing Results**

LOCATION	DEPTH (ft.)	MOISTURE CONTENT %	ORGANIC CONTENT %
HA -1	0-6"	8.4	0.41
	1-1.5'	9.6	0.52
	3-3.5'	13.6	0.23
HA -2	0-6"	8.5	0.55
	1-1.5'	10.8	0.72
	3-3.5'	13.2	0.48
HA -3	0-6"	8.4	0.24
	1-1.5'	8.8	0.24
	3-3.5'	7.0	0.25
HA -4	0-6"	49.8	9.18
	1-1.5'	7.4	0.31
	3-3.5'	12.6	0.75
HA -5	0-6"	9.6	0.14
	1-1.5'	11.5	0.07
	3-3.5'	6.1	0.14
HA -6	0-6"	10.8	0.15
	1-1.5'	6.5	0.15
	3-3.5'	7.9	0.15
HA -7	0-6"	9.4	0.34
	1-1.5'	7.3	0.48
	3-3.5'	10.9	0.64
HA -8	0-6"	7.7	0.53
	1-1.5'	11.6	0.06
	3-3.5'	13.2	0.30
HA -9	0-6"	6.5	0.30
	1-1.5'	7.9	0.28
	3-3.5'	11.3	0.12
HA -10	0-6"	5.4	0.33
	1-1.5'	7.8	0.41
	3-3.5'	12.1	0.04
HA -11	0-6"	5.7	0.21
	1-1.5'	8.4	0.74
	3-3.5'	10.5	0.96
HA -12	0-6"	5.8	0.43
	1-1.5'	4.7	0.07
	3-3.5'	5.7	0.10
HA -13	0-6"	7.9	0.09
	1-1.5'	5.0	0.16
	3-3.5'	4.3	0.16
HA -14	0-6"	15.9	0.28
	1-1.5'	15.6	0.08
	3-3.5'	12.5	0.05
HA -15	0-6"	8.8	0.23
	1-1.5'	9.2	0.11
	3-3.5'	8.4	0.12

**Table 2 - DeBoer Moisture & Organic
Soil Testing Results**

LOCATION	DEPTH (ft.)	MOISTURE CONTENT %	ORGANIC CONTENT %
HA -16	0-6"	9.8	0.13
	1-1.5'	10.5	0.92
	3-3.5'	9.1	0.61
HA -17	0-6"	11.6	0.29
	1-1.5'	16.3	0.41
	3-3.5'	8.2	0.39
HA -18	0-6"	3.6	0.06
	1-1.5'	12.3	0.14
	3-3.5'	18.9	0.84
HA -19	0-6"	3.9	0.41
	1-1.5'	58.1	11.79
	3-3.5'	18.2	0.29
HA -20	0-6"	12.2	0.24
	1-1.5'	20.4	0.13
	3-3.5'	6.2	0.20
HA -21	0-6"	5.1	0.30
	1-1.5'	5.3	0.21
	3-3.5'	7.8	0.25
HA -22	0-6"	3.3	0.13
	1-1.5'	8.7	0.28
	3-3.5'	13.7	0.26
HA -23	0-6"	4.7	0.07
	1-1.5'	7.2	0.22
	3-3.5'	7.8	0.12
HA -24	0-6"	13.8	0.39
	1-1.5'	12.7	0.17
	3-3.5'	6.8	0.29
HA -25	0-6"	24.5	0.78
	1-1.5'	25.0	0.53
	3-3.5'	17.7	0.56
HA -26	0-6"	15.1	0.56
	1-1.5'	9.4	0.39
	3-3.5'	9.5	0.05
HA -27	0-6"	38.4	5.18
	1-1.5'	14.7	0.57
	3-3.5'	36.9	0.17
HA -28	0-6"	7.9	0.24
	1-1.5'	8.6	0.30
	3-3.5'	9.1	0.11
HA -29	0-6"	9.7	0.24
	1-1.5'	10.1	0.20
	3-3.5'	11.4	0.41
HA -30	0-6"	10.2	0.79
	1-1.5'	7.3	0.39
	3-3.5'	6.9	0.25

**Table 2 - DeBoer Moisture & Organic
Soil Testing Results**

LOCATION	DEPTH (ft.)	MOISTURE CONTENT %	ORGANIC CONTENT %
HA -31	0-6"	5.0	0.05
	1-1.5'	4.7	0.23
	3-3.5'	6.6	0.32
HA -32	0-6"	8.2	0.43
	1-1.5'	5.0	0.24
	3-3.5'	6.7	0.13
HA -33	0-6"	15.2	1.68
	1-1.5'	6.4	0.10
	3-3.5'	8.8	0.07
HA -34	0-6"	4.3	0.26
	1-1.5'	5.3	0.19
	3-3.5'	6.2	0.18
HA -35	0-6"	7.2	0.53
	1-1.5'	6.8	0.44
	3-3.5'	-18.7	0.44
HA -36	0-6"	7.0	0.12
	1-1.5'	10.4	0.10
	3-3.5'	18.2	0.08
HA -37	0-6"	12.3	0.68
	1-1.5'	7.0	0.09
	3-3.5'	3.1	0.05
HA -38	0-6"	5.0	0.29
	1-1.5'	6.0	0.10
	3-3.5'	3.3	0.19
HA -39	0-6"	4.6	0.10
	1-1.5'	6.1	0.17
	3-3.5'	8.0	0.09
HA -40	0-6"	7.0	0.21
	1-1.5'	7.1	0.72
	3-3.5'	7.6	0.13
HA -41	0-6"	6.4	0.27
	1-1.5'	6.3	0.07
	3-3.5'	3.2	0.06
HA -42	0-6"	9.6	0.17
	1-1.5'	12.5	0.20
	3-3.5'	7.7	0.37
HA -43	0-6"	8.5	0.17
	1-1.5'	6.3	0.29
	3-3.5'	5.2	0.27
HA -44	0-6"	7.6	0.11
	1-1.5'	7.6	0.23
	3-3.5'	7.7	0.25
HA -45	0-6"	4.5	0.15
	1-1.5'	6.3	0.14
	3-3.5'	9.1	0.04

**Table 2 - DeBoer Moisture & Organic
Soil Testing Results**

LOCATION	DEPTH (ft.)	MOISTURE CONTENT %	ORGANIC CONTENT %
HA -46	0-6"	6.5	0.21
	1-1.5'	8.0	0.08
	3-3.5'	8.7	0.20
HA -47	0-6"	13.6	0.83
	1-1.5'	20.4	0.51
	3-3.5'	6.3	0.29
HA -48	0-6"	7.4	0.19
	1-1.5'	6.1	0.14
	3-3.5'	16.3	0.06
HA -49	0-6"	3.0	0.09
	1-1.5'	4.3	0.19
	3-3.5'	4.7	0.17
HA -50	0-6"	7.2	0.28
	1-1.5'	12.5	0.15
	3-3.5'	10.2	0.24

APPENDIX D

Earthwork Specifications

**ALTA CALIFORNIA GEOTECHNICAL, INC.
EARTHWORK SPECIFICATIONS**

These specifications present the generally accepted standards and minimum earthwork requirements for the development of the project. These specifications shall be the project guidelines for earthwork except where specifically superceded in preliminary geology and soils reports, grading plan review reports or by the prevailing grading codes or ordinances of the controlling agency.

A. GENERAL

1. The Contractor shall be responsible for the satisfactory completion of all earthwork in accordance with the project plans and specifications.
2. The project Geotechnical Engineer and Engineering Geologist, or their representatives, shall provide observation and testing services, and Geotechnical consultation for the duration of the project.
3. All clearing, grubbing, stripping and site preparation for the project shall be accomplished by the Contractor to the satisfaction of the Geotechnical Engineer/Engineering Geologist.
4. It is the Contractor's responsibility to prepare the ground surface to receive fill to the satisfaction of the Geotechnical Engineer and to place, spread, mix, moisture condition, and compact the fill in accordance with the job specifications and as required by the Geotechnical Engineer. The Contractor shall also remove all material considered by the Geotechnical Engineer to be unsuitable for use in the construction of engineered fills.
5. The Contractor shall have suitable and sufficient equipment in operation to handle the amount of fill being placed. When necessary, equipment will be shut down temporarily in order to permit the proper preparation of fills.

B. PREPARATION OF FILL AREAS

1. Excessive vegetation and all deleterious material should be disposed of offsite as required by the Geotechnical Engineer.

Existing fill, soil, alluvium or rock materials determined by the Geotechnical Engineer as being unsuitable for placement in compacted fills shall be removed and hauled from the site. Where applicable, the Contractor may obtain the

approval of the Soils Engineer and the controlling authorities for the project to dispose of the above described materials, or a portion thereof, in designated areas onsite.

After removal of the deleterious materials have been accomplished, earth materials deemed unsuitable in their natural, in-place condition, shall be removed as recommended by the Geotechnical Engineer/Engineering Geologist.

2. Upon achieving a suitable bottom for fill placement, the exposed removal bottom shall be disced or bladed by the Contractor to the satisfaction of the Geotechnical Engineer. The prepared ground surfaces shall then be brought to the specified moisture content mixed as required, and compacted and tested as specified. In localities where it is necessary to obtain the approval of the controlling agency prior to placing fill, it will be the Contractor's responsibility to contact the proper authorities to visit the site.
3. Any underground structure such as cesspools, cisterns, mining shafts, tunnels, septic tanks, wells, pipelines or other structures not located prior to grading are to be removed or treated in a manner prescribed by the Geotechnical Engineer and/or the controlling agency for the project.

C. ENGINEERED FILLS

1. Any material imported or excavated on the property may be utilized as fill, provided the material has been determined to be suitable by the Geotechnical Engineer. Deleterious materials shall be removed from the fill as directed by the Geotechnical Engineer.
2. Rock or rock fragments less than twelve inches in the largest dimension may be utilized in the fill, provided they are not placed in concentrated pockets and the distribution of the rocks is approved by the Geotechnical Engineer.
3. Rocks greater than twelve inches in the largest dimension shall be taken offsite, or placed in accordance with the recommendations of the Geotechnical Engineer in areas designated as suitable for rock disposal.
4. All materials to be used as fill, shall be tested in the laboratory by the Geotechnical Engineer. Proposed import materials shall be approved by the Geotechnical Engineer 48 hours prior to importation.
5. The fill materials shall be placed by the Contractor in lifts, that when compacted, shall not exceed six inches. Each lift shall be spread evenly and shall be

thoroughly mixed to achieve a near uniform moisture condition and a uniform blend of materials.

All compaction shall be achieved at or above the optimum moisture content, as determined by the applicable laboratory standard. The Contractor will be notified if the fill materials are too wet or too dry to achieve the required compaction standard.

6. When the moisture content of the fill material is below the limit specified by the Geotechnical Engineer, water shall be added and the materials shall be blended until a uniform moisture content, within specified limits, is achieved. When the moisture content of the fill material is above the limits specified by the Geotechnical Engineer, the fill materials shall be aerated by discing, blading, mixed with dryer fill materials, or other satisfactory methods until the moisture content is within the specified limits.

7. Each fill lift shall be compacted to the minimum project standards, in compliance with the testing methods specified by the controlling governmental agency, and in accordance with recommendations of the Geotechnical Engineer.

In the absence of specific recommendations by the Geotechnical Engineer to the contrary, the compaction standard shall be the most recent version of ASTM:D 1557.

8. Where a slope receiving fill exceeds a ratio of five-horizontal to one-vertical, the fill shall be keyed and benched through all unsuitable materials into sound bedrock or firm material, in accordance with the recommendations and approval of the Geotechnical Engineer.
9. Side hill fills shall have a minimum key width of 15 feet into bedrock or firm materials, unless otherwise specified in the soil report and approved by the Geotechnical Engineer in the field.
10. Drainage terraces and subdrainage devices shall be constructed in compliance with the ordinances of the controlling governmental agency and/or with the recommendations of the Geotechnical Engineer and Engineering Geologist.
11. The Contractor shall be required to maintain the specified minimum relative compaction out to the finish slope face of fill slopes, buttresses, and stabilization fills as directed by the Geotechnical Engineer and/or the governing agency for the project. This may be achieved by either overbuilding the slope and cutting

back to the compacted core; by direct compaction of the slope face with suitable equipment; or by any other procedure which produces the required result.

12. The fill portion of fill-over-cut slopes shall be properly keyed into rock or firm material; and the fill area shall be stripped of all soil or unsuitable materials prior to placing fill.

The design cut portion of the slope should be made first and evaluated for suitability by the Engineering Geologist prior to placement of fill in the keyway above the cut slope.

13. Pad areas in cut or natural ground shall be approved by the Geotechnical Engineer. Finished surfaces of these pads may require scarification and recompaction, or over excavation as determined by the Geotechnical Engineer.

D. CUT SLOPES

1. The Engineering Geologist shall observe all cut slopes and shall be notified by the Contractor when cut slopes are to be started.
2. If, during the course of grading, unforeseen adverse or potentially adverse geologic conditions are encountered, the Engineering Geologist and Soil Engineer shall investigate, analyze and make recommendations to remediate these problems.
3. Non-erodible interceptor swales shall be placed at the top of cut slopes that face the same direction as the superjacent, prevailing drainage.
4. Unless otherwise specified in specific geotechnical reports, no cut slopes shall be excavated higher or steeper than that allowed by the ordinances of controlling governmental agencies.
5. Drainage terraces shall be constructed in compliance with the ordinances of the controlling governmental agencies, and/or in accordance with the recommendations of the Geotechnical Engineer or Engineering Geologist.

E. GRADING CONTROL

1. Fill placement shall be observed and tested by the Geotechnical Engineer and/or his representative during grading.

Field density tests shall be made by the Geotechnical Engineer and/or his representative to evaluate the compaction and moisture compliance of each fill lift. Density tests shall be conducted at intervals not to exceed two feet of fill

height. Where sheepfoot rollers are used, the fill may be disturbed to a depth of several inches. Density determinations shall be taken in the compacted material below the disturbed surface at a depth determined by the Geotechnical Engineer or his representative.

2. Where tests indicate that the density of any layer of fill, or portion thereof, is below the required relative compaction, or improper moisture content is in evidence, that particular layer or portion thereof shall be reworked until the required density and/or moisture content has been attained. Additional fills shall not be placed over an area until the previous lift of fill has been tested and found to meet the density and moisture requirements for the project and the previous lift is approved by the Geotechnical Engineer.
3. When grading activities are interrupted by heavy rains, fill operations shall not be resumed until field observations and tests by the Geotechnical Engineer indicate the moisture content and density of the fill are within the specified limits.
4. During construction, the Contractor shall properly grade all surfaces to maintain good drainage and prevent the ponding of water. The Contractor shall take remedial action to control surface water and to prevent erosion of graded areas until such time as a permanent drainage and erosion devices have been installed.
5. Observation and testing by the Geotechnical Engineer and/or his representative shall be conducted during filling and compacting operations in order that he will be able to state in his opinion that all cut and filled areas are graded in accordance with the approved specifications.
6. Upon the completion of grading activities and after the Geotechnical Engineer and Engineering Geologist have finished their observations of the work, final reports shall be submitted. No further excavation or fill placement shall be undertaken without prior notification of the Geotechnical Engineer and/or Engineering Geologist.

F. FINISHED SLOPES

All finished cut and fill slopes shall be planted and irrigated and/or protected from erosion in accordance with the project specifications, governing agencies, and/or as recommended by a landscape architect.

APPENDIX E

Grading Details

DETAIL FOR FILL SLOPE TOEING OUT ON FLAT ALLUVIATED CANYON

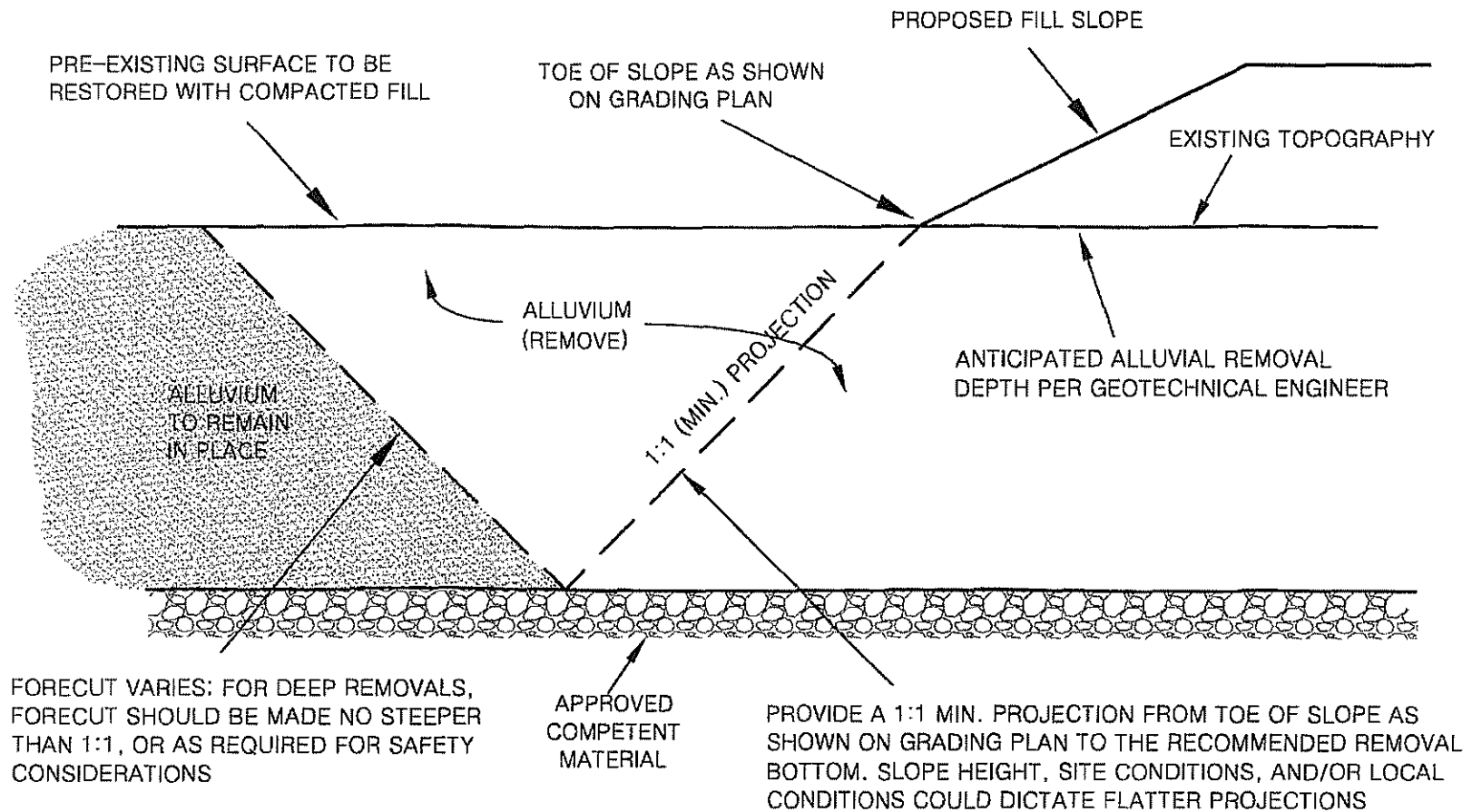

ALTA CALIFORNIA GEOTECHNICAL, INC.
VER. 3/12

PLATE G-1

REMOVAL ADJACENT TO EXISTING FILL

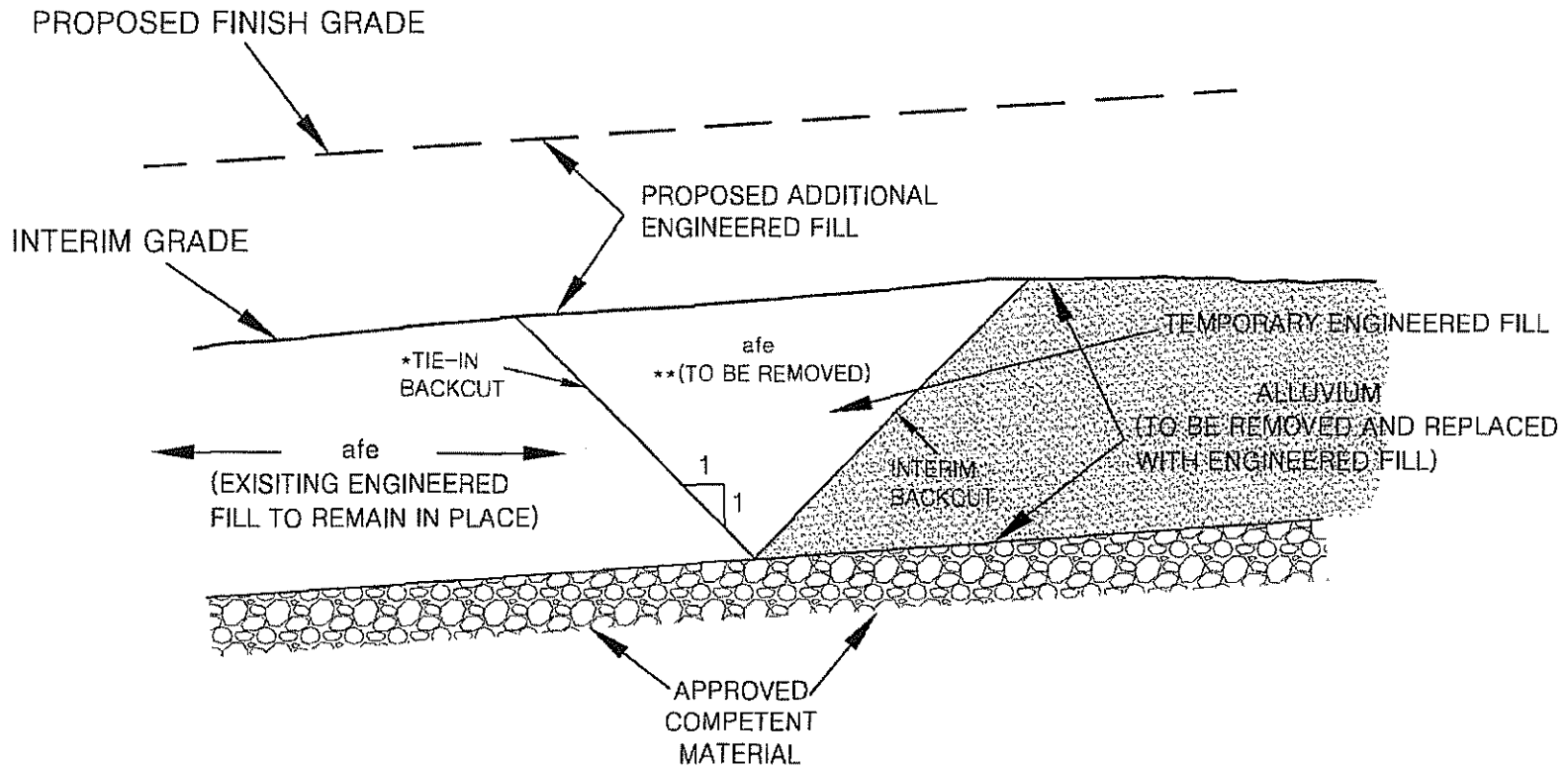

*INITIATE 1:1 TIE-IN BACKCUT TO INTERCEPT TOE OF INTERIM BACKCUT

**AS PART OF TIE-IN FOR ADDITIONAL ENGINEERED FILL



ALTA CALIFORNIA GEOTECHNICAL, INC .
VER. 3/12

PLATE G-2

CANYON SUBDRAIN

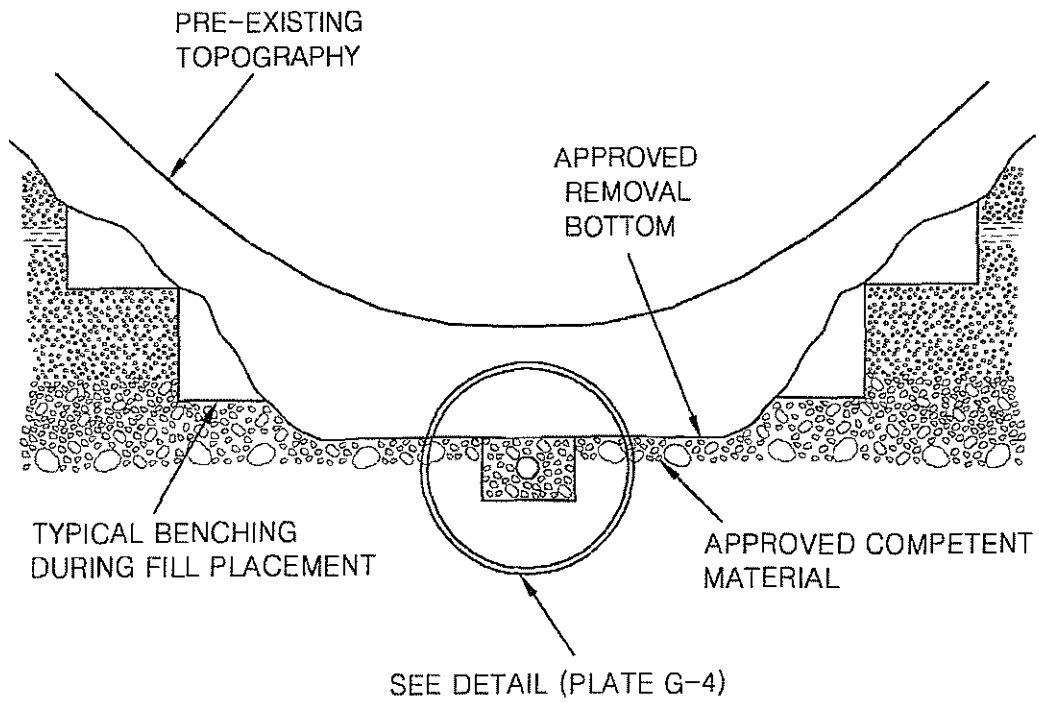

ALTA CALIFORNIA GEOTECHNICAL, INC .
VER. 3/12

PLATE G-3

CANYON SUBDRAIN DETAIL

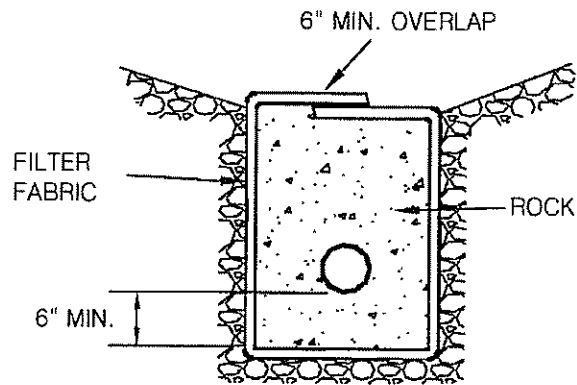

PERFORATED PIPE SURROUNDED WITH ROCK AND FILTER FABRIC

ROCK: MIN. VOLUME OF 9 CU.FT. PER LINEAR FT. OF 3/4 IN. MAX. ROCK

PIPE: 6 IN. ABS OR PVC PIPE WITH A MINIMUM OF 8 PERFORATIONS
(1/4-IN. DIA.) PER LINEAL FT. IN BOTTOM HALF OF PIPE
ASTM D2751, SDR 35, OR ASTM D3034 OR ASTM D1527,
SCHD. 40 ASTM D1785, SCHD. 40

FILTER FABRIC: MIRAFI 140 FILTER FABRIC OR APPROVED EQUIVALENT

NOTE: FOR CONTINUOUS RUN IN EXCESS OF 500. FT USE 8 IN. DIA. PIPE



ALTA CALIFORNIA GEOTECHNICAL, INC .
VER. 3/12

PLATE G-4

OVEREXCAVATION CUT LOT

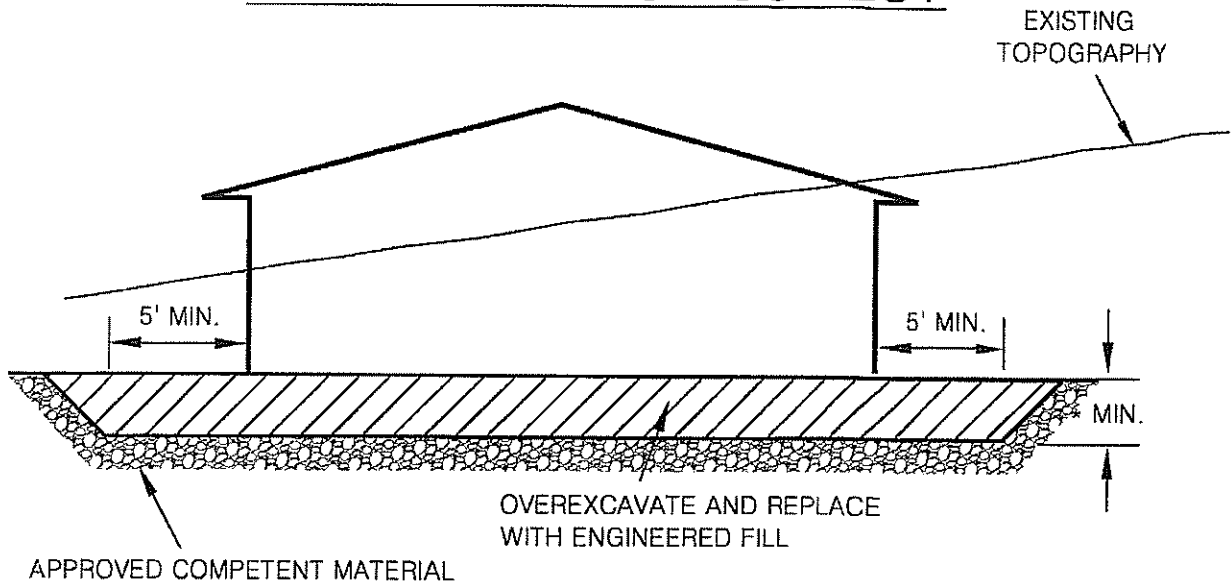

CUT-FILL LOT (TRANSITION)

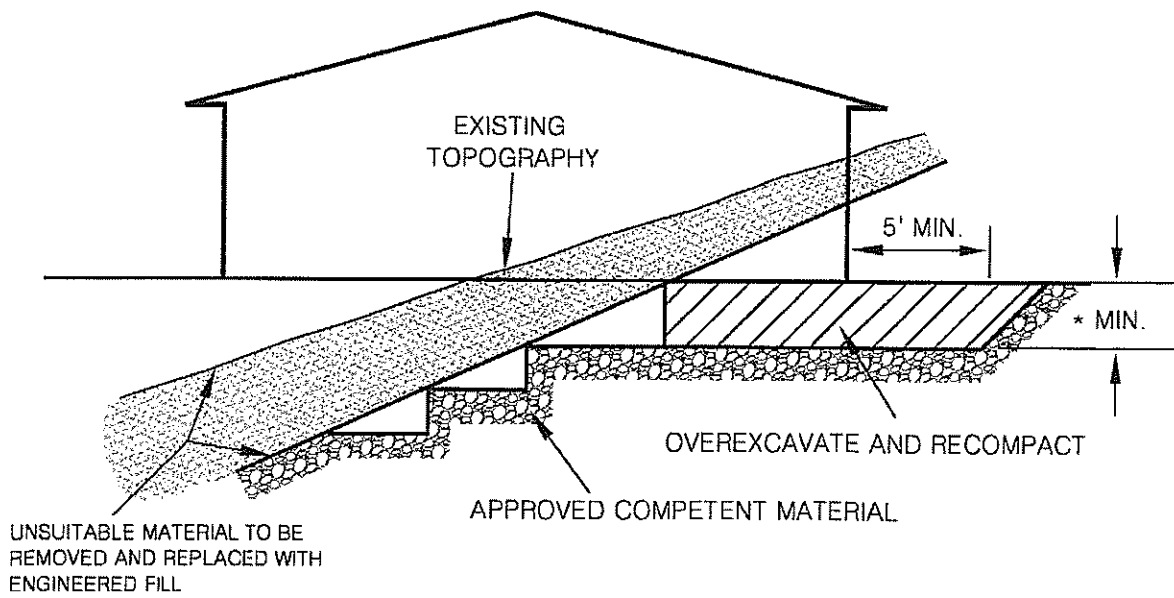

*NOTE ALL BUILDING PADS SHALL BE OVER EXCAVATED TO A MINIMUM OF $\frac{1}{3}$ OF THE MAXIMUM DEPTH OF FILL BELOW THE BUILDING PAD TO A MAXIMUM OF 17 FEET (SEE PLATE G-16)



ALTA CALIFORNIA GEOTECHNICAL, INC .
VER. 3/12

PLATE G-5

SIDE HILL SLOPE FILL DETAIL

(NATURAL SLOPES 5:1 OR STEEPER)

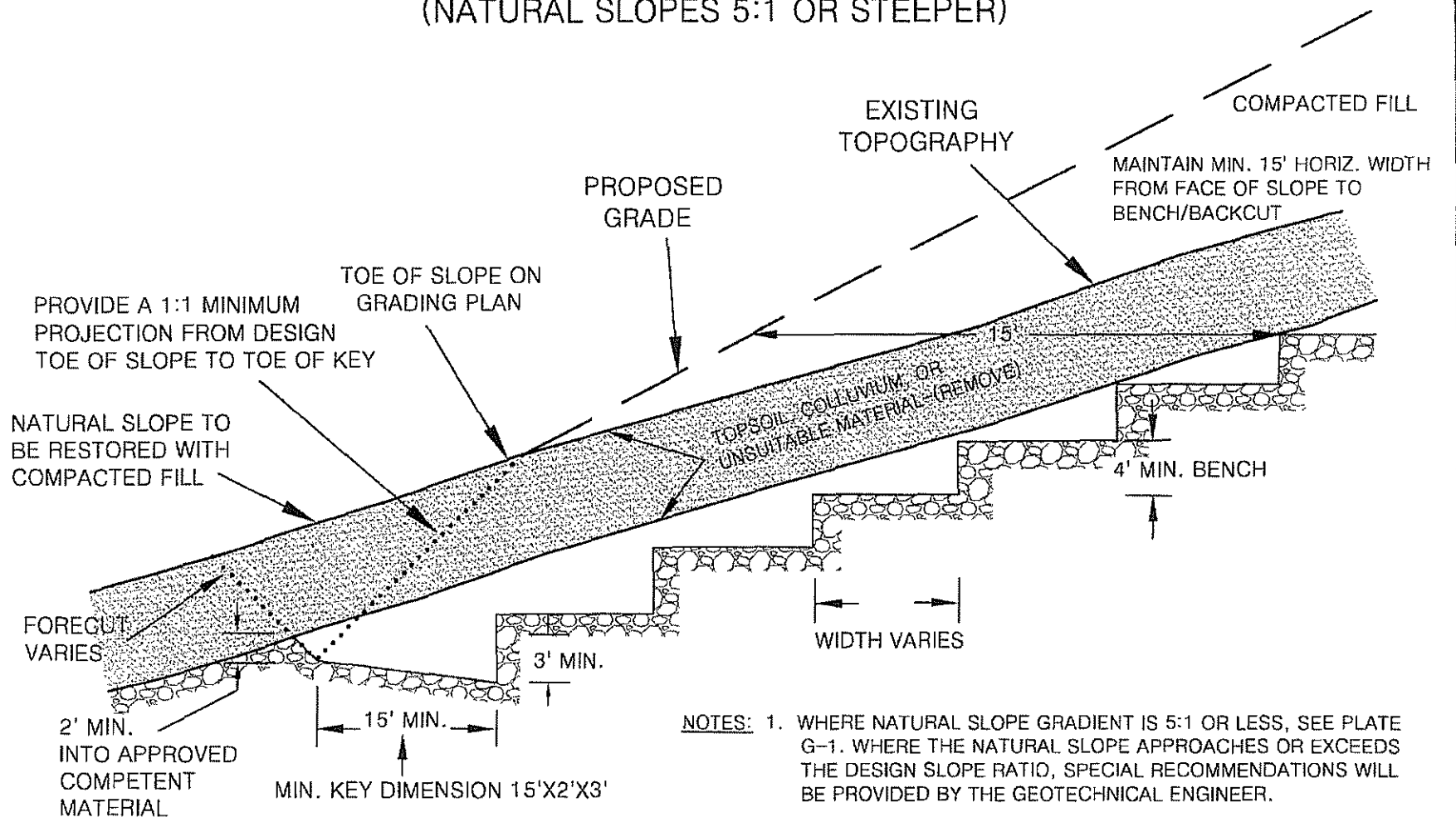

- NOTES:**
1. WHERE NATURAL SLOPE GRADIENT IS 5:1 OR LESS, SEE PLATE G-1. WHERE THE NATURAL SLOPE APPROACHES OR EXCEEDS THE DESIGN SLOPE RATIO, SPECIAL RECOMMENDATIONS WILL BE PROVIDED BY THE GEOTECHNICAL ENGINEER.
 2. THE NEED FOR AND PLACEMENT OF DRAINS WILL BE DETERMINED BY THE GEOTECHNICAL ENGINEER OR GEOLOGIST BASED UPON EXPOSED FIELD CONDITIONS.



ALTA CALIFORNIA GEOTECHNICAL, INC .
VER. 3/12

PLATE G-6

FILL OVER CUT SLOPE DETAIL

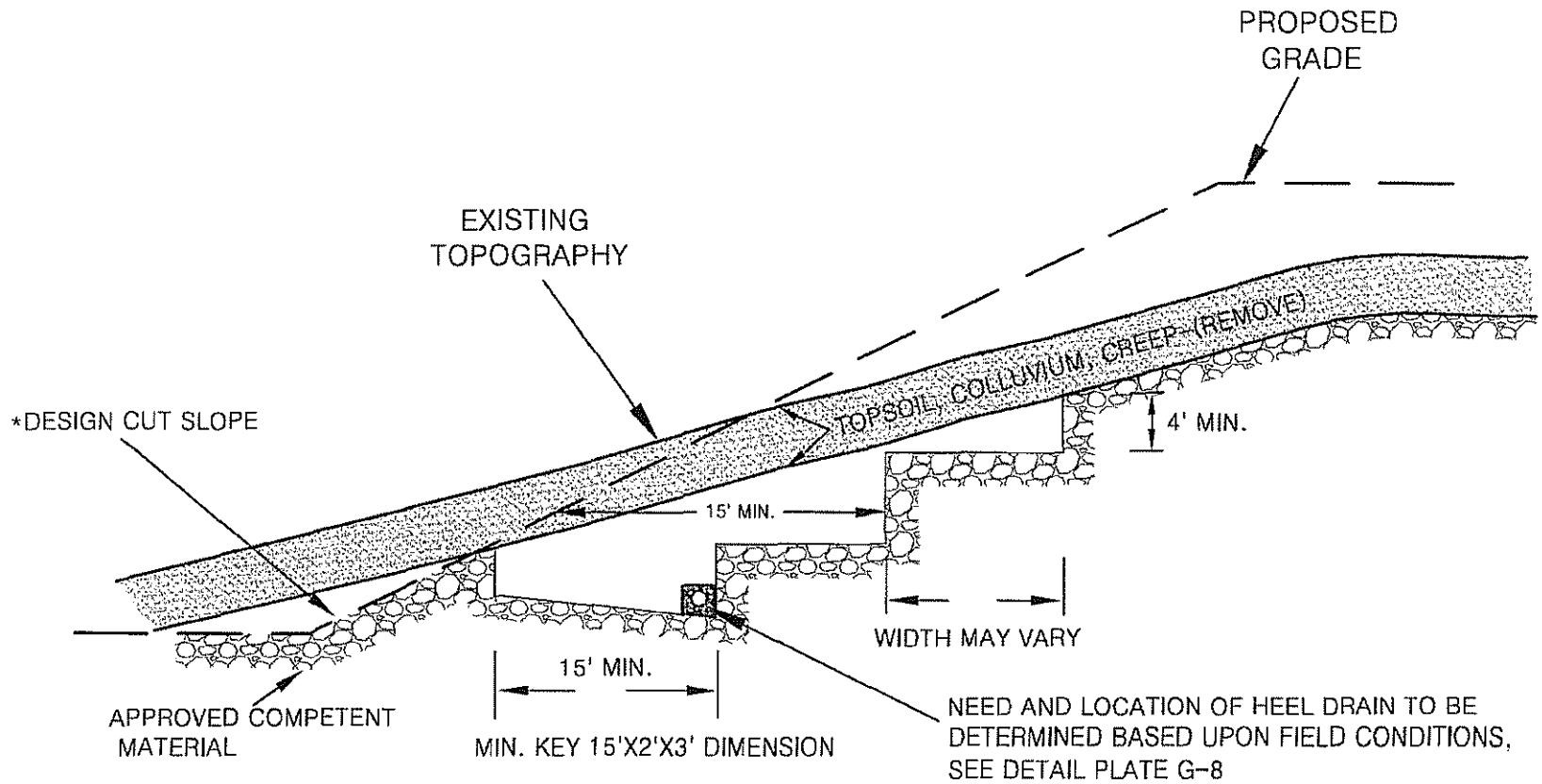

ALTA CALIFORNIA GEOTECHNICAL, INC .
VER. 3/12

PLATE G-7

STABILIZATION/BUTTRESS FILL BACKDRAIN

NOTE:

1. ASTM D2751, SDR 35, OR ASTM D3034 OR ASTM D1527, SCHD. 40 OR ASTM D1785, SCHD. 40
2. SOLID PIPE OUTLETS TO BE PROVIDED EVERY 100 FT. AND JOINED TO PERFORATED BACKDRAIN PIPE WITH "L" OR "T"s. MIN. 2% GRADIENT.
3. GRAVEL TRENCH TO BE FILLED WITH 3/4 IN. MAXIMUM ROCK
4. THE NECESSITY FOR UPPER TIER BACKDRAINS SHALL BE DETERMINED IN THE FIELD BY THE GEOTECHNICAL ENGINEER OR GEOLOGIST. UPPER TIER OUTLETS SHOULD DRAIN INTO PAVED TERRACE DRAINS.

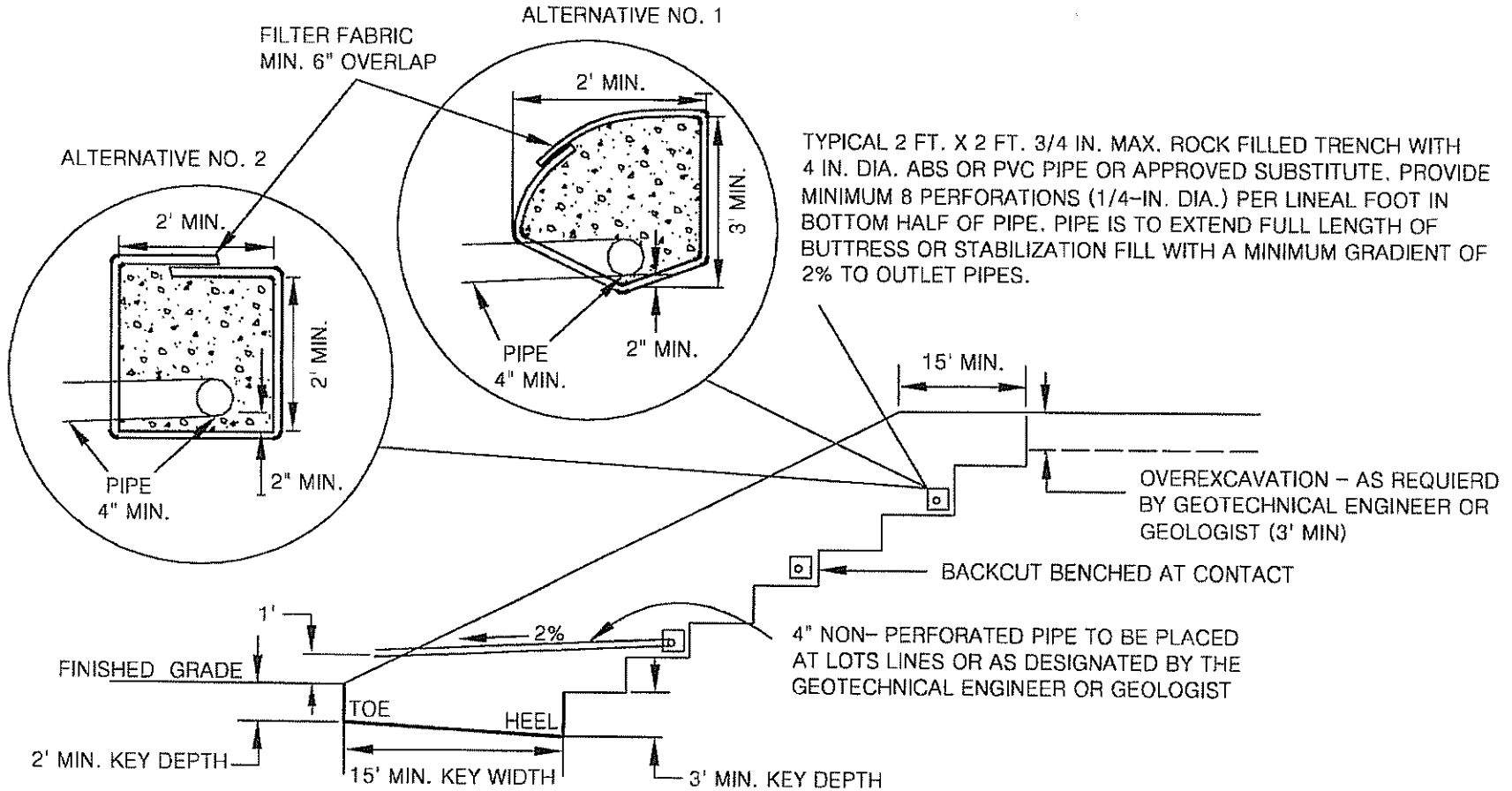

ALTA CALIFORNIA GEOTECHNICAL, INC.
VER. 3/12

PLATE G-8

STABILIZATION FILL (UPSLOPE ALLUVIATED AREA)

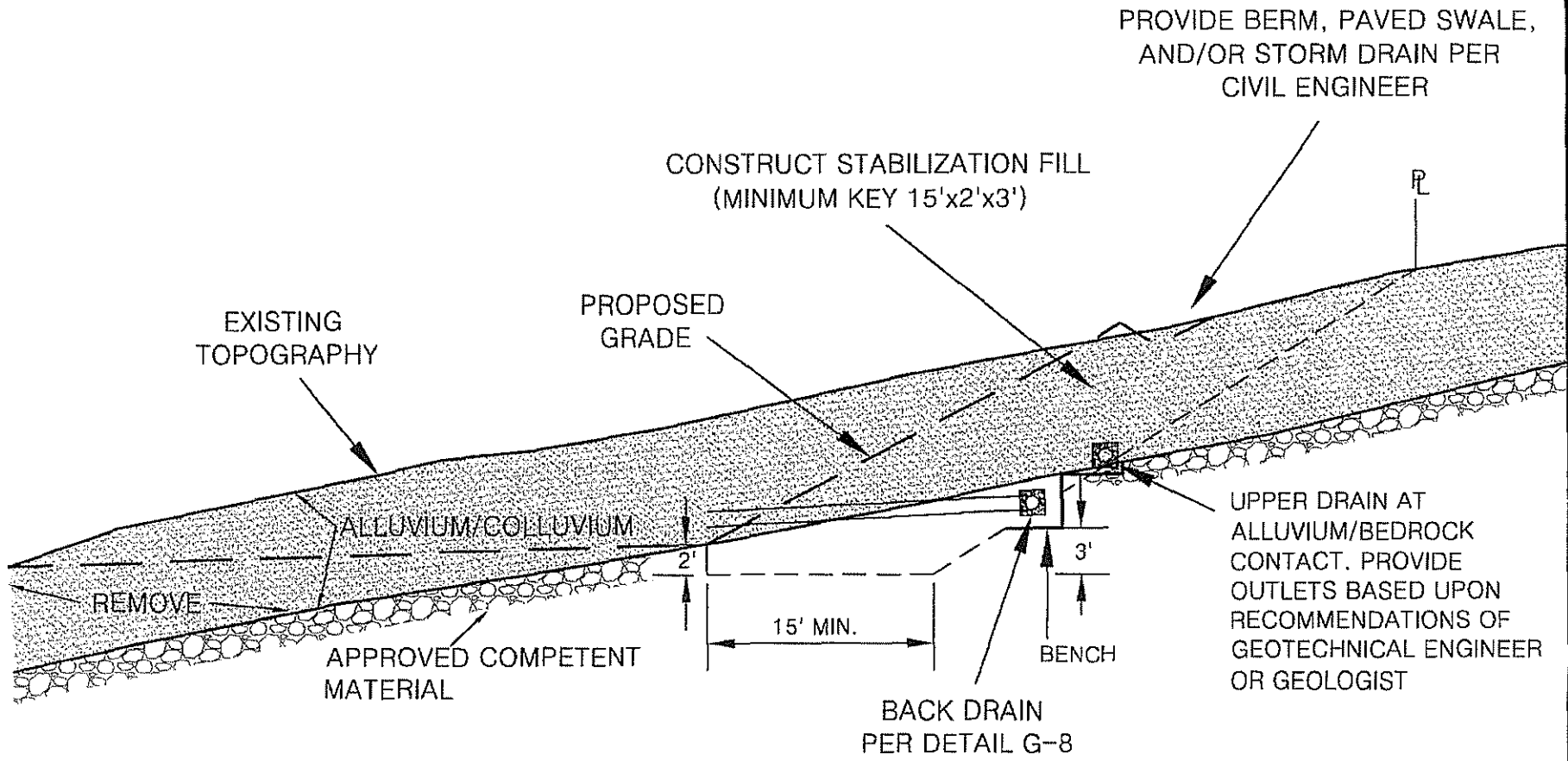

ALTA CALIFORNIA GEOTECHNICAL, INC .
VER. 3/12

PLATE G-9

SELECTIVE GRADING DETAIL FOR STABILIZATION FILL UNSTABLE MATERIAL EXPOSED IN PORTION OF CUT SLOPE

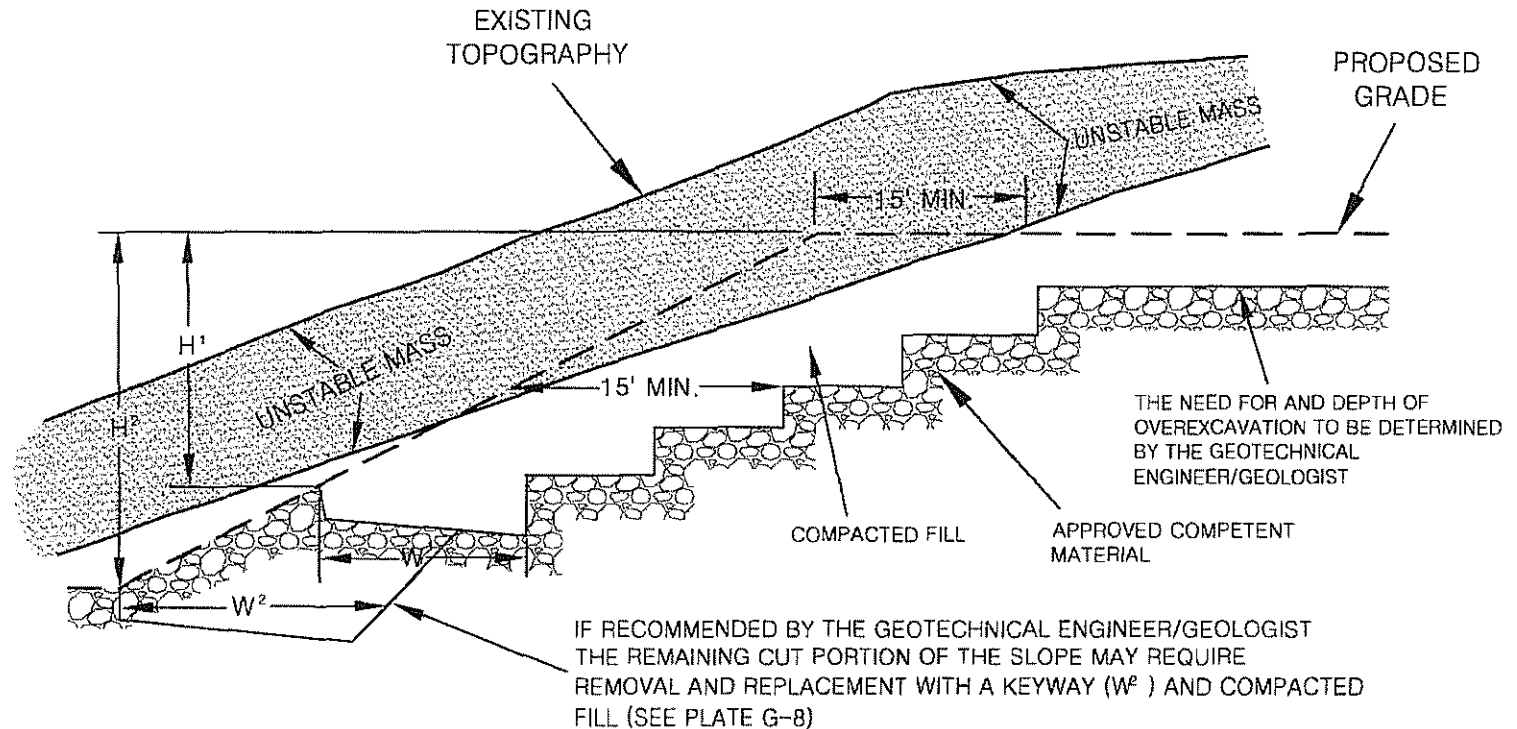

- NOTES:**
1. BACKDRAINS ARE NOT REQUIRED UNLESS SPECIFIED.
 2. "W" SHALL BE EQUIPMENT WIDTH (15') FOR SLOPE HEIGHT LESS THAN 25 FEET. FOR SLOPES GREATER THAN 25 FEET, "W" SHALL BE DETERMINED BY THE PROJECT GEOTECHNICAL ENGINEER/GEOLOGIST. AT NO TIME SHALL "W" BE LESS THAN H/2.



ALTA CALIFORNIA GEOTECHNICAL, INC .
VER. 3/12

PLATE G-10

SKIN FILL SLOPE OVER NATURAL GROUND

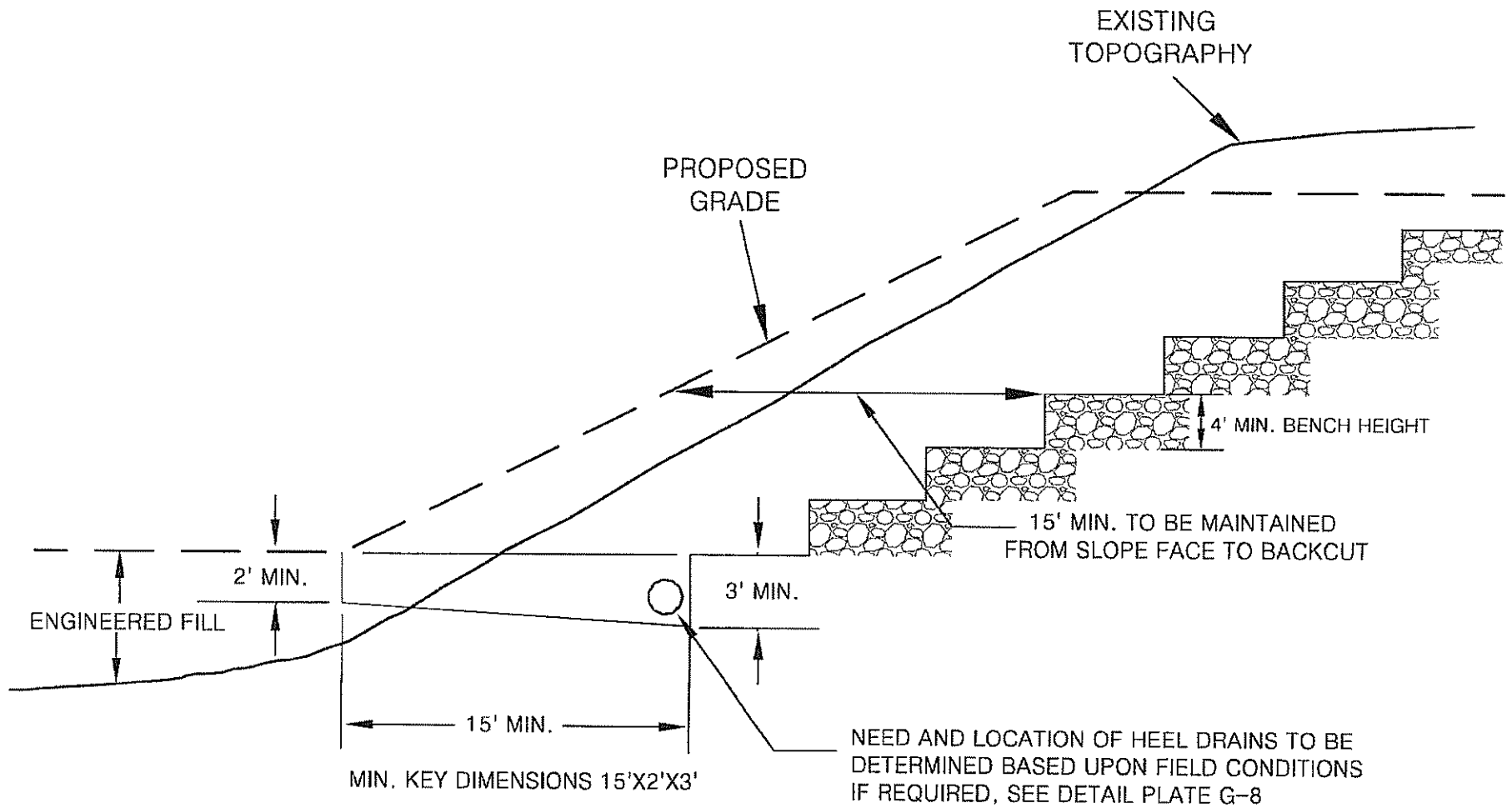

ALTA CALIFORNIA GEOTECHNICAL, INC.
VER. 3/12

PLATE G-11

DETAIL FOR MAXIMUM PARTICLE DIMENSION

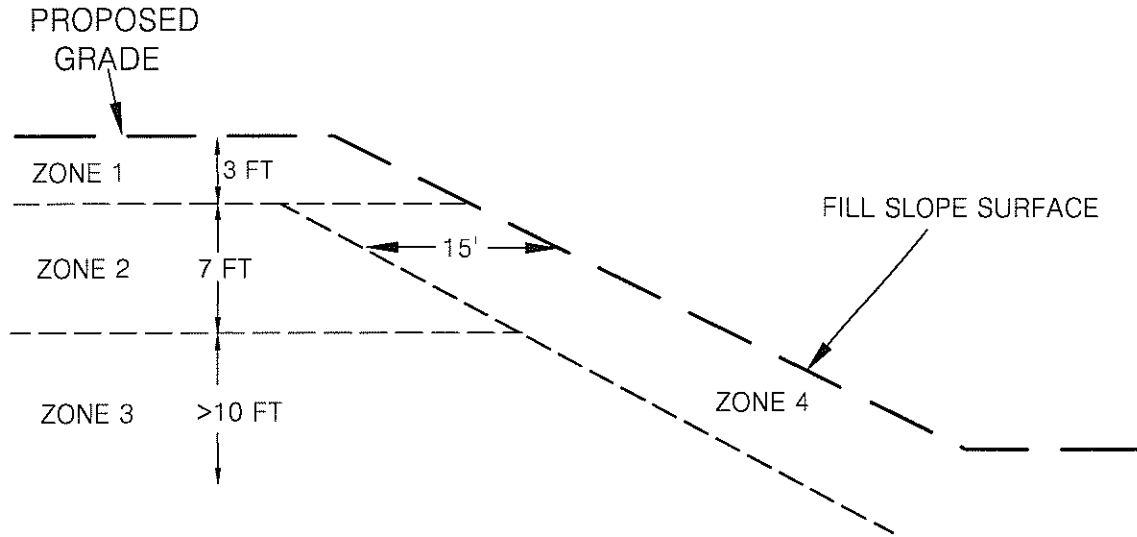

ZONE	DEPTH	PARTICLE MAX. DIMENSION	PLACEMENT METHOD
1	0-3 ft.	≤ 0.5 ft.	STANDARD OR CONVENTIONAL COMPACTION METHODS (SEE EARTHWORK SPECIFICATIONS)
2	3-10 ft.	≤ 2.0 ft.	ROCK BLANKETS (SEE PLATE G-13)
3	>10 ft.	≤ 8.0 ft.	ROCK BLANKETS (PLATE G-13) ROCK WINDROW (PLATE G-14) INDIVIDUAL ROCK BURIED (PLATE G-15)
4	15 HORIZONTAL FEET FROM FILL SLOPE FACE	≤ 1.0 ft.	STANDARD OR CONVENTIONAL COMPACTION METHODS (SEE EARTHWORK SPECIFICATIONS)



ALTA CALIFORNIA GEOTECHNICAL, INC.
VER. 2/15

PLATE G-12

ROCK BLANKET DETAILS

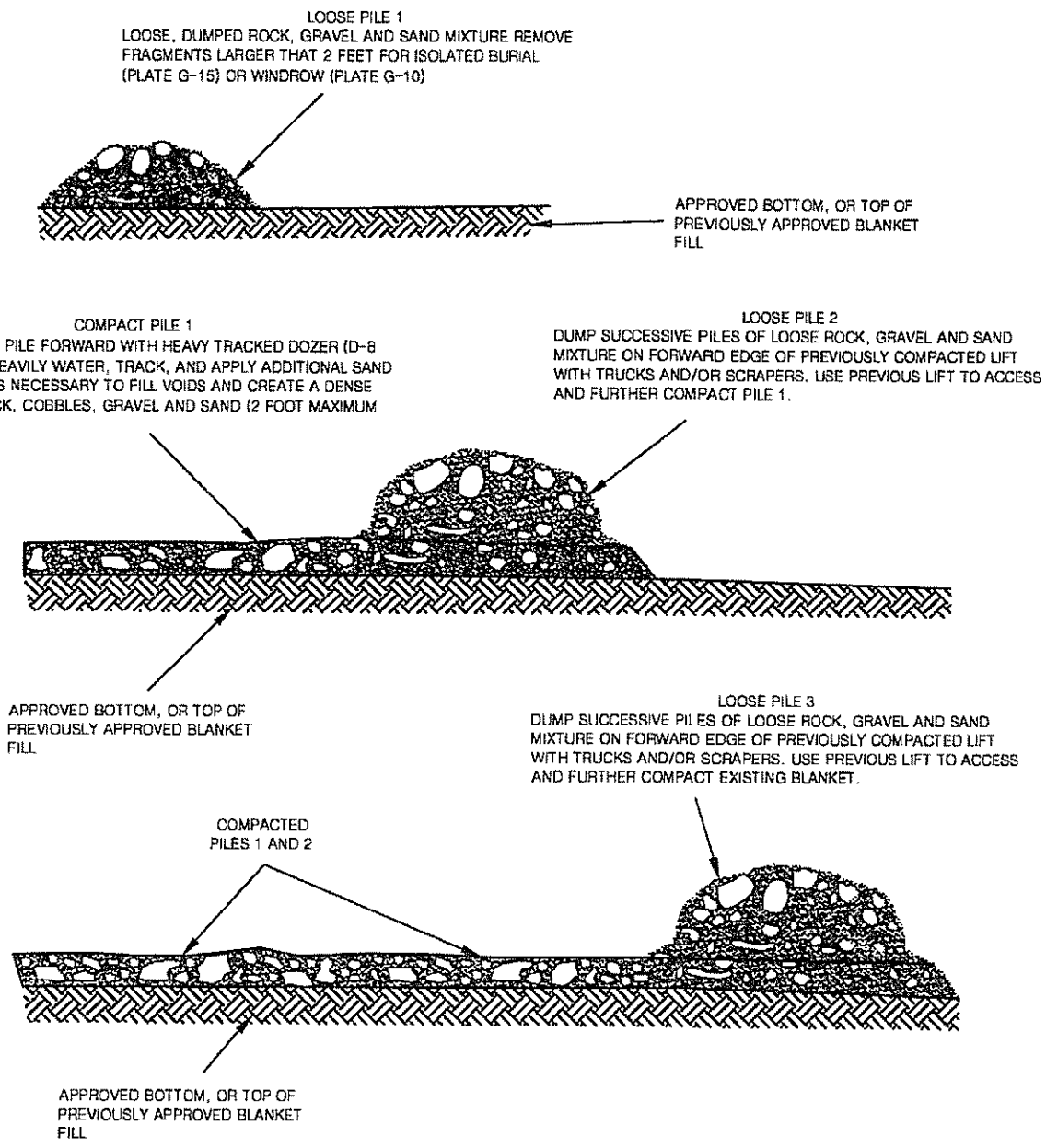

OBSERVATION TESTING AND APPROVAL PROCEDURES
OBSERVE EQUIPMENT. SCRAPERS AND TRUCKS SHOULD BE FULLY SUPPORTED ON BLANKET WITHOUT SIGNIFICANT YIELDING. EXCAVATE TEST/OBSERVATION PITS TO CONFIRM EXISTENCE OF MIXTURE OF VARIOUS PARTICLE SIZES, WITHOUT SIGNIFICANT VOIDS, AND FORMING A DENSE, COMPACTED FILL MATRIX. TEST BY ASTM D1556, D2922 AND/OR D3017 WHEN APPROPRIATE. RECORD LIMITS AND ELEVATION OF BLANKET. ALL FILL AND COMPACTION OPERATIONS TO BE CONDUCTED UNDER THE OBSERVATION OF THE GEOTECHNICAL ENGINEER. SUBSEQUENT LIFTS TO BE APPLIED ONLY AFTER OBSERVATION AND CONFIRMATION OF SUITABILITY OF FILL AND RELEASE BY THE GEOTECHNICAL ENGINEER. BLANKETS TO BE CONSTRUCTED IN ACCORDANCE WITH PLATE G-12.



ALTA CALIFORNIA GEOTECHNICAL, INC .
VER. 3/12

PLATE G-13

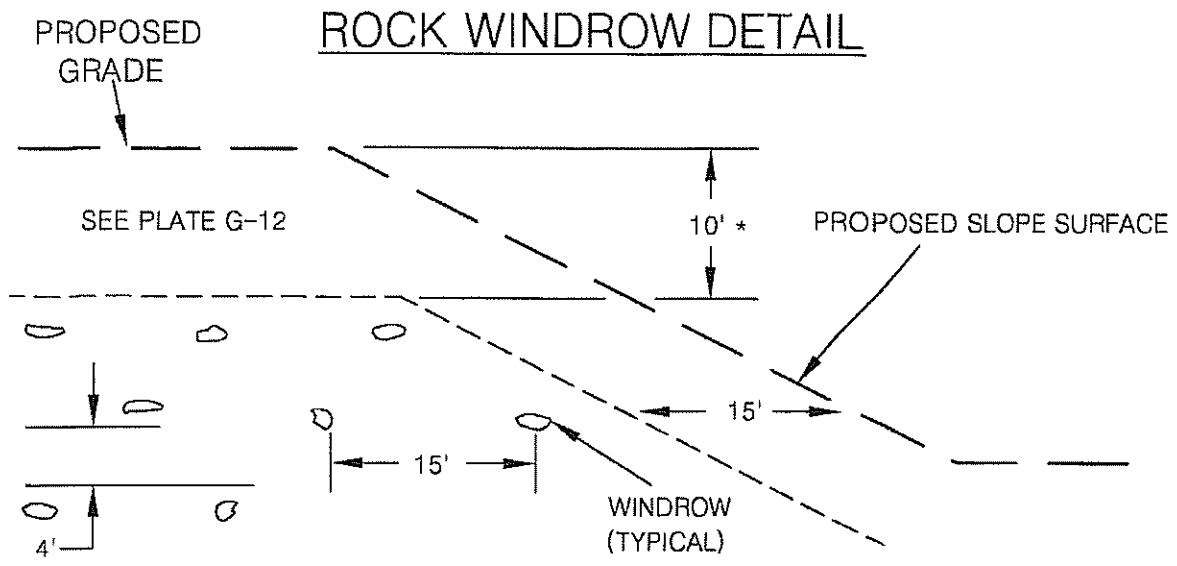

NOTE: OVERSIZED MATERIAL SHOULD BE REMOVED FROM THE 15' CLEAR ZONES WITH SPECIAL EQUIPMENT, SUCH AS A ROCK RAKE, PRIOR TO PLACING THE NEXT FILL LIFT.
 *VARIANCES TO THE ABOVE ROCK HOLD DOWN MAY BE GRANTED SUBJECT TO APPROVAL BY THE OWNER, GEOTECHNICAL ENGINEER, AND GOVERNING AGENCY

TYPICAL WINDROW DETAIL (END VIEW)

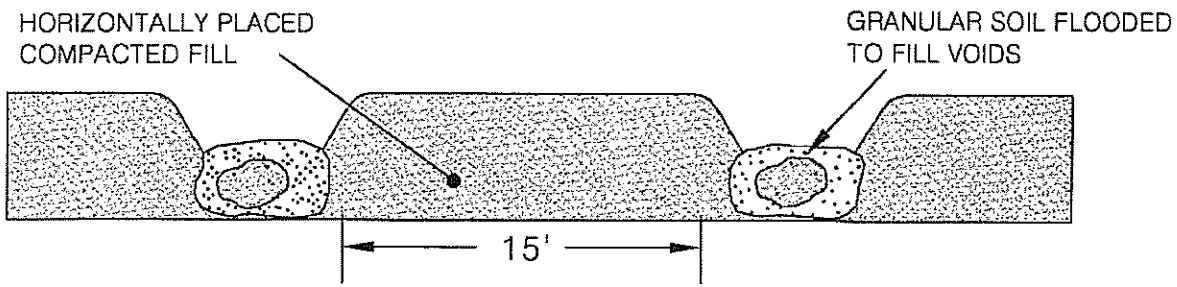

NOTE: COMPACTED FILL SHALL BE BROUGHT UP TO A HIGHER ELEVATION ALONG EACH WINDROW SO GRANULAR SOIL CAN BE FLOODED IN A "TRENCH CONDITION".

PROFILE VIEW

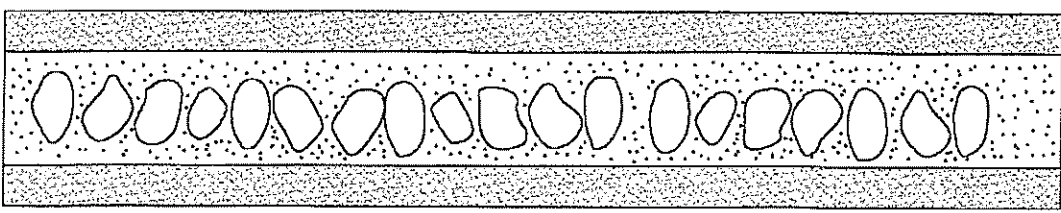

ALTA CALIFORNIA GEOTECHNICAL, INC.
 VER. 3/12

PLATE G-14

ISOLATED ROCK BURIAL DETAILS

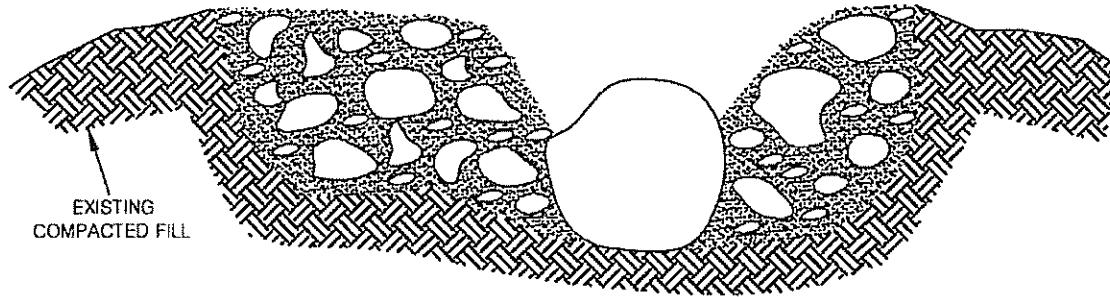

EXCAVATE HOLE INTO EXISTING FILL PRISM, PLACE BOULDER (< 8 feet in maximum dimension) INTO EXISTING COMPACTED FILL. SURROUND WITH SAND, GRAVEL, COBBLES AND WATER HEAVILY. TRACK WITH D8 OR LARGER EQUIPMENT UNTIL RESULTING FILL FULLY SUPPORTS EQUIPMENT. OBSERVE AND/OR TEST IN ACCORDANCE WITH ASTM D1556, D2922 OR D3017. ROCKS LARGER THAN 8 FEET SHALL BE FURTHER REDUCED IN SIZE BY SECONDARY BREAKING.

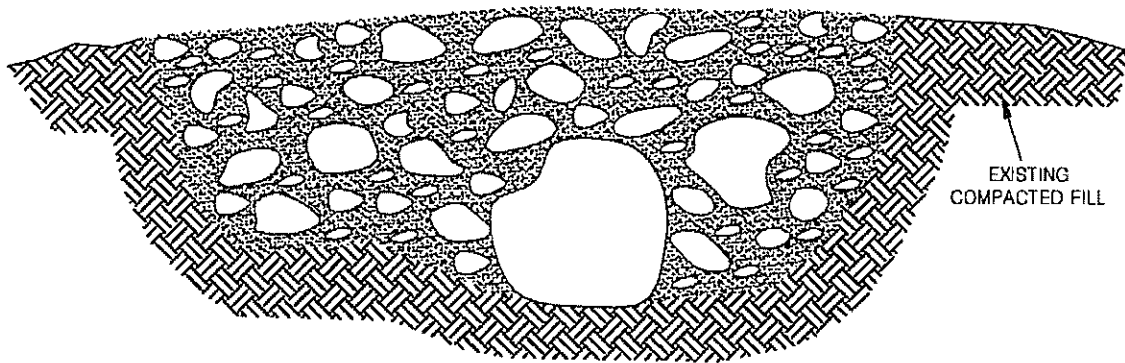

ALTA CALIFORNIA GEOTECHNICAL, INC .
VER. 3/12

PLATE G-15

RELATIVE COMPACTION VS. DEPTH

CANYON WALL LAY BACK DIFFERENTIAL FILL OVEREXCAVATION DETAILS

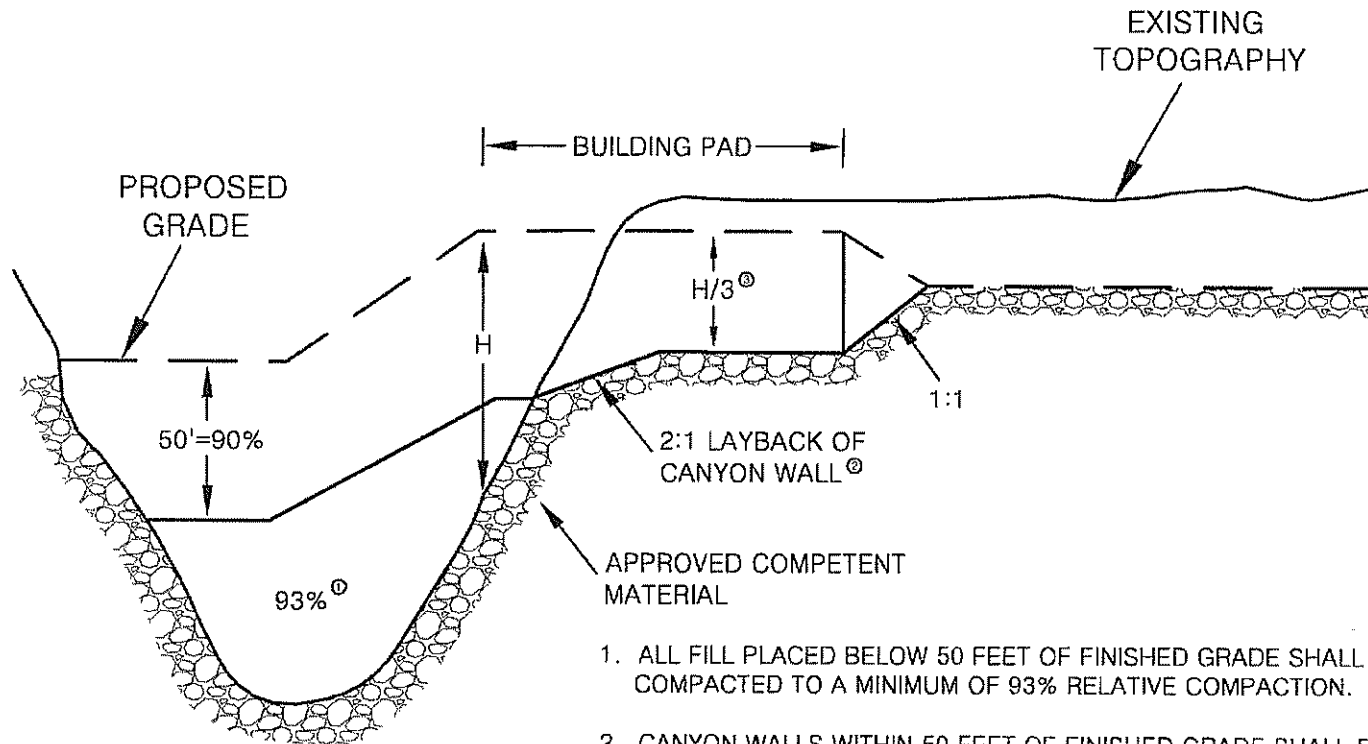

1. ALL FILL PLACED BELOW 50 FEET OF FINISHED GRADE SHALL BE COMPACTED TO A MINIMUM OF 93% RELATIVE COMPACTION.
2. CANYON WALLS WITHIN 50 FEET OF FINISHED GRADE SHALL BE LAID BACK TO A SLOPE RATIO OF 2:1 OR FLATTER.
3. ALL BUILDING PADS SHALL BE OVER EXCAVATED TO A MINIMUM OF 1/3 OF THE MAXIMUM DEPTH OF FILL BELOW THE BUILDING PAD TO A MAXIMUM OF 17 FEET.
4. IF THE 2:1 LAY BACK OF THE CANYON WALL IS IMPRACTICAL, THEN AS AN ALTERNATIVE THE INCREASED COMPACTION STANDARDS IN NOTE 1 SHOULD BE EXTENDED UP TO H/3 AND THE LAY BACK WILL NOT BE REQUIRED.



ALTA CALIFORNIA GEOTECHNICAL, INC .
VER. 3/12

PLATE G-16

SETTLEMENT PLATE DETAIL

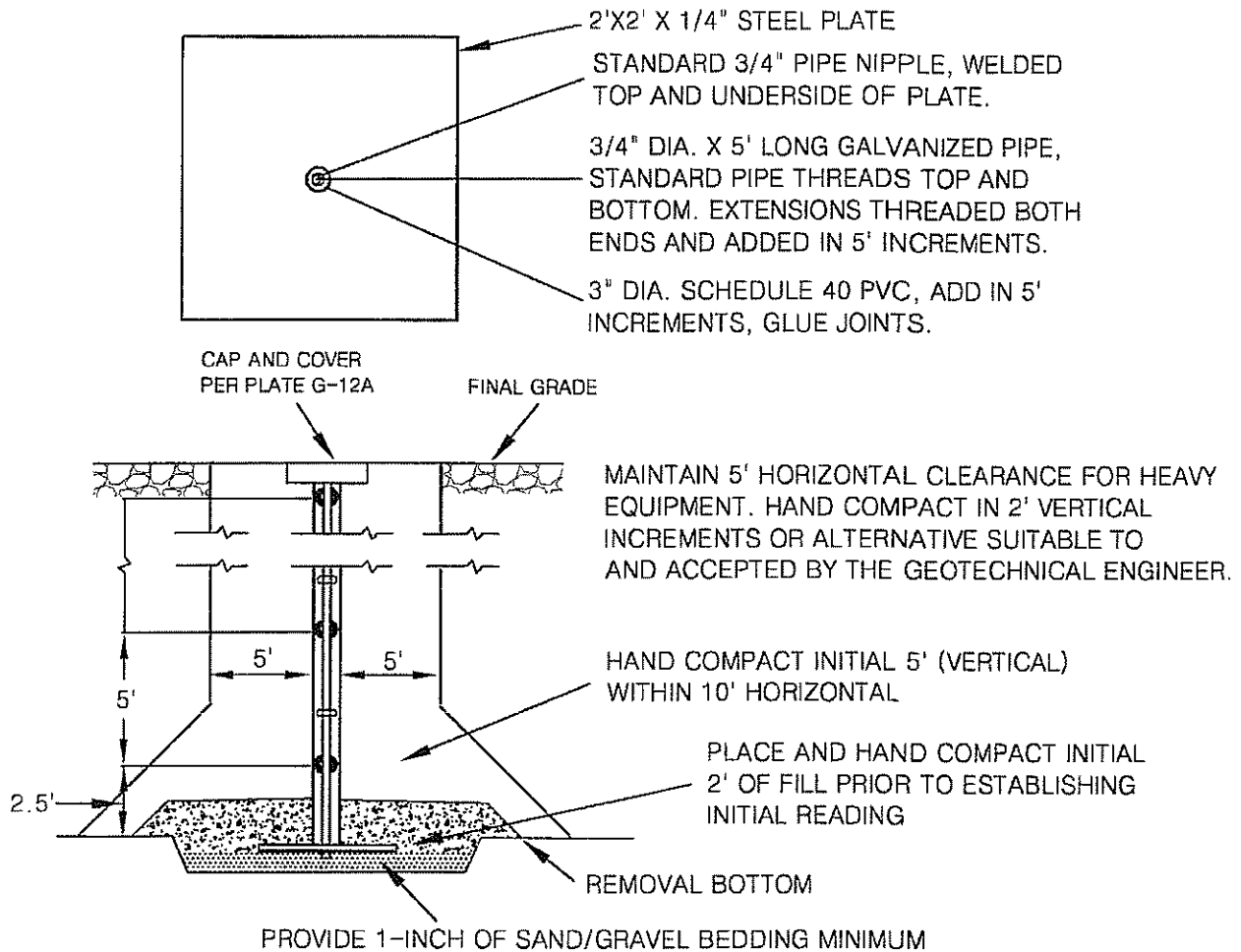

NOTES:

- 1) LOCATIONS OF SETTLEMENT PLATES SHALL BE CLEARLY MARKED AND READILY VISIBLE (RED FLAGGED) TO EQUIPMENT OPERATORS.
- 2) CONTRACTOR SHALL MAINTAIN 10' HORIZONTAL CLEARANCE FOR HEAVY EQUIPMENT WITHIN 5' (VERTICAL) OF PLATE BASE. FILL WITHIN CLEARANCE AREA SHALL BE HAND COMPACTED TO PROJECT SPECIFICATIONS OR COMPACTED BY ALTERNATIVE APPROVED BY THE GEOTECHNICAL ENGINEER.
- 3) AFTER 5' (VERTICAL) OF FILL IS IN PLACE, CONTRACTOR SHALL MAINTAIN 5' HORIZONTAL EQUIPMENT CLEARANCE. FILL IN CLEARANCE AREA SHALL BE HAND COMPACTED (OR APPROVED ALTERNATIVE) IN VERTICAL INCREMENTS NOT TO EXCEED 2 FEET.
- 4) IN THE EVENT OF DAMAGE TO SETTLEMENT PLATE OR EXTENSION RESULTING FROM EQUIPMENT OPERATING WITHIN PRESCRIBED CLEARANCE AREA, CONTRACTOR SHALL IMMEDIATELY NOTIFY GEOTECHNICAL ENGINEER AND SHALL BE RESPONSIBLE FOR RESTORING THE SETTLEMENT PLATE AND EXTENSION RODS TO WORKING ORDER.



ALTA CALIFORNIA GEOTECHNICAL, INC .
VER. 3/12

PLATE G-17

SURFACE SETTLEMENT MONUMENT DETAIL

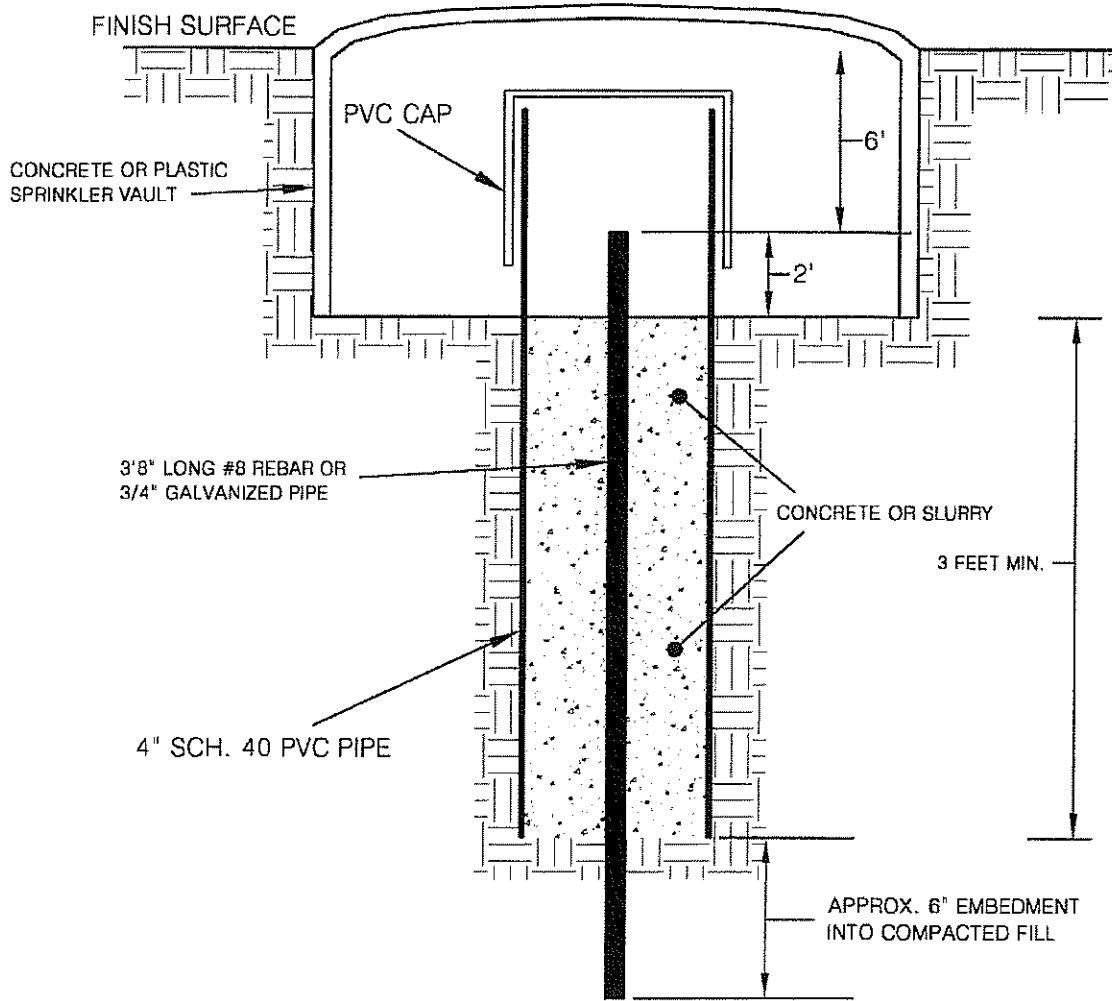

ALTA CALIFORNIA GEOTECHNICAL, INC .
VER. 3/12

PLATE G-18

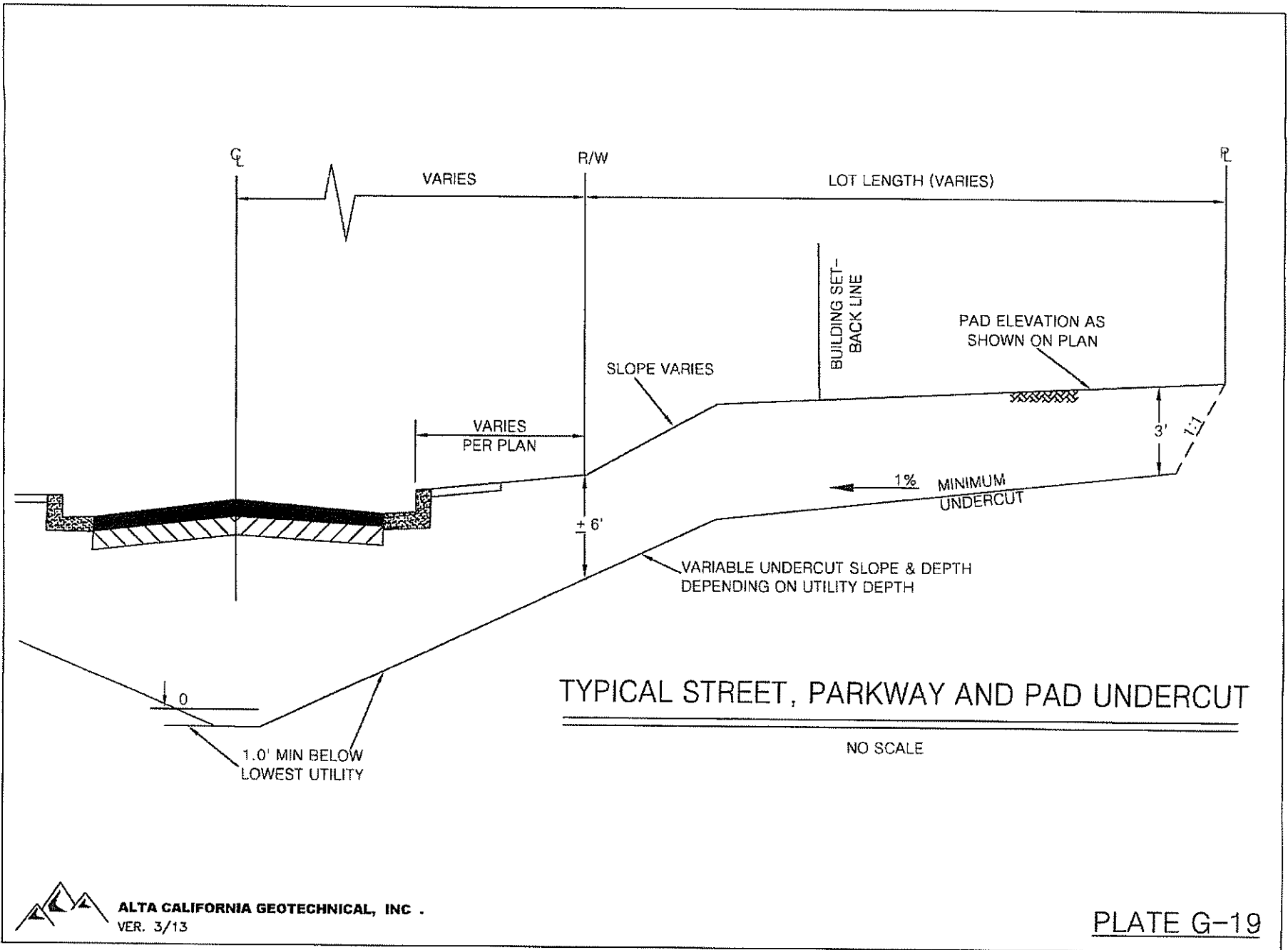

ALTA CALIFORNIA GEOTECHNICAL, INC.
 VER. 3/13

PLATE G-19



CV COMMUNITIES

3121 Michleson Drive, Suite 150
Irvine, California 92612

August 5, 2015

Project Number 1-0152

Attention: Mr. Adam Smith

Subject: **SUPPLEMENTAL TO PRELIMINARY GEOTECHNICAL INVESTIGATION**
Armstrong Ranch Specific Plan, DeBoer Parcels
City of Ontario, California

References:

1. Preliminary Geotechnical Investigation, Armstrong Ranch Specific Plan, DeBoer Parcels, City of Ontario, County of San Bernardino, California, by Alta California Geotechnical, Inc., dated April 14, 2015 (Project Number 1-0152).
2. 2013 Annual report of the Land Subsidence Committee, prepared for Chino Basin Watermaster, dated July 10, 2014, by Wildermuth Environmental, Inc.

Mr. Smith:

Presented herein is Alta California Geotechnical, Inc.'s (Alta's) supplemental to the referenced preliminary geotechnical investigation report for the Armstrong Ranch Specific Plan, in the City of Ontario, California. Specifically, this letter addresses the potential for subsidence onsite and provides the design peak ground acceleration.

Subsidence

There is a potential for subsidence within the Ontario area due to groundwater extraction from the Chino Basin. Per the Reference 2 report, subsidence throughout the area is relatively slow and uniform. As such, it is anticipated that if subsidence due to groundwater extraction were to occur, it would affect the entire region and not result in significant differential settlement across the site.

Peak Ground Acceleration

To determine site specific earthquake acceleration information, Alta performed a probabilistic seismic hazard analysis utilizing the USGS Interactive Deaggregation web site:

<https://geohazards.usgs.gov/deaggint/2008/>. The resultant peak ground acceleration was 0.703g, utilizing a 2% probability of exceedance in 50 years, per the 2013 CBC (See Plate 1 for result).

The opportunity to be of service is greatly appreciated. If you have any questions or should you require any additional information, please contact the undersigned at (858) 674-6636. Alta appreciates the opportunity to provide geotechnical consulting services for your project.

Sincerely,

Alta California Geotechnical, Inc.

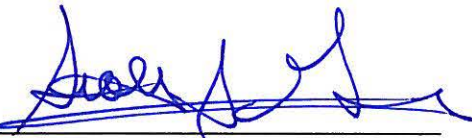
By: 

SCOTT A. GRAY/RGE 2857
Reg. Exp.: 12-31-16
Registered Geotechnical Engineer
Vice President



Distribution: (1) Addressee

SAG: 1-0152, August 5, 2015 (Supplemental to Geo Investigation, Armstrong Ranch)

PSH Deaggregation on NEHRP D soil
 Armstrong Ranch 117.606° W, 34.016 N.

Peak Horiz. Ground Accel. ≥ 0.7031 g
 Ann. Exceedance Rate .398E-03. Mean Return Time 2475 years
 Mean (R,M, ϵ_0) 17.1 km, 6.69, 1.66
 Modal (R,M, ϵ_0) = 14.3 km, 6.57, 2.04 (from peak R,M bin)
 Modal (R,M, ϵ^*) = 14.5 km, 6.56, > 2 sigma (from peak R,M, ϵ bin)
 Binning: DeltaR 10. km, deltaM=0.2, Delta ϵ =1.0

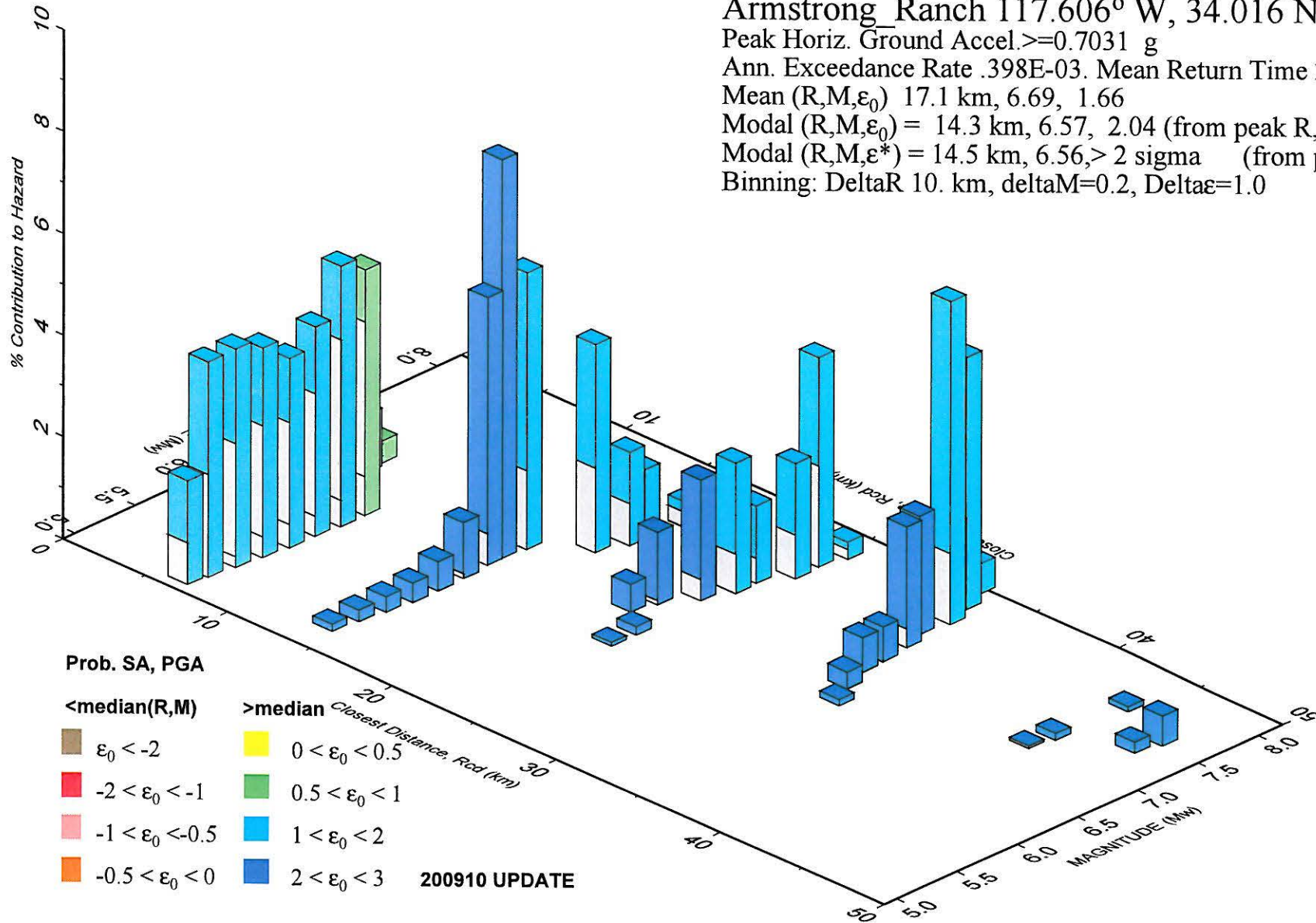

PLATE 1