

**TYP. UTILITY LAYOUT W/ STRIPED MEDIAN**  
(SECTION LOOKING NORTH AND WEST) NTS

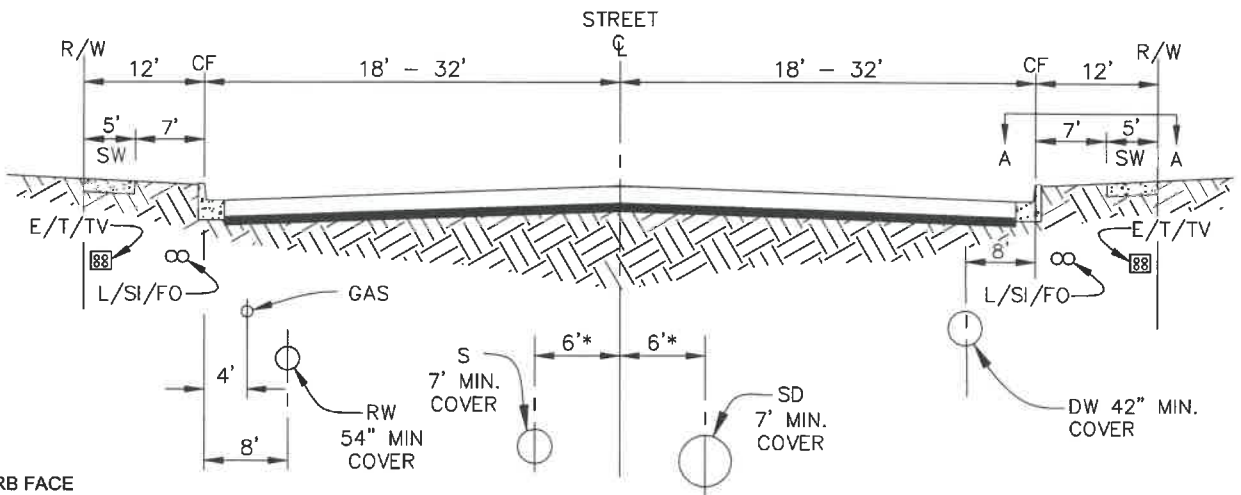

**TYP. UTILITY LAYOUT W/ NO MEDIAN**  
(SECTION LOOKING NORTH AND WEST) NTS

- CF = CURB FACE
- SW = SIDEWALK
- R/W = RIGHT OF WAY
- DW = DOMESTIC WATER
- G = GAS
- L = STREET LIGHTING
- RW = RECLAIMED WATER
- SD = STORM DRAIN
- S = SEWER
- T = TELEPHONE/FIBER OPTIC
- TV = CABLE TELEVISION
- E = ELECTRICAL
- SI = SIGNAL INTERCONNECT
- FO = CITY FIBER OPTIC W/  
PULL ROPE

\* FINAL LOCATION TO BE DETERMINED BASED ON LANE CONFIGURATION, MANHOLES AND VALVES TO BE PLACED OUTSIDE THE WHEEL LINE.

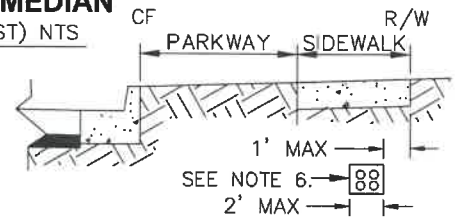

**JOINT UTILITY TRENCH SECTION A-A**

**NOTES**

1. PROVIDE 1' MIN. CLEARANCE AT UTILITY CROSSINGS
2. BETWEEN CURBS, COVER FOR LATERALS SHALL NOT BE LESS THAN 30" BELOW ROADWAY SURFACE.
3. MIN. SEPARATION BETWEEN WATER AND SEWER SHALL BE PER CITY STANDARD DRAWING NUMBER 4001.
4. VARIATIONS FROM STANDARD WILL REQUIRE PRIOR APPROVAL FROM CITY ENGINEER.
5. SEE STANDARD DRAWING 5014 FOR CURB RETURN AREA CLEAR ZONES.
6. A SINGLE, 2' WIDE MAXIMUM COMMON DRY UTILITY DUCT BANK (TO INCLUDE ELECTRIC, TELEPHONE, GAS AND FIBER OPTICS) WILL BE ALLOWED. MINIMUM COVER WILL BE 42" TO CROSS THE CLEAR ZONE PER CITY STANDARD DRAWING NUMBER 5203 AND SHALL NOT BE LOCATED MORE THAN 1-FOOT OFF THE RIGHT-OF-WAY LINE.
7. PROVIDE 4' MINIMUM WALL TO WALL CLEARANCE FOR ALL UTILITIES.
8. INSTALL (1) PULL ROPE WITHIN THE CITY FIBER OPTIC CONDUIT TO VERIFY CONTINUITY.



APPROVED BY:		62809 <i>5/5/21</i>	
<i>Khoi K. Do</i>		RCE	DATE
RECOMMENDED:		70990 <i>5/5/21</i>	
<i>Bryan Lirley</i>		RCE	DATE
REV	DESCRIPTION	BY	APP'D DATE

**CITY OF ONTARIO**

**UTILITY LOCATIONS FOR  
STANDARD STREET**

**STANDARD  
DRAWING  
NUMBER  
**1303****