

PLAN

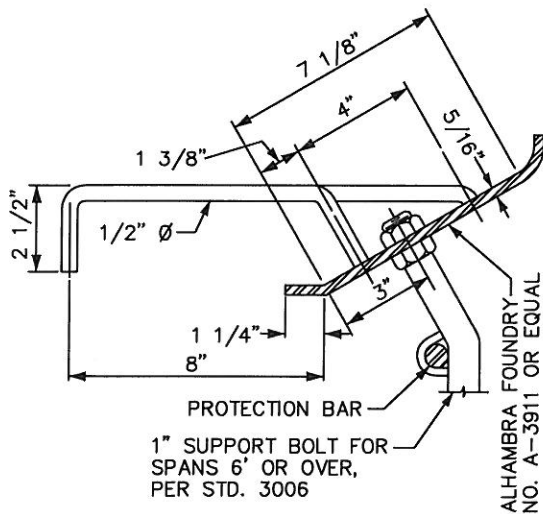

ANCHOR DERAIL

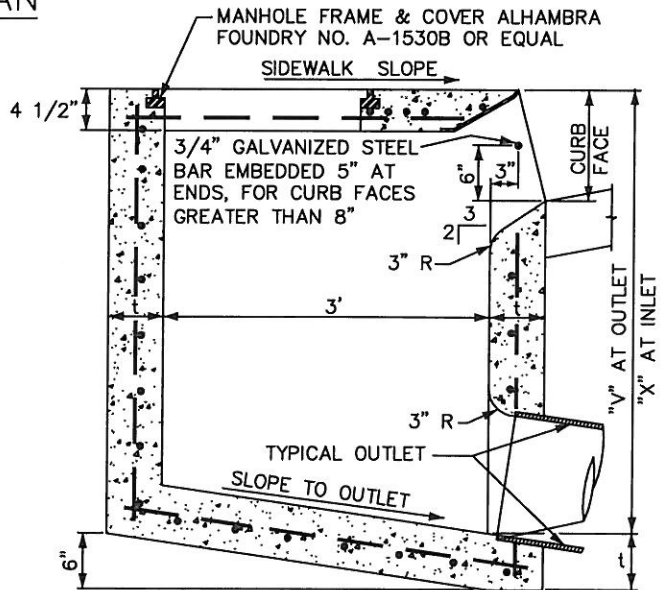

SECTION A-A

NOTES

1. ALL EXPOSED METAL PARTS SHALL BE GALVANIZED.
2. "V" = 3.5' UNLESS OTHERWISE SPECIFIED.
3. OUTLET PIPE MAY BE PLACED IN ANY POSITION AROUND WALLS.
4. CURB FACE AT C.B. OPENING SHALL BE THAT OF THE STANDARD CURB PLUS 4" OR AS OTHERWISE SHOWN.
5. CONCRETE SHALL BE CLASS 560-C-3250 PER SSPWC SECTION 201-1.
6. STEEL REINFORCEMENT AND WALL THICKNESS SHALL BE PER STANDARD DRAWING NO. 3004.
7. INSTALL POLYPROPYLENE PLASTIC STEP PER LATEST SPPWC STANDARD PLAN NO. 636.



APPROVED BY:				
<i>Louis Abi-Younes</i>		44485	4.14.15	
LOUIS ABI-YOUNES, PE, CITY ENGINEER		RCE	DATE	
RECOMMENDED:				
<i>Raymond Lee</i>		59059	4/13/15	
RAYMOND LEE, PE, ASST CITY ENGINEER		RCE	DATE	
REV	DESCRIPTION	BY	APP'D	DATE

CITY OF ONTARIO

CATCH BASIN NO. 2

STANDARD DRAWING NUMBER

3003