

MONUMENT TYPE "C"

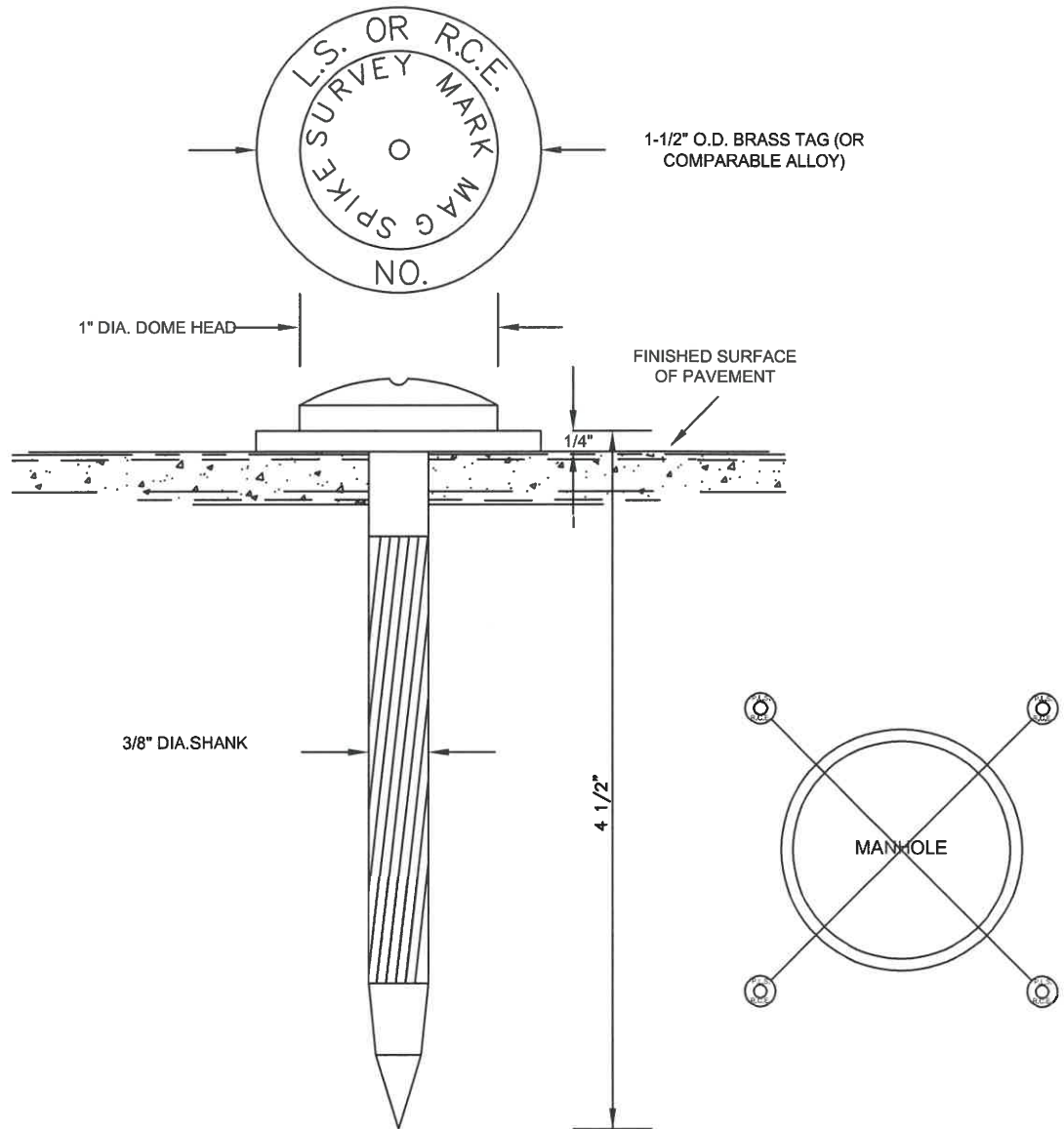

4-1/2" MAG SPIKE

NOTE

1. WHEN A CENTERLINE POINT LANDS ON OR NEAR A MANHOLE, 4 - MAG SPIKE (MINIMUM 4-1/2") AND WASHER CROSS-TIES ARE TO BE SET.
2. FOR CORNER RECORD MONUMENTATION PURPOSES: A 4-1/2" MINIMUM MAG SPIKE AND WASHER IS TO BE RESET ON COLLECTOR STREET CENTERLINES WHEN A EXISTING MONUMENT WILL BE DISTURBED OR BURIED 2" OR GREATER ON A NEWLY CONSTRUCTED ASPHALT STREET. UNLESS OTHER WISE DIRECTED BY THE CITY ENGINEER.
3. REFER TO STANDARD DRAWINGS 6106, 6107, AND 6111.



APPROVED BY:				
		62809	5/20/24	
KHOI DO, CITY ENGINEER		RCE	DATE	
RECOMMENDED:				
		70990	5/19/24	
BRYAN LURLEY, ASSISTANT CITY ENGINEER		RCE	DATE	
REV	DESCRIPTION	BY	APP'D	DATE

CITY OF ONTARIO

**MONUMENT
4-1/2" MAG SPIKE**

STANDARD
DRAWING
NUMBER

6104